

EUROPEAN PATENT OFFICE
U.S. PATENT AND TRADEMARK OFFICE

CPC NOTICE OF CHANGES 1008

DATE: JANUARY 1, 2021

PROJECT DP0219

The following classification changes will be effected by this Notice of Changes:

<u>Action</u>	<u>Subclass</u>	<u>Group(s)</u>
DEFINITIONS:		
Definitions New:	H04N	5/332, 5/341, 5/3415, 5/343, 5/345, 5/3452, 5/3454, 5/3456, 5/347, 5/349, 5/353, 5/3532, 5/3535, 5/3537, 5/355, 5/35509, 5/35518, 5/35527, 5/35536, 5/35545, 5/35554, 5/35563, 5/35572, 5/35581, 5/3559, 5/3572, 5/35721, 5/3575, 5/3577, 5/359, 5/3591, 5/3592, 5/3594, 5/3595, 5/3597, 5/3598, 5/363, 5/365, 5/3651, 5/3653, 5/3655, 5/3656, 5/3658, 5/367, 5/3675, 5/3696, 5/36961, 5/36963, 5/3698, 5/37213, 5/3741, 5/3742, 5/3745, 5/37452, 5/37455, 5/37457, 5/3765, 5/379
Definitions Modified:	H04N	5/30, 5/32, 5/33, 5/335, 5/351, 5/357, 5/361, 5/369, 5/36965, 5/374, 5/376, 5/378

No other subclasses/groups are impacted by this Notice of Changes.

This Notice of Changes includes the following [Check the ones included]:

1. CLASSIFICATION SCHEME CHANGES

- A. New, Modified or Deleted Group(s)
- B. New, Modified or Deleted Warning(s)
- C. New, Modified or Deleted Note(s)
- D. New, Modified or Deleted Guidance Heading(s)

2. DEFINITIONS

- A. New or Modified Definitions (Full definition template)
- B. Modified or Deleted Definitions (Definitions Quick Fix)

3. REVISION CONCORDANCE LIST (RCL)

4. CHANGES TO THE CPC-TO-IPC CONCORDANCE LIST (CICL)

5. CHANGES TO THE CROSS-REFERENCE LIST (CRL)

2. A. DEFINITIONS (new)

Insert: The following new Definitions.

H04N 5/332

Definition statement

This place covers:

visible light sensors without IR filter, i.e. a pixel captures both visible and IR light (Y+IR);

visible light sensors with switchable IR filter, i.e. the pixels are controlled to capture either only the visible light (Y) or both visible and IR light (Y+IR);

arrangements of multiple image sensors at least one of which is sensitive to IR light.

References

Limiting references

This place does not cover:

Picture signal generators using solid-state devices with colour filter architecture including elements transmitting or passing infrared wavelengths	H04N 9/04553
---	------------------------------

Informative references

Attention is drawn to the following places, which may be of interest for search:

Investigating the spectrum	G01J 3/28
Imaging spectrometer	G01J 3/2823

Special rules of classification

Image sensors comprising visible light and IR light sensitive pixels and image sensors comprising pixels both visible and IR light (Y+IR) and IR light sensitive pixels (IR) are classified in [H04N 9/04553](#).

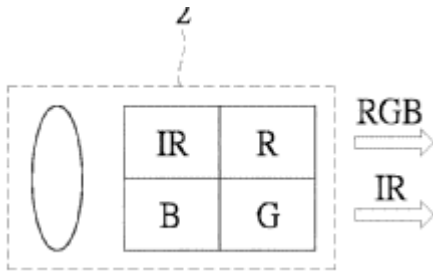

H04N 5/341

Definition statement

This place covers:

details of extracting pixel data from an image sensor by controlling scanning circuits.

The parent group [H04N 5/341](#) shall be assigned for scanning details not classified in child groups, for example:

- scanning different regions of an image sensor with variable frame rate, i.e. the regions of the image have different frame rates; the regions can be predetermined or dynamic selection;

FIG. 7

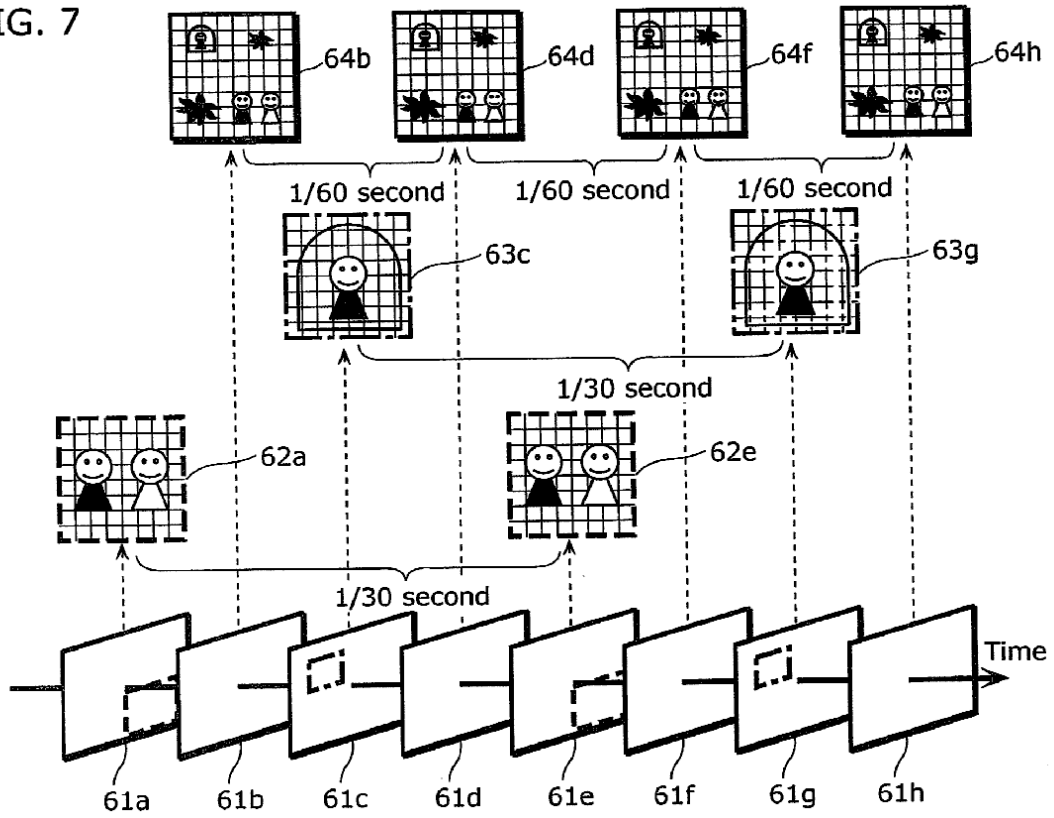

- non-destructive readout scanning of pixels during the integration period of the pixel;

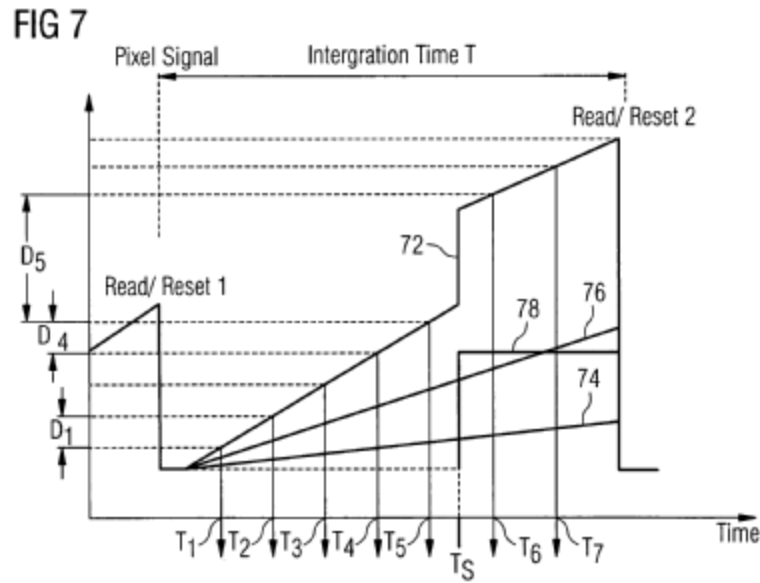

- scanning individual pixels or pixel regions;

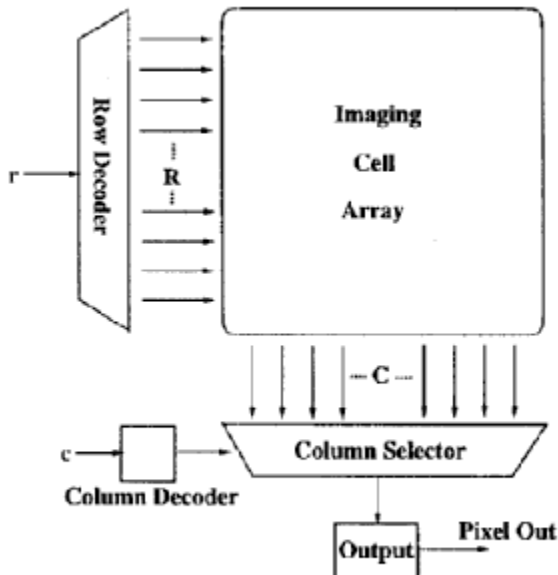
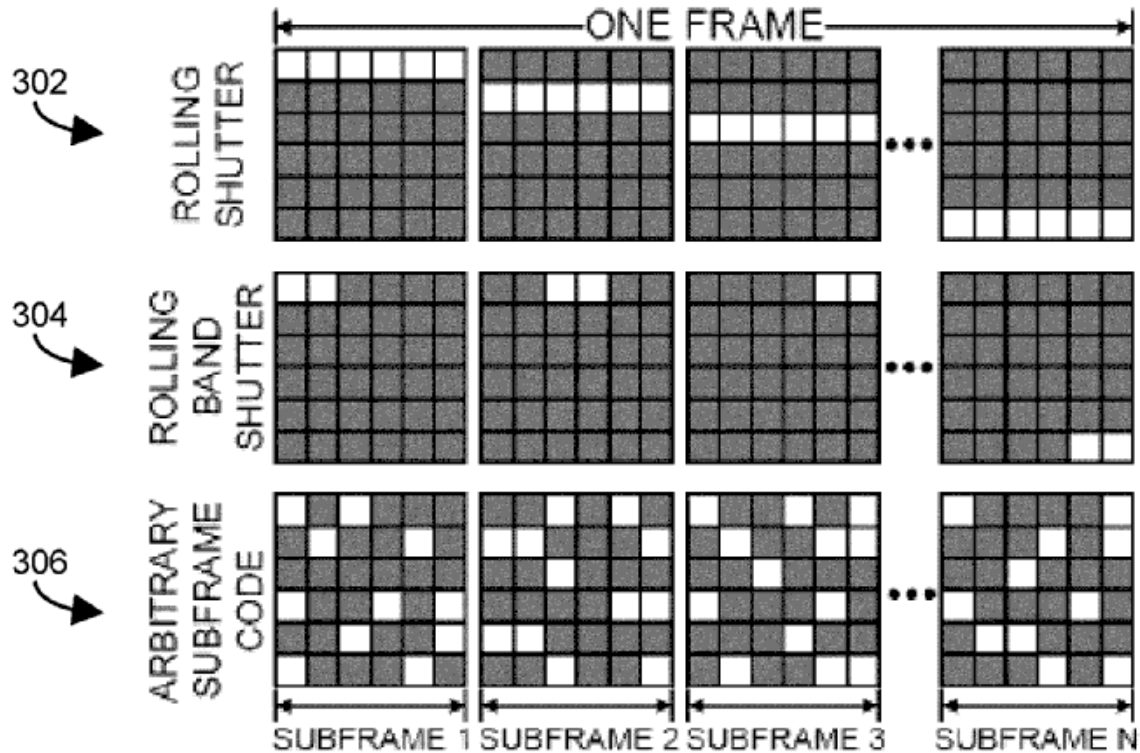

Figure 1: Random Access PD-array

- special scanning, like scanning in blocks, pyramidal;



- scanning and reading out data from a pixel while the pixel accumulates new charges or scanning or reading out data from a block, while the block processes the next data. Normally additional storage elements like double buffers or parallel processing circuits are used, e.g., reading a pixel while the next exposure is running, reading out digital ADC data while the ADC is running the next conversion cycle, etc.;
- scanning and reading out data from focussing pixels alone or in combination with imaging pixels;
- image sensor for high-speed operations where number of frames are successively captured and stored in the sensor and then read out from the memories.

DATE: JANUARY 1, 2021

PROJECT DP0219

References

Informative references

Attention is drawn to the following places, which may be of interest for search:

Addressing circuits	H04N 5/376
---------------------	----------------------------

Special rules of classification

The group [H04N 5/376](#) (Addressing circuits) shall be assigned in combination with [H04N 5/341](#) only if specific details of the scanning circuits are provided.

The readout operations in most of the cases influence the exposure time of the pixels. In such cases [H04N 5/353](#) should be added only if details related to the control of the exposure time are disclosed.

H04N 5/3415

Definition statement

This place covers:

arrangements and scanning details of image sensing units comprising plurality of image sensor arrays or panels, for example:

- compound image sensing units arranged to direct light from a different section of the field of view onto different image sensors or different image sensor regions;

DATE: JANUARY 1, 2021

PROJECT DP0219

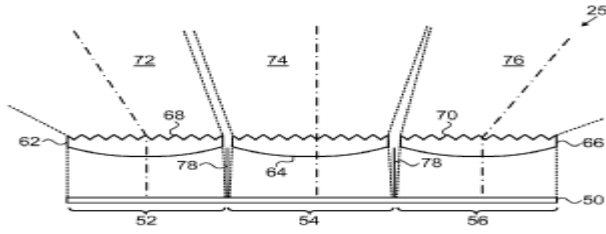

FIG. 3A

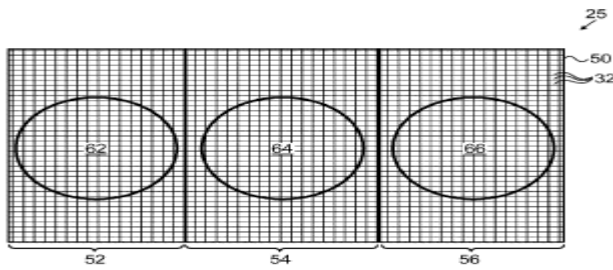

FIG. 3B

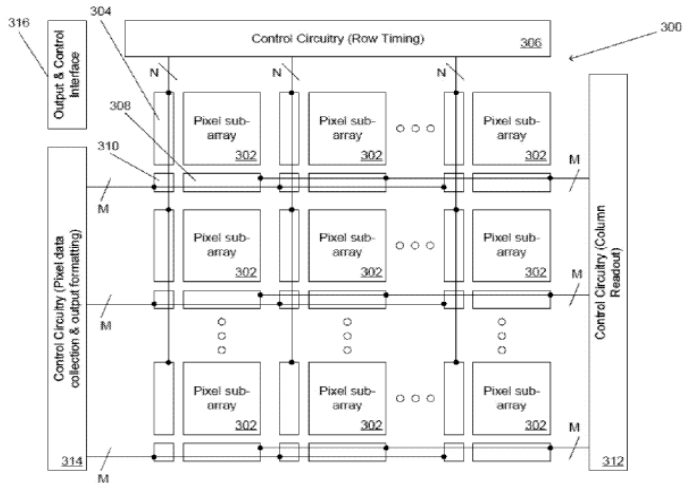
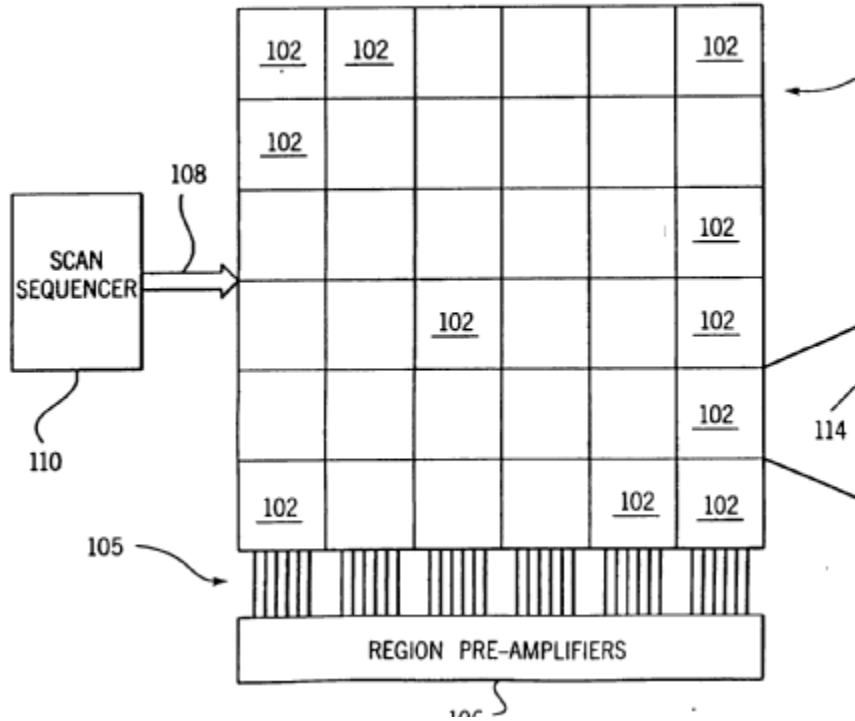
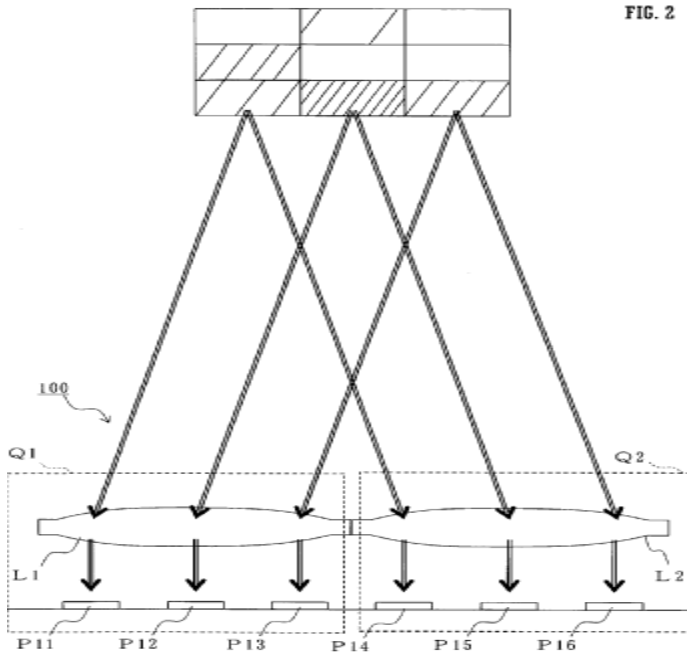

FIG. 3

- large X-ray image sensing unit realized by tessellating several sensor panels;



- image sensing units that form images of the same or at least partially overlapping photographic region upon each of a plurality of pixel regions;



- an imaging unit forms images of the same or at least partially overlapping photographic region upon each of a plurality of pixel regions wherein the pixels are offset at a fraction of the pixel pitch;
- details of correction and alignment between the image sensors and the respective optical systems by selective scanning of the image sensors;
- the image sensors may be not on the same plane or on the same chip and the optical system may comprise mirrors or prisms;
- the image sensors or the different image sensor regions have different imaging characteristics like exposure time, aperture size, gain, resolution;

DATE: JANUARY 1, 2021

PROJECT DP0219

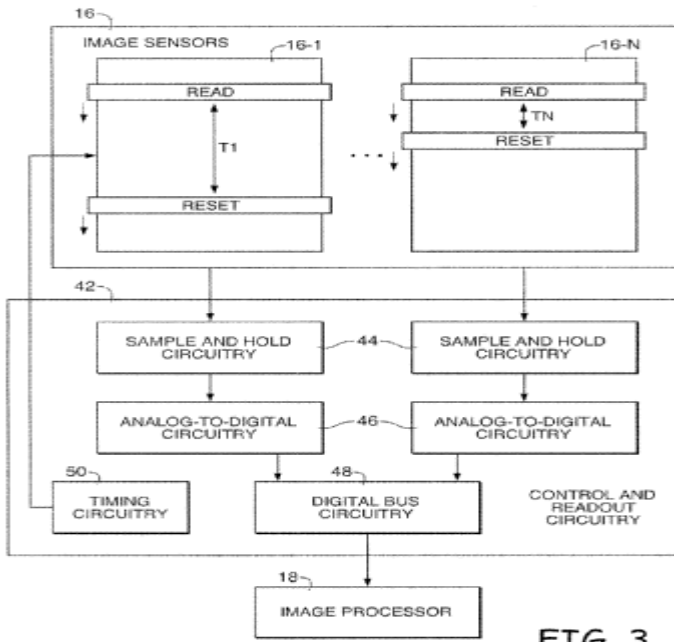

FIG. 3

- the image sensors or the different image sensor regions having different focal planes;
- the image sensors or the different image sensor regions having fields of view of different sizes;

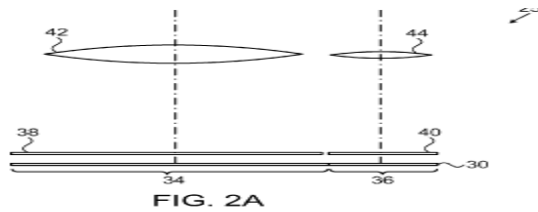

FIG. 2A

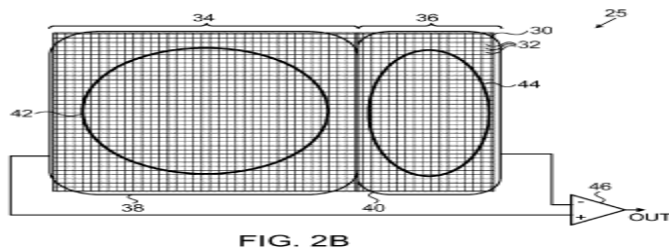

FIG. 2B

- the image sensors or the different image sensor regions have different resolution;

DATE: JANUARY 1, 2021

PROJECT DP0219

- the image sensors or the different image sensor regions have different colours and normally overlapping FOV;
- the image sensors or the different image sensor regions have different colours, one of which is for IR or for depth measurement;
- used in push broom scanning images.

References

Limiting references

This place does not cover:

Linear arrays using abutted sensors	H04N 5/3692
Colour picture signal generators with more than one pick up device	H04N 9/09

Informative references

Attention is drawn to the following places, which may be of interest for search:

Constructional details of television cameras	H04N 5/2251
Cameras using two or more image sensors	H04N 5/2258
Modular detectors for measuring radiation intensity	G01T 1/243

H04N 5/343

Definition statement

This place covers:

image sensors comprising or being switchable between different readout modes like interlaced or non-interlaced mode, high- or low-resolution mode, etc.

One of the modes can be related to readout of specific pixels only, for example mode for reading out focussing pixels or exposure pixels.

The switching between different modes can be initiated, for example:

- upon change of the camera mode - auto exposure, auto focus, AWB, preview mode, video/still picture mode or
- upon scene parameters like motion or object detection.

Special rules of classification

If the scanning mode is controlled in response to scene parameters, [H04N 5/351](#) should be assigned as well.

H04N 5/345

Definition statement

This place covers:

details of partially reading an SSIS during one frame or sub-frame.

The parent group [H04N 5/345](#) should be assigned for the cases, for example, where the image sensor performs:

- scanning different regions of an image sensor with variable resolution, i.e. the regions of the image have different resolutions.

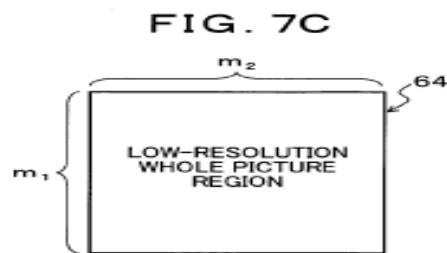
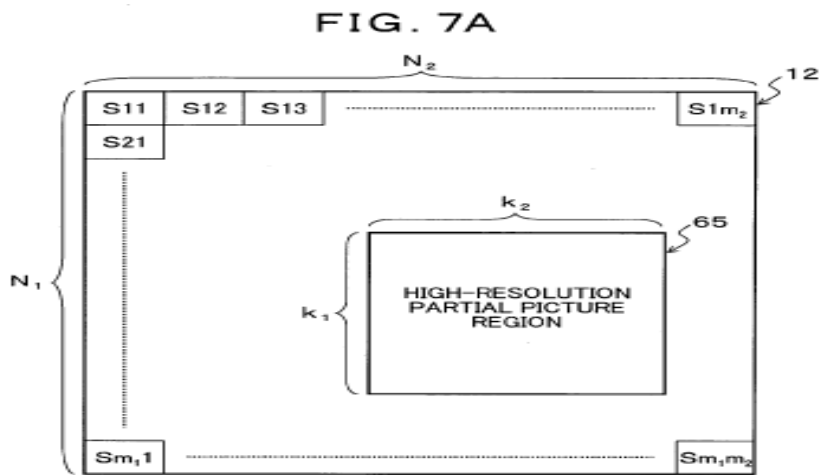

Special rules of classification

This group should be added in combination with [H04N 5/3591](#) if the invention is related to control of blooming of pixels that are not readout.

H04N 5/3452

Definition statement

This place covers:

- scanning details for performing interlaced scanning or for reading only every N-th line of pixels in a frame.

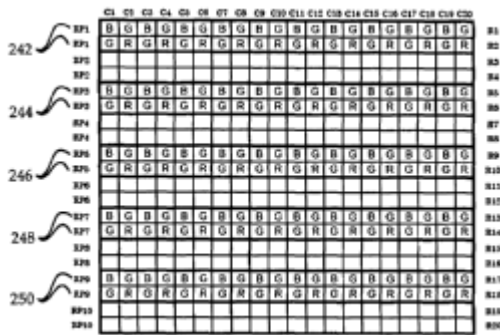

Special rules of classification

If the interlaced scanning is combined with binning of the neighbouring pixels, the code [H04N 5/347](#) shall be added as well. However, if all pixel signals are readout (provided to the column output lines or to the charge transfer lines of the CCD), and then some of these are added or binned, then only [H04N 5/347](#) should be given.

H04N 5/3454

Definition statement

This place covers:

- scanning details of image sensor for performing electronic zooming;

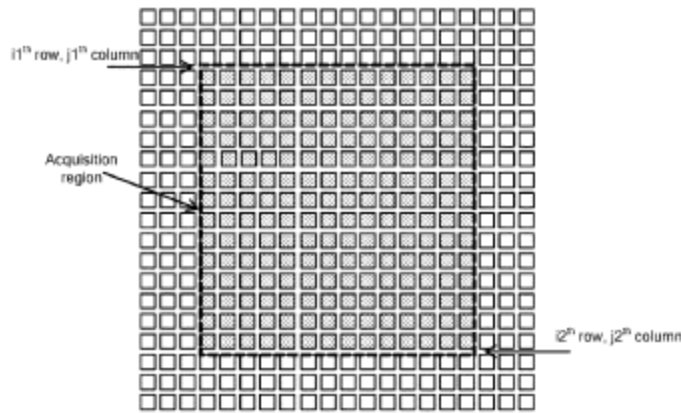

- dynamic vision sensors (DVS): scanning individual pixels or pixel regions based on image data, such as based on detection of time events, level change or exposure level. The figure below shows an example of a pixel for such sensor.

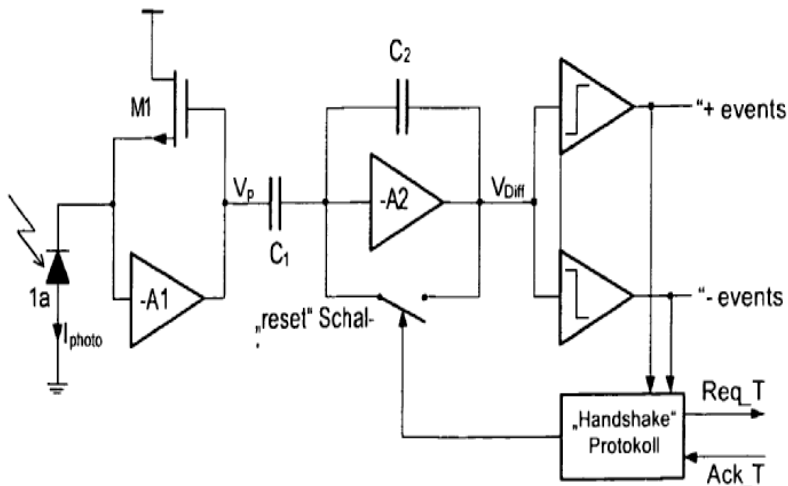

H04N 5/3456

Definition statement

This place covers:

- scanning details for thinned-out reading of pixel signals.

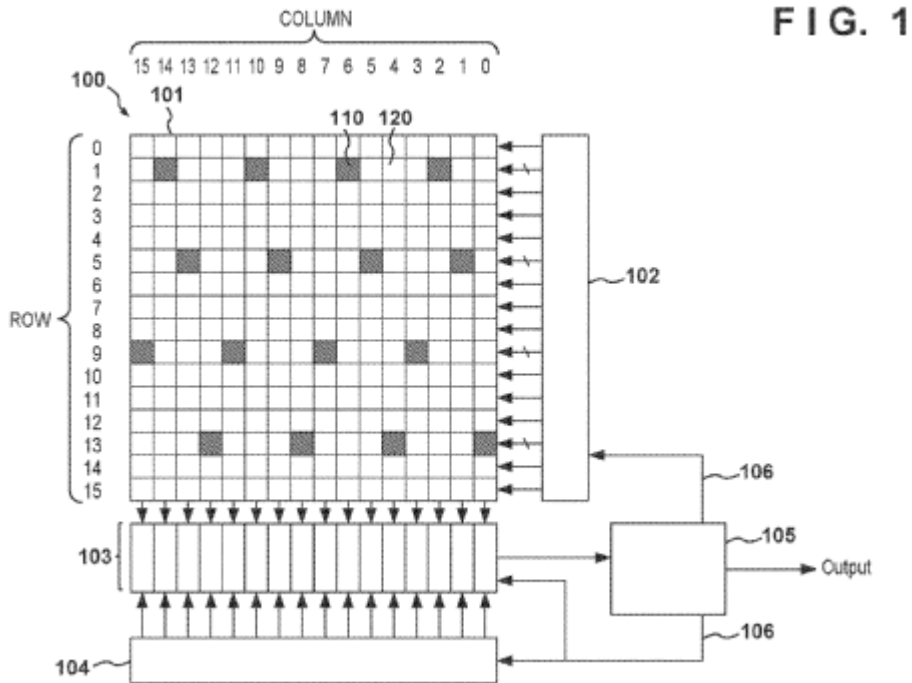

H04N 5/347

Definition statement

This place covers:

binning charges in CCD sensors wherein:

- the colours of the colour filter array are preserved;
- the colours of the colour filter array are mixed;
- weighted addition or low pass filtering is performed.

binning of charges or adding signals in CMOS sensors wherein:

- the colours of the colour filter array are preserved;
- the colours of the colour filter array are mixed;
- weighted addition or low pass filtering is performed.

binning of charges in CMOS sensors wherein:

- charges of different photodiodes are added to a shared floating diffusion;
- a photodiode is connectable to a different shared floating diffusion.

combining of pixel voltage or current signals in CMOS sensors wherein:

- the combining is implemented in the ADC – typically the counter or the memory of the ADC is arranged to perform addition of the pixel signals;
- the combining is implemented in a column amplifier;
- column processing analogue circuits are used to perform addition in h- or v- direction;
- summing of the currents of several source followers is used.

H04N 5/349

Definition statement

This place covers:

- circuits and arrangements for increasing the resolution by shifting the sensor relative to the scene wherein the micro-scanning or pixel shift is implemented by moving optical parts of the camera. The micro-scanning or pixel shift is implemented by moving the sensor, wherein the resolution is increased in scanning devices by moving or exposing at subpixel positions, wherein the resolution is increased by using the relative motion of the images captured caused by the camera shake.

H04N 5/353

Definition statement

This place covers:

details of control of the integration time, in particular:

- details of performing global shutter operations in an image sensor;
- details of performing rolling shutter operations in an image sensor;
- integration time control and synchronisation of the electronic shutter in combination with a light source;
- integration time control and synchronisation of the electronic shutter in combination with mechanical shutter control;
- integration time control and synchronisation of the electronic shutter in function of motion in the scene;
- coded exposure for flutter camera.

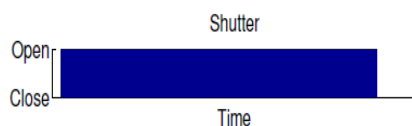

Traditional Exposure

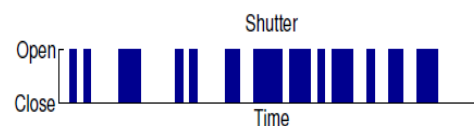

Coded Exposure

H04N 5/3532

Definition statement

This place covers:

- details of controlling rolling shutters.

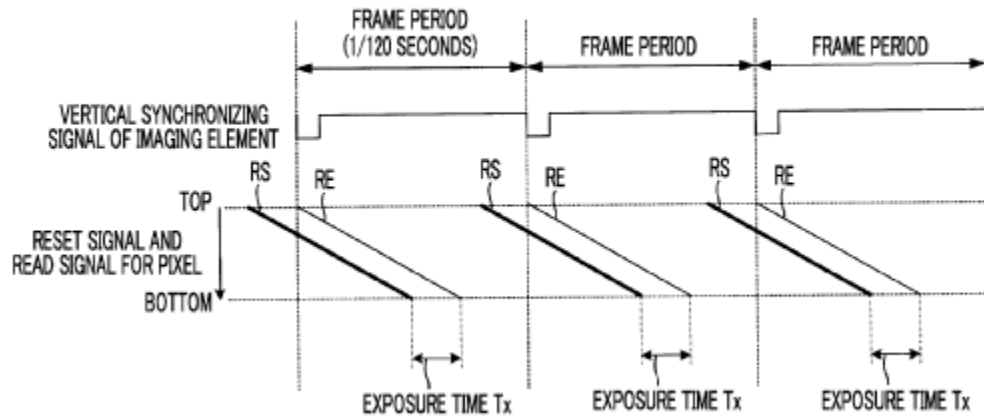

H04N 5/3535

Definition statement

This place covers:

details of controlling the integration times of different regions of the image sensor wherein:

- the different regions can be predetermined;
- the different regions can be dynamically selected, for example, by exposure conditions, ROI, speed, user selection;
- the integration time is controlled for each pixel.

Relationships with other classification places

If the control of the integration times is related to extension of dynamic range, a code in [H04N 5/355](#) is needed.

H04N 5/3537

Definition statement

This place covers:

details of controlling the integration times depending on the colour of the pixel.

DATE: JANUARY 1, 2021

PROJECT DP0219

H04N 5/355

Definition statement

This place covers:

details of controlling the dynamic range of the image sensor.

The dynamic range is the ratio of the light reflection from the brightest to the darkest point in the image, measured in densities (the logarithmic indication of the ratio) or in aperture steps (f-stops) (1 aperture step = approx. 0.3 densities).

The number of digital levels corresponding to a fixed number of (256) brightness levels is also a characteristic related to the dynamic range and it is derived from the Opto Electronic Conversion Function. The Opto Electronic Conversion Function (OECF) describes the property of the image sensor to convert the brightness of the scene into digital values.

H04N 5/35509

Definition statement

This place covers:

- image sensors comprising pixel circuits having a non-linear response;
- driving and control thereof.

The non-linear response can be achieved in different ways, for example, by using a specific photodetector, by controlling the reset or the transfer gate driving signals, by controlling the gain, or by using non-linear amplifiers.

Relationships with other classification places

Details of the pixel circuits are classified in [H04N 5/3745](#).

Details of control of the charge storable in the pixel are classified in [H04N 5/3559](#).

While [H04N 5/35536](#) is toward extending the dynamic range by using multiple exposures, [H04N 5/35509](#) is defining the response characteristic or (the Opto Electronic Conversion Function) of the sensor during a single exposure.

H04N 5/35518

Definition statement

This place covers:

- image sensors comprising pixel circuits having a logarithmic characteristic;
- image sensors comprising pixel circuits having a linear log characteristic;
- driving and control thereof.

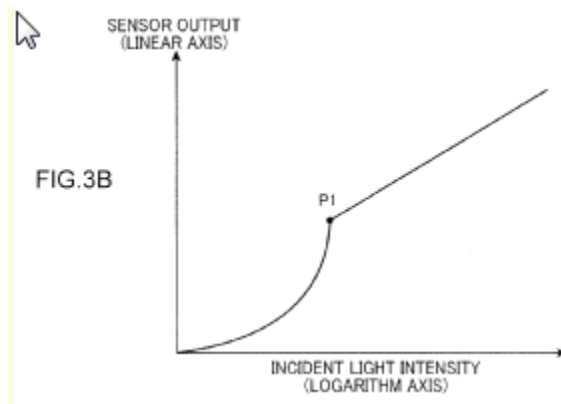

DATE: JANUARY 1, 2021

PROJECT DP0219

H04N 5/35527

Definition statement

This place covers:

- image sensors comprising pixel circuits having multi-slope characteristics;
- driving and control thereof.

H04N5/35536

Definition statement

This place covers:

- details for driving and control of image sensors wherein the dynamic range is extended by multiple exposures.

The term exposure is not limited to exposure time but rather specifies the overall amount of detected light, which further depends on the pixel size, pixel sensitivity, conversion gain, etc.

References

Limiting references

This place does not cover:

Combination of exposures for increasing the dynamic range	H04N 5/235
---	----------------------------

H04N 5/35545

Definition statement

This place covers:

image sensors and driving circuits therefor:

- provided with pixels for multiple exposures, like long- and short-time exposure pixels, high- and low-sensitivity pixels;
- wherein a pixel of the array is read out non-destructively several times within a frame to provide multiple exposures;
- wherein a pixel of the array is partially readout (partial charge transfer or charge skimming) during the exposure time.

Relationships with other classification places

While [H04N 5/3535](#) is about control of exposure time in different regions of the image sensor, [H04N 5/35545](#) is for the cases where the pixel signals of the long and short exposure pixels are combined in such a way that a new high dynamic range pixel signal is generated. Hence, if a partial or non-destructive readout is used only for setting the exposure period of the pixel, [H04N 5/3535](#) should be assigned.

H04N 5/35554

Definition statement

This place covers:

image sensors and driving circuits therefor:

- provided with pixels for multiple exposures, such as long and short exposure time pixels;

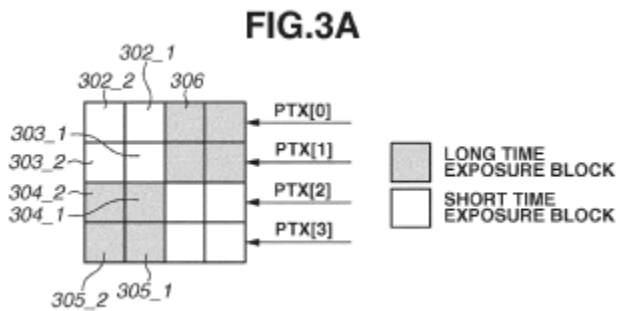

- provided with a pixel that is read out non-destructively several times during the exposure period and the read out signals are used in combination to generate a high dynamic range signal;
- provided with a pixel that has a charge partially transferred to a storage node (charge skimming) during the exposure period and the signals from the partial readout and at the end of exposure are used in combination to generate a high dynamic range signal.

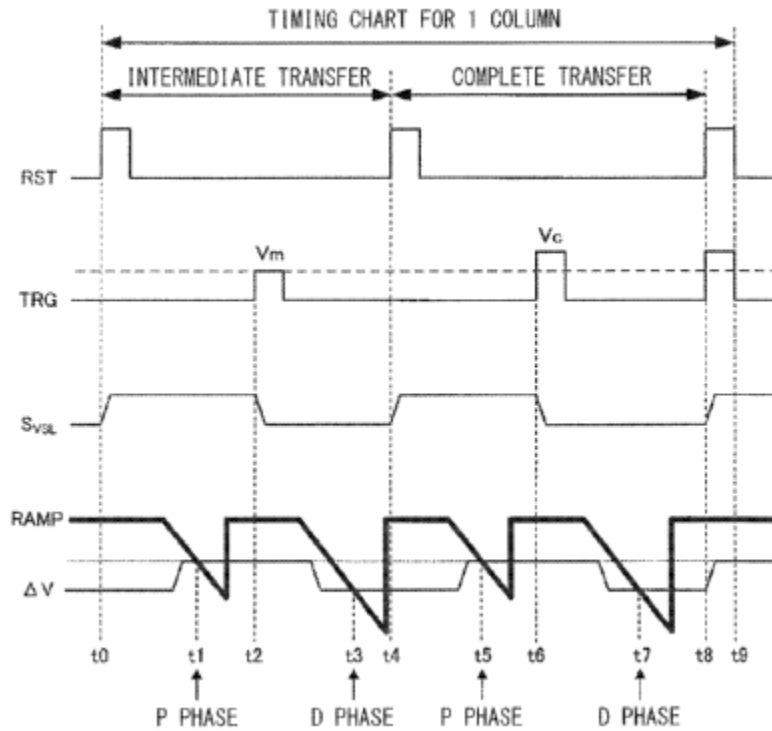

H04N 5/35563

Definition statement

This place covers:

image sensors and driving circuits therefor comprising pixels having:

- different sensibilities,
- different sizes,
- different conversion gains

if the combination of the signals of these pixels are used to generate a HDR signal.

H04N 5/35572

Definition statement

This place covers:

driving and control of image sensors for sequentially taking multiple exposures for extending the dynamic range. The signals from the multiple exposures can be stored in the pixel or outside of the pixel array.

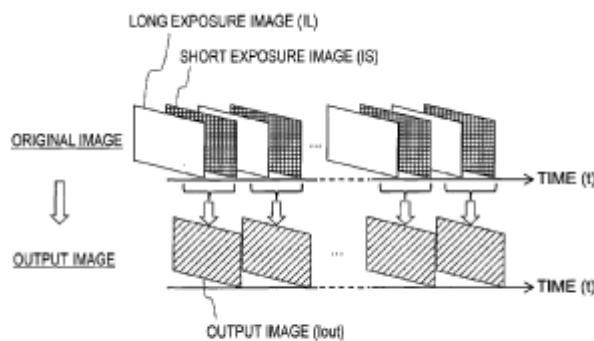

Fig. 5

H04N 5/35581

Definition statement

This place covers:

- details of controlling the image sensor for sequentially capturing images with low and short integration times.

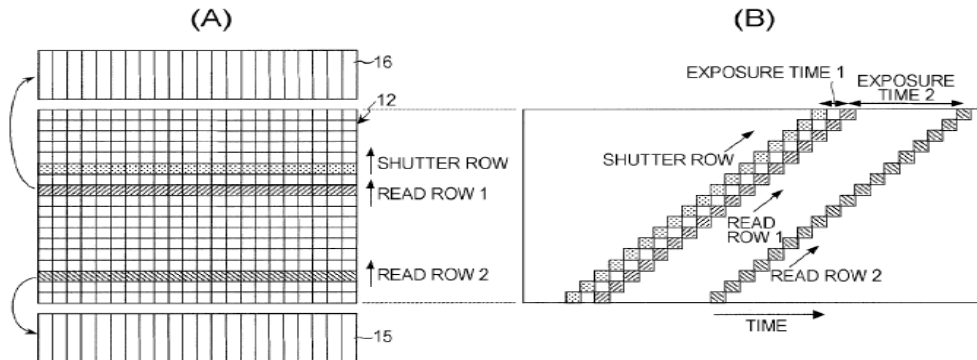

H04N 5/3559

Definition statement

This place covers:

- details related to image sensors comprising pixels that can modify the charge conversion ratio of the floating node. If a transfer gate is used, the amount of electric charge generated in the photoelectric converter PD is not controlled, but rather the charge to voltage conversion ratio of the floating diffusion.

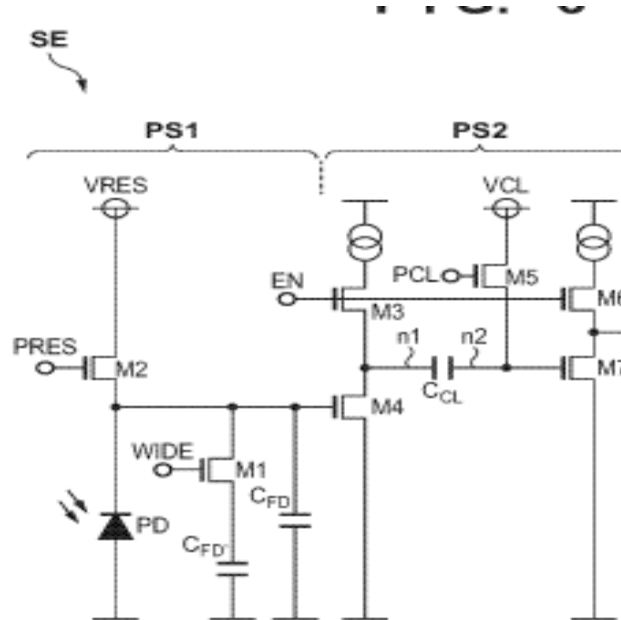

- details related to image sensors comprising pixels which can store and read out overflow charges.

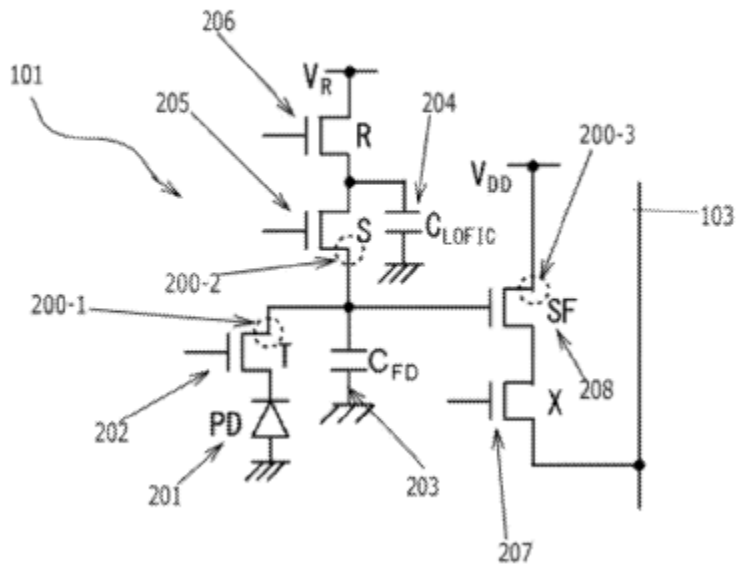

DATE: JANUARY 1, 2021

PROJECT DP0219

Relationships with other classification places

- If two or more photoelectric converters or two neighbouring pixels are connected together for performing binning, [H04N 5/347](#) should be assigned. However, if floating diffusions from different pixels are connected to one photoelectric converter, then [H04N 5/3559](#) should be assigned.
- Details related to control of blooming are to be classified in [H04N 5/3591](#).
- If the voltage level of the transfer gate or of the reset gate is controlled, the amount of charge storable in the photoelectric converter will also be controlled. However, in this case [H04N 5/35509](#) only must be assigned.

H04N 5/3572**Definition statement***This place covers:*

- circuits for detecting and correcting flare;
- circuits for detecting and correcting shading and vignetting;
- circuits for detecting and correcting geometrical distortions.

References**Limiting references***This place does not cover:*

Suppressing or minimizing noise in picture signal generation	H04N 5/217
Correction of colour aberration from a lens	H04N 9/04517

Informative references*Attention is drawn to the following places, which may be of interest for search:*

Image enhancement performing geometric correction	G06T 5/006
---	----------------------------

Special rules of classification

Although not always specific to SSIS, the noise/distortion produced by a lens is nevertheless classified in [H04N 5/3572](#) and not in [H04N 5/217](#). This has been done to facilitate the search. Corrections of chromatic aberrations, which can also be related to lenses, are classified in [H04N 9/04517](#). All other noise suppression or disturbance minimisation in picture signal generation, e.g. in a camera having an EIS, should be classified in [H04N 5/217](#).

H04N 5/35721

Definition statement

This place covers:

circuits for detecting and correcting noise originating only from the associated optical system involving a transfer functions modeling.

H04N 5/3575

Definition statement

This place covers:

details of circuits for implementing:

- double sampling (DS) – these circuits compensate for offsets caused by the varying characteristics of pixel amplifiers (source followers);
- correlated double sampling (CDS) – these circuits further reduce the kTC (reset) noise;
- multiple sampling – multiple sampling of a reset signal and an image signal from a pixel is used to reduce or average the random noise;
- (correlated) double/multiple sampling function implemented in the analog domain, i.e. by using clamping circuits, or by using separate sampling capacitors for the reset signal and the image signal;

- (correlated) double sampling function implemented at least partially in the ADC;
- (correlated) double sampling function implemented in the digital domain.

Relationships with other classification places

If the specific position of the CDS in the image sensor is to be classified, a respective SSIC architecture code from the group [H04N 5/369](#) should be added.

Correlated double sampling is a noise reduction technique in which the reference voltage of the pixel (i.e., the pixel's voltage after it is reset) is subtracted from the signal voltage of the pixel (i.e., the pixel's voltage at the end of integration) at the end of each integration period, to cancel kTC noise (the thermal noise associated with the sensor's capacitance). Therefore the group [H04N 5/363](#) (reduction of kTC noise) should not be assigned if only CDS is used for kTC noise reduction.

H04N 5/3577

Definition statement

This place covers:

circuits for detecting and reducing electromagnetic interferences and clocking noises.

The electromagnetic interferences can be caused by internal or external to the sensor noise sources, like motors for lens focusing or like.

H04N 5/359

Definition statement

This place covers:

circuits for detecting and reducing excess charges produced by the exposure.

H04N 5/3591

Definition statement

This place covers:

- circuits for control of blooming by resetting charges which are not read out in cases of partial area read out;
- circuits for sweeping out electric charges beforehand so as not to leak while one prior row is being exposed;
- circuits for controlling pixels comprising a storage element for storing the overflow photo-charges – the stored overflow charge is used to extend the dynamic range of image sensor.

References

Informative references

Attention is drawn to the following places, which may be of interest for search:

Partially reading an SSIS array	H04N 5/345
Controlling the amount of charge storable in the pixel	H04N 5/3559

Special rules of classification

Details related to image sensors comprising pixels that can store and read out overflow charges are to be classified in [H04N 5/3559](#).

H04N 5/3592

Definition statement

This place covers:

anti-blooming drains used in the CCD sensors.

H04N 5/3594

Definition statement

This place covers:

- evacuation of excess charges produced by the exposure via the output lines or the reset lines of addressed sensors.
- Active CMOS pixels sensors may comprise a dedicated reset or overflow transistor directly connected to the photoelectric converter. Such a pixel is known as a 5T pixel.

H04N 5/3595

Definition statement

This place covers:

- circuits for control of smearing in CCD sensors – the smearing noise appears as vertical stripes in the image;
- circuits for control of smearing in CMOS sensors – the smearing noise appears as horizontal stripes in the image and is normally caused by voltage variations or coupling effects caused by sampling or resetting overexposed pixels. It is also called streaking, pseudo-smear or band like pattern noise.

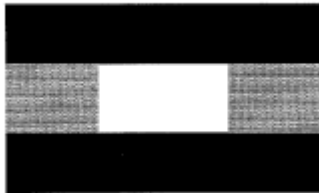

H04N 5/3597

Definition statement

This place covers:

circuits for reduction of residual charges.

DATE: JANUARY 1, 2021

PROJECT DP0219

- “eclipse”, “darkening”, “blackening”, “dark defect”, “black crush”, “black sun”, “dark sun”, “black inversion”, “white-black inversion”, “black dot”, “black grave”, “black core”, “black point”, “tanning phenomenon”, “sunspot phenomenon”, “solar blackening”, “blackening phenomenon”, “spotlight blackening”, “high-brightness darkening”, “black depression”, “black sinking”, “high-intensity blackening”

H04N 5/363

Definition statement

This place covers:

circuits for reduction of reset noise:

- by applying soft reset or combination of soft and hard reset;
- by feeding back the reset readout signal to the floating diffusion.

References

Limiting references

This place does not cover:

Involving a correlated sampling function, e.g. correlated double or triple sampling	H04N 5/3575
---	-----------------------------

H04N 5/365

Definition statement

This place covers:

circuits for detection and reduction of fixed-pattern noise.

H04N 5/3651

Definition statement

This place covers:

circuits and arrangements for correcting and detecting of non-uniformity caused by sensor characteristics, for example:

- different pixel characteristics – sensitivity, gain, offset, response curve;
- different characteristics of sampling circuits, amplifiers, ADCs used for different groups of pixels;
- the resistive or capacitive properties of long readout or control lines.

circuits and arrangements for correcting and detecting of non-uniformity by:

- using dummy pixels and/or dummy structures, not OB pixels for detecting offset variations;
- using correction circuits for correcting gain variations between pixels or groups of pixels;
- performing measurement of the gain variations;
- using correction circuits for correcting offset variations between pixels or groups of pixels;
- performing measurement of the offset variations.

non-uniformity correction modes for:

- measuring the gain responses of the pixels
- measuring the offset responses of the pixels

Relationships with other classification places

There is a certain similarity between the circuits and methods for correcting dark current ([H04N 5/361](#)) and for correcting offset non-uniformities of the pixels.

Since both can be temperature dependent, both can be corrected by using a dark frame.

H04N 5/3653

Definition statement

This place covers:

- circuits and arrangements for correcting and detecting of non-uniformity between adjacent regions or output registers.

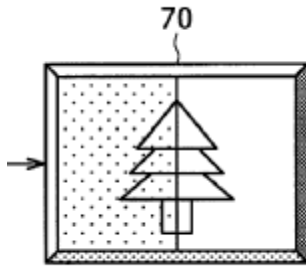

H04N 5/3655

Definition statement

This place covers:

circuits that use dedicated dummy pixels for detecting and correcting non-uniformity;

circuits that use a reference voltage source;

circuits that use a dark image of the scene.

H04N 5/3656

Definition statement

This place covers:

circuits that use information from the captured image for determining non-uniformity characteristics.

- The scene information may be selected from expected uniform regions.
- The scene information can be defocussed to generate uniform like scene.
- The scene can be captured by using pixel shifting, and the difference between the pixels that capture the same part of the scene can be used for detecting non-uniformity.

H04N 5/3658

Definition statement

This place covers:

details of reducing column or line fixed pattern noise.

This noise is caused by different characteristics of column parallel circuits.

H04N 5/367

Definition statement

This place covers:

circuits for correction of defects caused by:

- defects or non-responsive pixels
- defects in readout circuits
- defects in the scanning circuits or control lines

H04N 5/3675

Definition statement

This place covers:

details of circuits that detect defects such as non-responsive pixels on the fly by using the image signal.

DATE: JANUARY 1, 2021

PROJECT DP0219

H04N 5/3696

Definition statement

This place covers:

SSIS with comprising dedicated pixels or control thereof:

- for auto white balance detection
- for exposure detection
- for storing additional non-volatile information
- for triggering of an exposure

SSIS with:

- non-planar (fovea) or curved pixel layout
- with non-identical or non-equidistant pixels distributed over the pixel array

References

Limiting references

This place does not cover:

Imager structures	H01L 27/146
-------------------	-----------------------------

Informative references

Attention is drawn to the following places, which may be of interest for search:

Extending dynamic range with pixels having different sensibilities within the sensor	H04N 5/35563
--	------------------------------

DATE: JANUARY 1, 2021

PROJECT DP0219

H04N 5/36961

Definition statement

This place covers:

SSIS comprising phase difference pixels.

SSIS comprising only phase difference pixels – i.e. all pixels comprise more than one photodiode per micro lens. The photodiodes can have shared amplifiers or can be connected to different (shared) amplifiers.

References

Application-oriented references

Examples of places where the subject matter of this place is covered when specially adapted, used for a particular purpose, or incorporated in a larger system:

Focusing based on the difference in phase signals	H04N 5/232122
---	-------------------------------

Informative references

Attention is drawn to the following places, which may be of interest for search:

Systems for automatic generation of focusing signals using different areas in a pupil plane	G02B 7/34
---	---------------------------

H04N 5/36963

Definition statement

This place covers:

details of pixels for detecting dark current only.

Not all dummy pixels detect dark current and therefore such pixels should not be classified here.

H04N 5/3698

Definition statement

This place covers:

details of circuitry:

- for controlling the power supply;
- for controlling the control signal levels;
- for controlling different bias and reference voltages.

H04N 5/37213

Definition statement

This place covers:

details of transfer registers.

details of readout registers:

- having for example changeable transfer direction;
- electron multiplying CCD.

split readout registers.

multiple readout registers:

- for readout in H and V directions;
- for reading out if different colours.

H04N 5/3741

Definition statement

This place covers:

details of control lines used for a plurality of control functions, for example:

- a control line used to control the transfer gate of one pixel and to control the reset gate of another one;
- a control line used as power line, pixel select line or column output line.

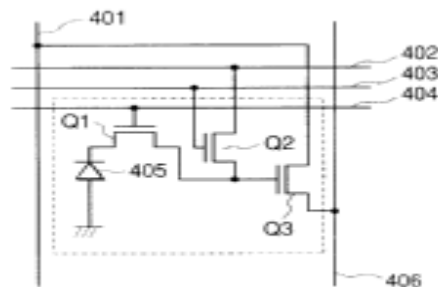

H04N 5/3742**Definition statement**

This place covers:

- an arrangement of a scanning circuit for generating control signals for a multiplexer or an arrangement of switches that connects the column lines of the sensor array to the sensor output. In contrast to the CCD sensors, the addressed type image sensors do not necessarily comprise transfer or readout registers that transfer the image signal to the output.

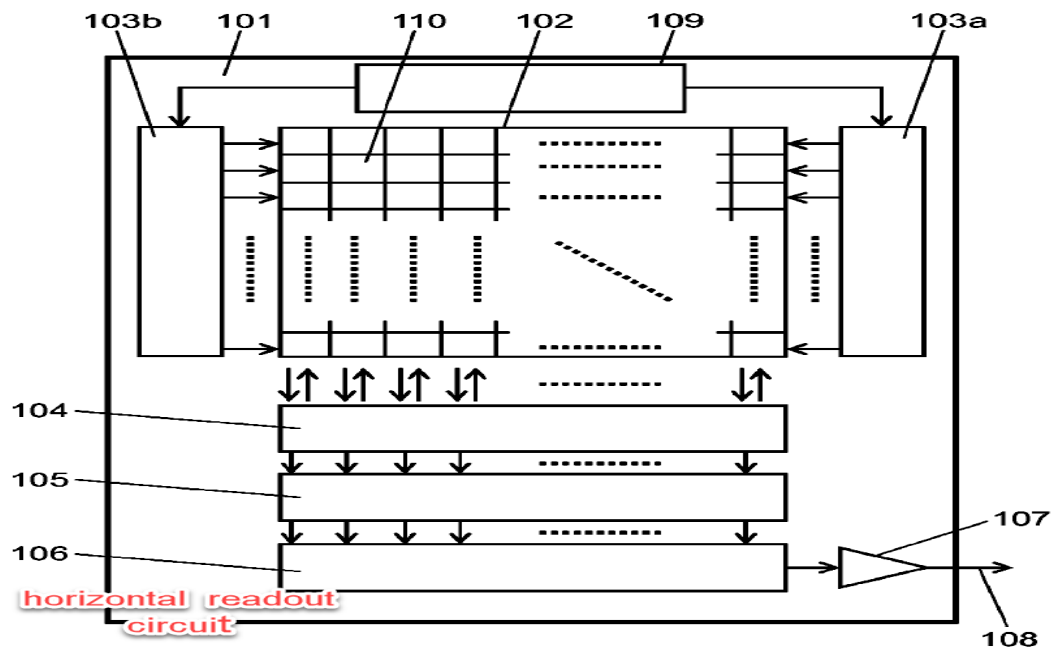

- details of analogue (pixel signal) shift registers and scanning circuits thereof.
- bucket-brigade type shift registers.
- details of digital (signal) shift registers and scanning circuits thereof.
- horizontal and vertical lines to read out the pixel array in x- and y- direction.
- multiple horizontal readout lines for different sensor regions.
- multiple horizontal readout lines for different colours.

DATE: JANUARY 1, 2021

PROJECT DP0219

- details of multiplexer or switches for horizontal scanning used for performing horizontal binning between signals from different column lines.
- details of multiplexer or switches for outputting signals from a column line to different readout line.

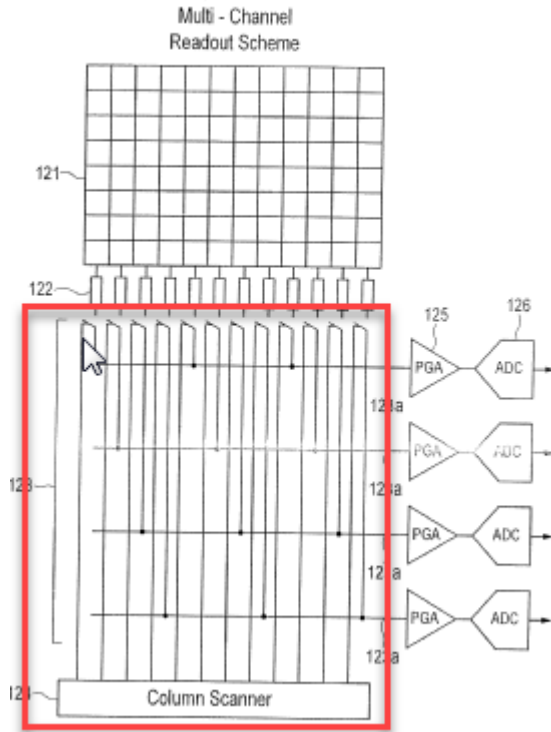

Relationships with other classification places

Circuits like AD converters, correlated double sampling or amplifiers provided for each column are not part of the readout registers, but all these circuits can be part of a circuit called readout circuit. Details of column parallel AD converters, CDS circuits or column amplifier are to be classified in [H04N 5/378](#). [H04N 5/3742](#) shall be used for details as to how the data is transmitted to the output.

DATE: JANUARY 1, 2021

PROJECT DP0219

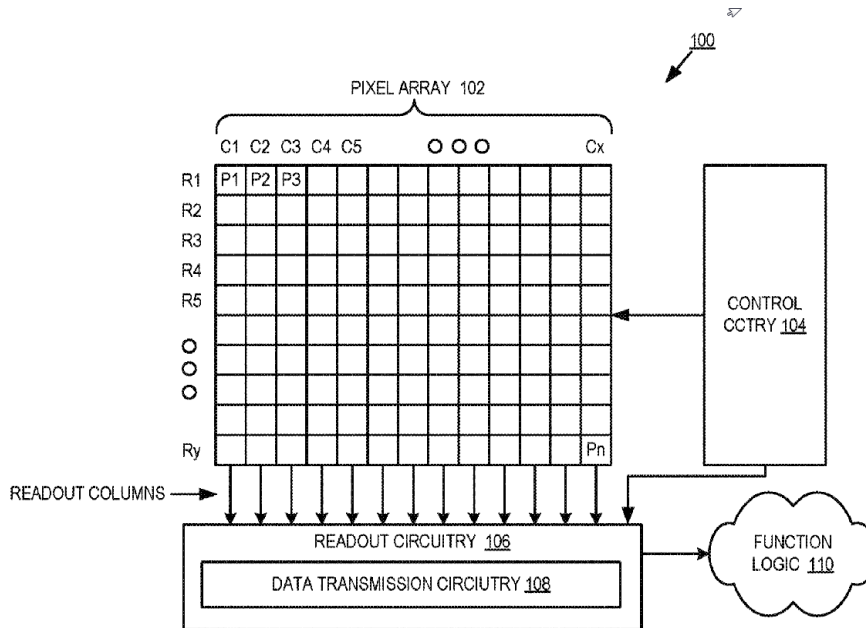

H04N 5/3745

Definition statement

This place covers:

details of pixel circuits and control thereof. Since the pixel circuits known as 3T, 4T, 5T or passive pixels are well known, these pixel structures as such are not classified in this group. However, if the invention is related to some specific properties of these well-known pixels, these pixels should be classified in this group.

The parent group covers pixels characterised by their mode of operation:

- pixels having different modes – e.g. a pixel configurable to work as TOF, as photon counter, as event detection, as integration pixel, etc.;

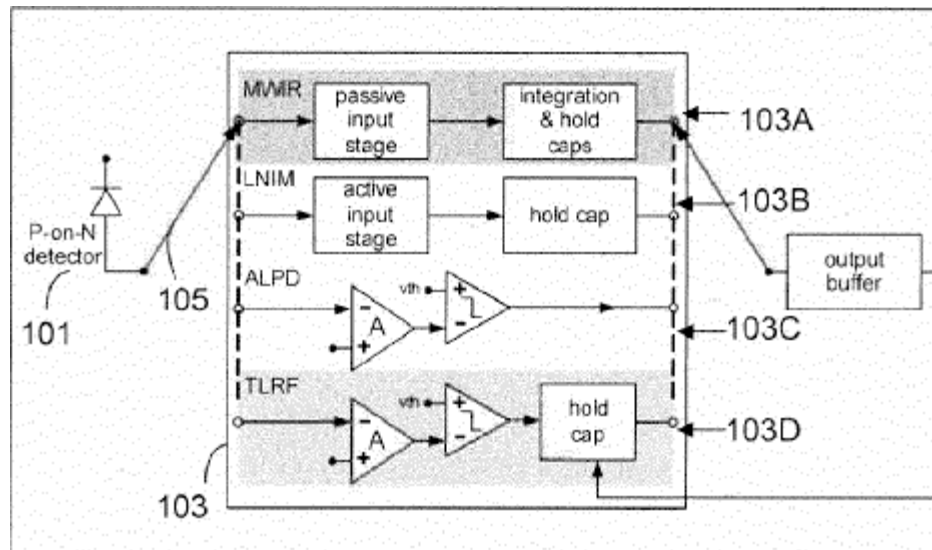

- pixels having different read-out modes.

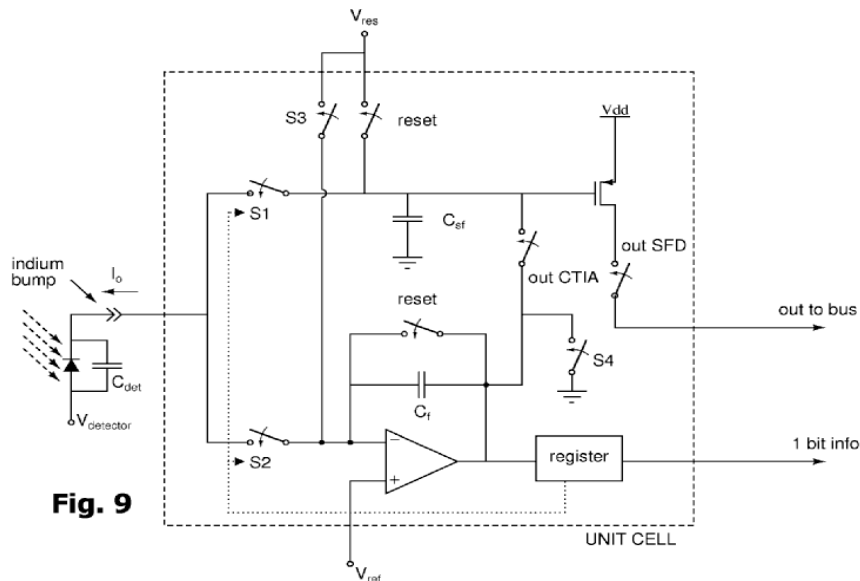

The parent group covers pixel details related to the pixel output interface. For example, pixels:

- having multiple outputs;
- having digital and analogue output;
- having passive and active output, i.e. pixels which can be read out as passive and active pixels.

This parent group covers pixels characterised by the type and the characteristics of the used amplifier. For example, pixels having:

- specific details related to the source follower in the APS and of the source follower transistor, e.g. type of the SF transistor, load of the SF implemented in the pixel, control of the SF voltage;

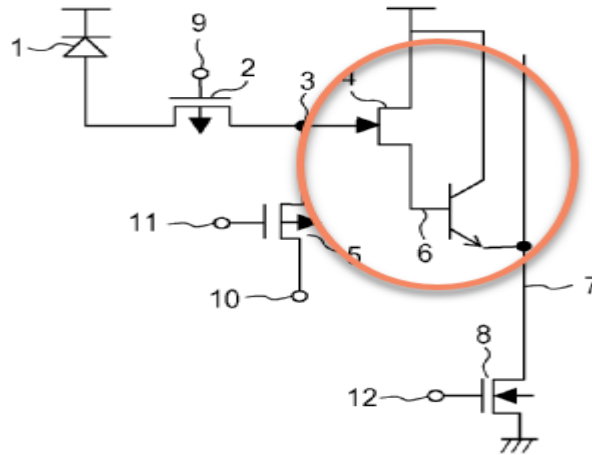

- multi stage amplifier, e. g. two stage source follower;
- multiple source followers per pixels connected in parallel;
- distributed amplifiers, i.e. pixels comprising only part of the amplifier, the remaining part is shared for a group of pixels or for a column of pixels;
- CTIA or common drain amplifiers, not source followers.

The parent group covers pixels characterised by the type and the characteristics of the charge transfer elements. For example, pixels:

- with details of control of the transfer gate;
- with details of transfer gate transistor: enhancement-, p- type;
- with plurality of transfer gates connected in parallel;
- with plurality of transfer gates serially connected.

Note: plurality of transfer gates for connecting additional storage means within the pixel are classified in [H04N 5/37452](#).

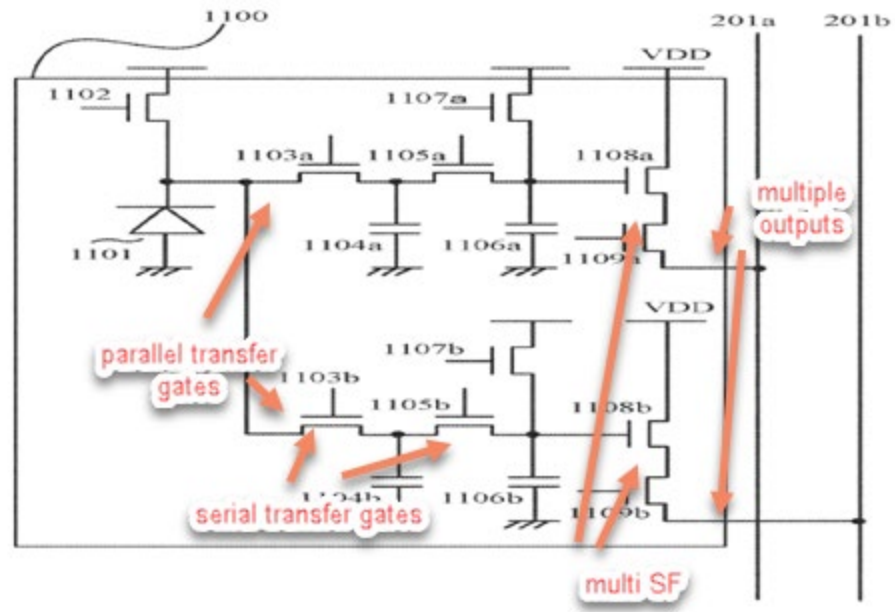

- having direct injection gate.

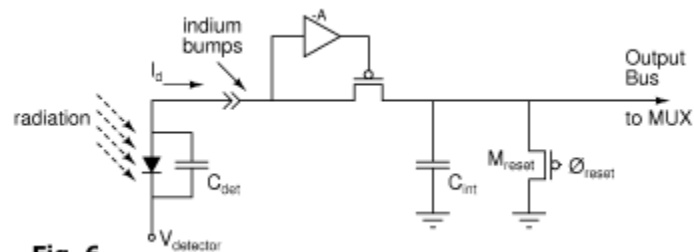

Fig. 6

- having charge multiplying portion.
- having time segregation structure for arrival time measuring.
- reading the photocurrent.

The parent group covers pixels characterised by the type and the characteristics of the reset switch. For example, pixels:

- with reset level control;
- with details of the reset transistor: enhancement-, p- type.

The parent group further covers pixels comprising control circuits using signals from the neighbouring pixels, e.g. for control of pixel conversion gain or exposure time in function of the average signal value of the neighbouring pixels.

The parent group further covers pixels comprising capacitors for applying control signals (RST, SEL) through it.

Special rules of classification

The sensor matrix defined in [H04N 5/3745](#) is not meant to include the associated circuits. An A/D converter in the readout circuit outside the matrix is classified in [H04N 5/378](#) and not in [H04N 5/37455](#).

H04N 5/37452

Definition statement

This place covers:

pixel circuits comprising additional storage means, i.e. storage means other than the floating diffusion.

The storage means can be analogue storage means:

- in the charge domain;

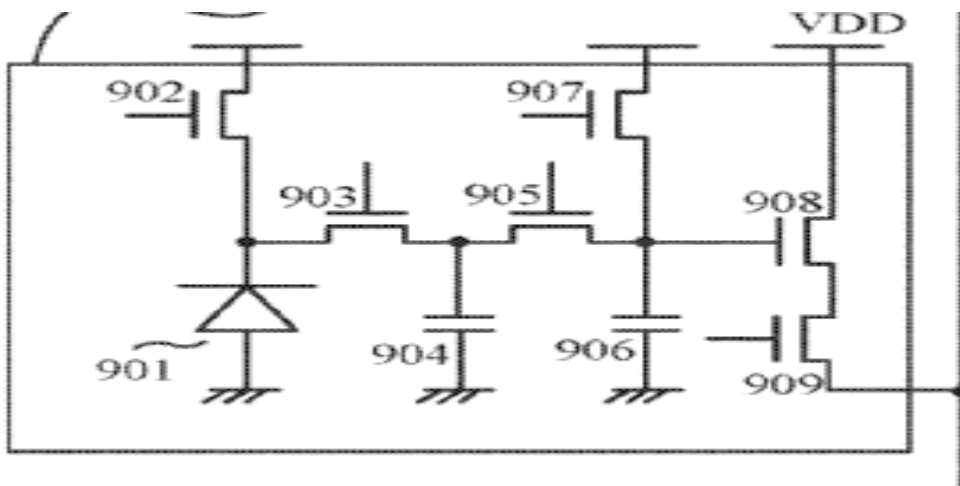

- in the voltage domain, i.e. after the source follower.

The storage means can be digital memories or non-volatile memories.

The storage means are used for different purposes. For example:

- for storing reset and exposure signals for performing CDS;
- for storing several exposure periods;
- for performing high frame rate imaging;
- for performing HDR imaging;
- for storing overflow charges during the exposure period;
- for storing non-destructive readout signals during the exposure period.

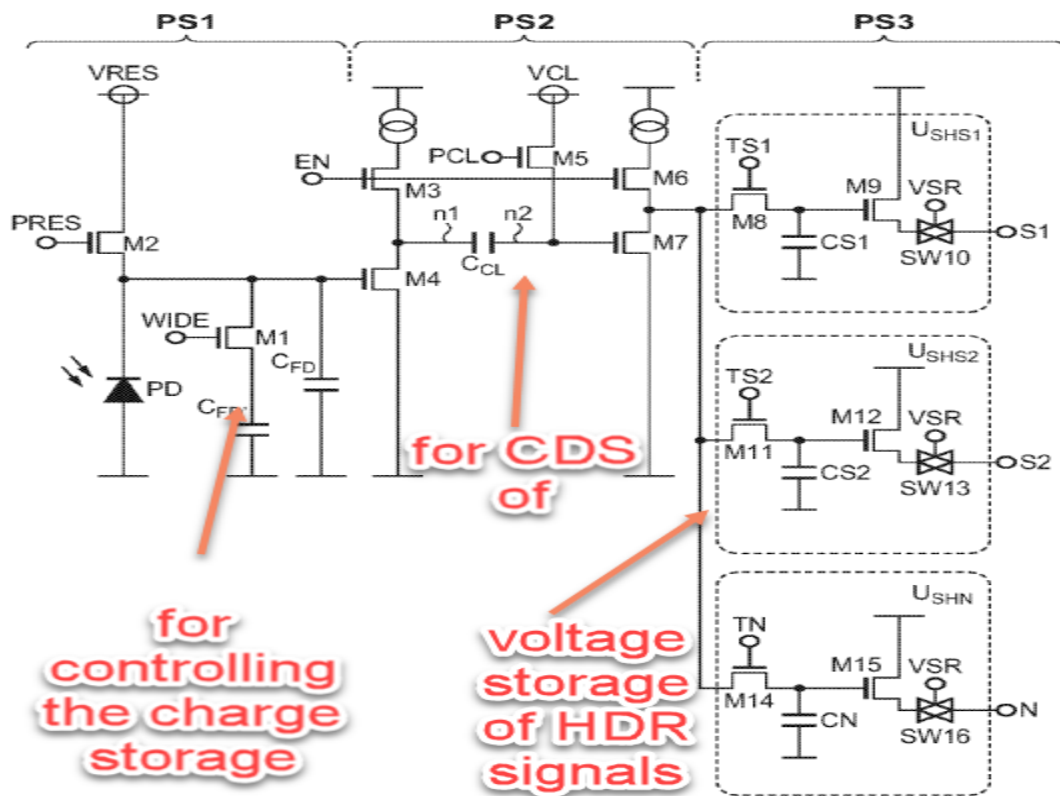

Relationships with other classification places

This group is not used for memories provided in the AD converters. Such pixels are classified in [H04N 5/37455](#).

References

Limiting references

This place does not cover:

Extending dynamic range by controlling the amount of charges storable in the pixel	H04N 5/3559
--	-----------------------------

H04N 5/37455

Definition statement

This place covers:

pixels or group of pixels comprising A/D, V/T, V/F, I/T or I/F converters.

The converters should be at least partially implemented in the pixel array.

This group also covers stacked chip structures in which a pixel or a group of pixels is connected to an A/D converter implemented on a different chip.

This group does not cover image sensors in which a column of pixels is connected to an A/D converter.

A/D converters can be of any type and can be specifically designed for photoelectric pixel circuits and/or to work in combination with other pixel elements like transfer gates, reset gates, source followers, etc.

A/D converters can be used to convert the image signal from the pixel to a digital value.

A/D converters can be used to generate a digital value for controlling different characteristics of the pixel like its exposure time or sensitivity.

Some pixels circuits comprising converters provide an analogue and a digital output or a multiplexed digital and analogue output.

DATE: JANUARY 1, 2021

PROJECT DP0219

The converters convert current or voltage levels to signals with different frequency – current to frequency (I/F) converter or use voltage controlled oscillator to perform voltage to frequency conversion (V/F).

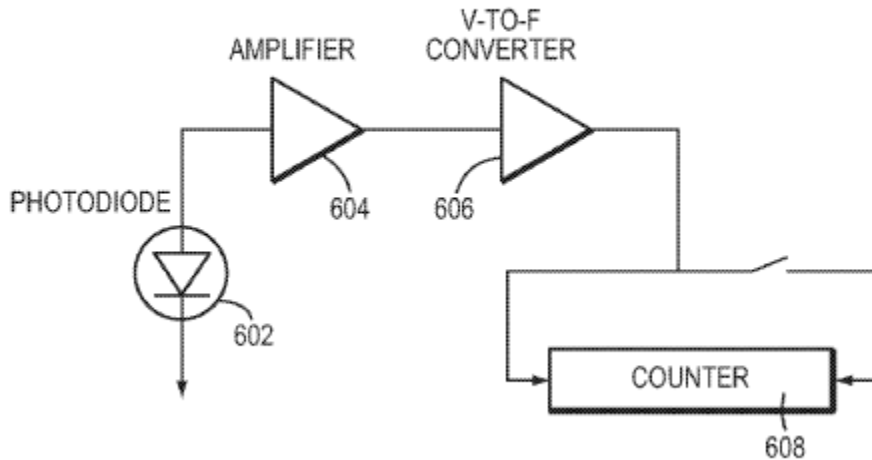

The converters convert the signal from the photo sensor to a time-dependent signal (V/T or I/T converter). These circuits are sometimes called ADC using pulse width modulation (PWM). A comparator measures the duration of the exposure time needed for the pixel to reach a predetermined threshold. The duration of the pulse corresponds to the pixel level. The duration of the pulse can be converted to a digital value by using a counter or to analogue signal using a ramp signal.

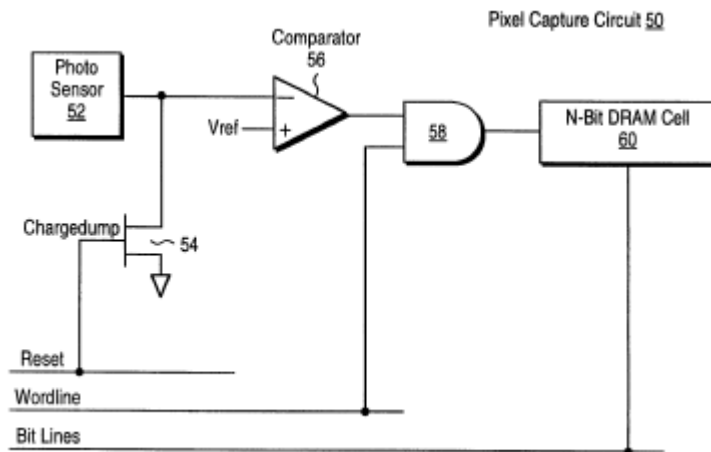

The converters are ADC converters that count the number of exposure periods. These circuits are sometimes also called voltage to frequency converters or ADC using pulse frequency modulation (PFM). The duration of each exposure period is defined by a control circuit that determines when the signal from the photodiode reaches a predetermined threshold. The control circuit normally performs a reset operation and starts the new exposure period. Note that a part of or the entire control circuit can be implemented outside the pixel array.

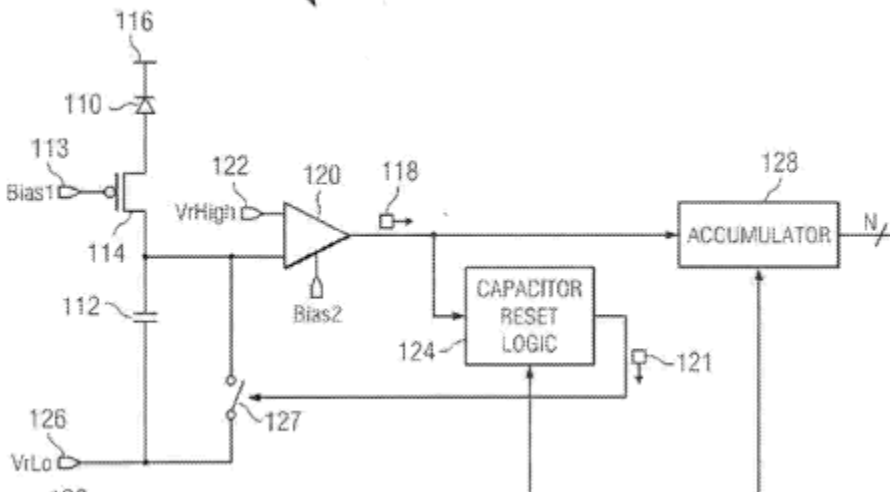

The converters are part of photon counting pixels that generate one bit signals corresponding to a detected photon, and the number of detected photons for a predetermined time is counted to provide a digital value (Details for such pixel circuits can be found in [G01T 1/247](#), [G01J 1/46](#) as a part of a radiation measuring system).

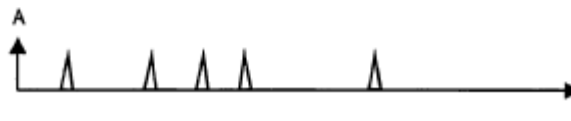
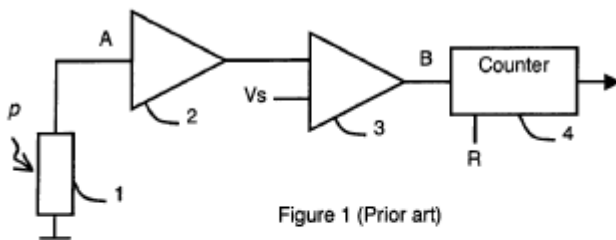

DATE: JANUARY 1, 2021

PROJECT DP0219

The converters are single slope ADCs (Details of single slope ADCs as such can be found in [H03M1/56](#)).

The converters are flash type ADCs.

The converters are sigma delta ADCs.

References

Informative references

Attention is drawn to the following places, which may be of interest for search:

Detector read-out circuitry for measuring X-radiation, gamma radiation, corpuscular radiation, or cosmic radiation	G01T 1/247
Electric circuits for Photometry	G01J 1/44
Analogue/digital converters	H03M 1/12

[H04N 5/37457](#)

Definition statement

This place covers:

pixel structures in which multiple photodiodes are provided. Respective transfer gates are used to transfer the charges accumulated in the photodiodes to a floating diffusion and the floating diffusion is connected to a gate of an amplifier transistor. The amplifier is implemented within the pixel array.

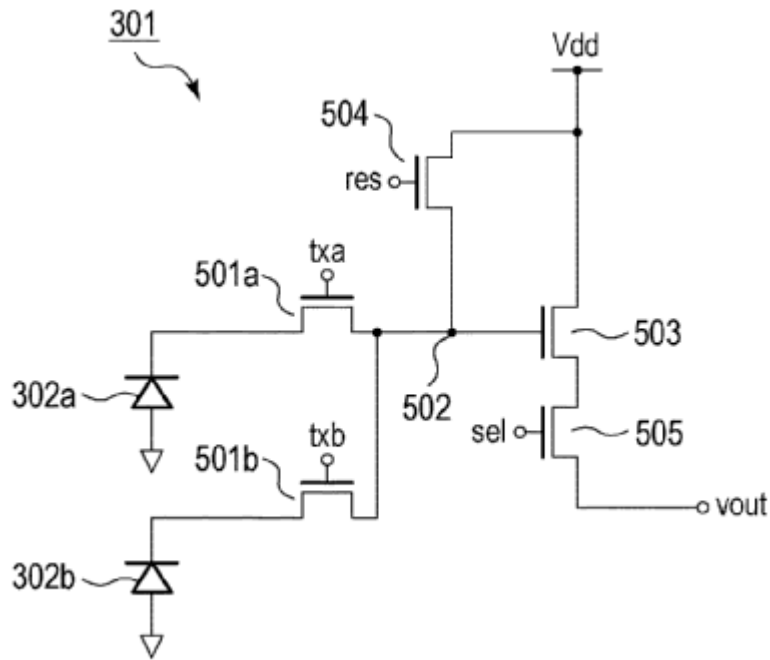

Relationships with other classification places

Passive pixel sensors comprising a shared amplifier pro column are classified in [H04N 5/374](#).

Active pixels sensors comprising column parallel amplifiers are classified in [H04N 5/378](#).

Special rules of classification

Typical examples for shared pixel structures used for different applications, which require additional CPC symbols

Shared photodiodes have different sensitivity	H04N 5/35563
Shared photodiodes are phase detection pixels	H04N 5/36961
Charges of the shared photodiodes are binned in the floating diffusion	H04N 5/347

H04N 5/3765

Definition statement

This place covers:

details of timing or clock signal generating circuits. These circuits drive the row electronics, the column electronics and control the readout of the pixel area.

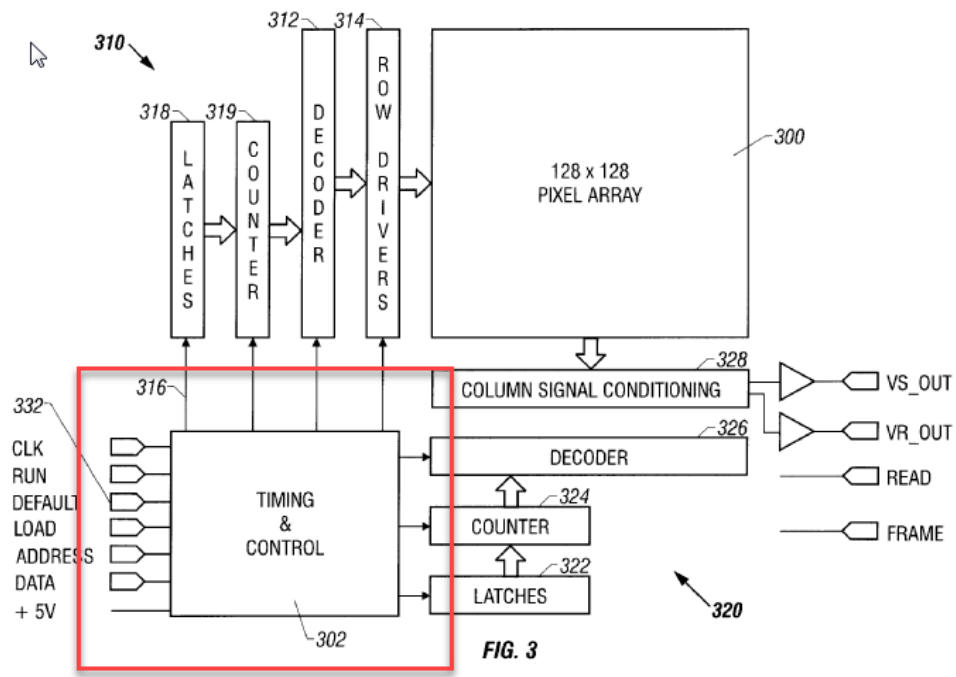

FIG. 3

H04N 5/379

Definition statement

This place covers:

- details of circuits and control thereof adapted for stacked image sensors and the like;
- details of partitioning the image sensor functional blocks like pixel array, scanning circuits, readout circuits, memories between different stacked chips;
- details of a pixel circuitry distributed between different layers;
- details of ADC circuitry distributed between different layers;
- details of specific control arrangements or control lines adapted for stacked sensors.

References

Limiting references

This place does not cover:

Line sensors using abutted sensors forming a long line	H04N 5/3694
--	-----------------------------

2. A. DEFINITIONS (modified)

H04N 5/30

Definition statement

Replace: The existing Definition statement with the following new text.

- circuitry (electronic circuits) and driving details specific to image sensors.

Image sensors find application in Video cameras, Electronic still cameras, Endoscopes, Remote sensing systems, Monitoring cameras, Telecines, Computers, TV telephones, etc.

This group covers circuitry and driving details of image sensors. In particular, the circuitry and driving details of image sensors are directed to the following purpose and functions:

- reading out image data from the image sensor;
- performing image processing within the image sensor;
- control of exposure time by electronic shutter;
- noise removal;
- improvement of resolution;
- extension of dynamic ranges.

Insert: The following new Glossary of terms section.

Glossary of terms

In this place, the following terms or expressions are used with the meaning indicated:

Image sensor	An image sensor is a sensor that detects and conveys the information that constitutes an image. An image sensor may do so by producing a signal that represents location-dependent attenuation of light (as the light passes through or reflects off a medium). The signal is an electric signal such as an electric voltage or current. The light an image
--------------	---

DATE: JANUARY 1, 2021

PROJECT DP0219

	<p>sensor may detect is not limited to visible light, but can be electromagnetic radiation in other wavelengths (e.g., infrared, ultraviolet, X-ray, gamma ray).</p>
--	--

H04N 5/32

Definition statement

Replace: The existing Definition statement with the following new text.

electronic circuitry of X-ray imaging detectors that directly or indirectly detect incident X-ray photons:

- current integrating detectors (CID) or energy integrating detectors (EID);
- photon counting detectors (PCD). Some X-ray PCDs rely on continuous time current monitoring and pulse counting implementation of photon counting. Each pixel typically contains a pulse shaping circuit along with a thresholding system connected to a counter;
- details of generating control signals based on data from the image sensor, like irradiation start/stop detection based on dummy readouts or form signals from specific pixels;
- operation and control of different sensor modes, like entering and control in sleep mode.

Application-oriented references

Replace: The existing Application-oriented references table with the following new table.

Apparatus for radiation diagnosis	A61B 6/00
Investigation of materials using radiation	G01N 23/00
Detecting hidden objects using radiation	G01V 5/0008
Nuclear Magnetic Resonance imaging systems	G01R 33/48
X-ray apparatus or circuits therefor	H05G 1/00

CPC NOTICE OF CHANGES 1008

DATE: JANUARY 1, 2021

PROJECT DP0219

Informative references

Replace: The existing Informative references table with the following new table.

Measuring X-radiation, gamma radiation, corpuscular radiation, or cosmic radiation	G01T 1/00
Measuring X-radiation, gamma radiation, corpuscular radiation, or cosmic radiation with semiconductor detectors	G01T 1/24
Apparatus for taking X-ray photographs	G03B 42/02
X-ray photographic processes	G03C 5/16
Image data processing	G06T
Medical informatics	G16H
Collimators	G21K 1/02
X-ray tubes	H01J 35/00

DATE: JANUARY 1, 2021

PROJECT DP0219

Insert: The following new Special rules of classification section.

Special rules of classification

In many cases it is necessary to add a code for an identified function or circuitry design covered in the group [H04N 5/335](#).

When the X-ray sensor is described with details related to systems for measuring of X-ray radiation with semiconductor detectors, the group [G01T 1/00](#) is to be added, in particular, if details of circuitry for detecting, measuring or adapting the detected signal in order to get a correct signal, e.g. corrections for pile-up, for trapped charges, for dead-time, to determine energy or spatial corrections are described.

H04N 5/33

Definition statement

Replace: The existing Definition statement with the following new text.

image sensors and control thereof for near and far infrared (IR) cameras.

Informative references

Delete: The following existing Informative references table row.

Detection of the presence or absence of infrared radiation, not otherwise provided for	G01J
--	------

Insert: The following new row into the Informative references table.

Radiation pyrometry	G01J 5/00
---------------------	---------------------------

Insert: The following new Special rules of classification section.

Special rules of classification

In many cases it is necessary to add a code for an identified function or circuitry design covered in the group [H04N 5/335](#).

H04N 5/335

Definition statement

Replace: The existing Definition statement with the following new text and images.

- circuitry (electronic circuits) and processing specific to e.g. CMOS or CCD solid state image sensors; includes particular sampling pattern, e.g. windowing; includes noise correction, e.g. defect pixels, dark current correction; includes particular functions achieved by scanning, e.g. electronic shutter, control of the dynamic range.

Solid-state image sensors encompass charge-coupled devices (CCDs), charge injection devices (CIDs), addressable photodiode arrays, Complementary Metal Oxide (CMOS) Image sensors, etc.

DATE: JANUARY 1, 2021

PROJECT DP0219

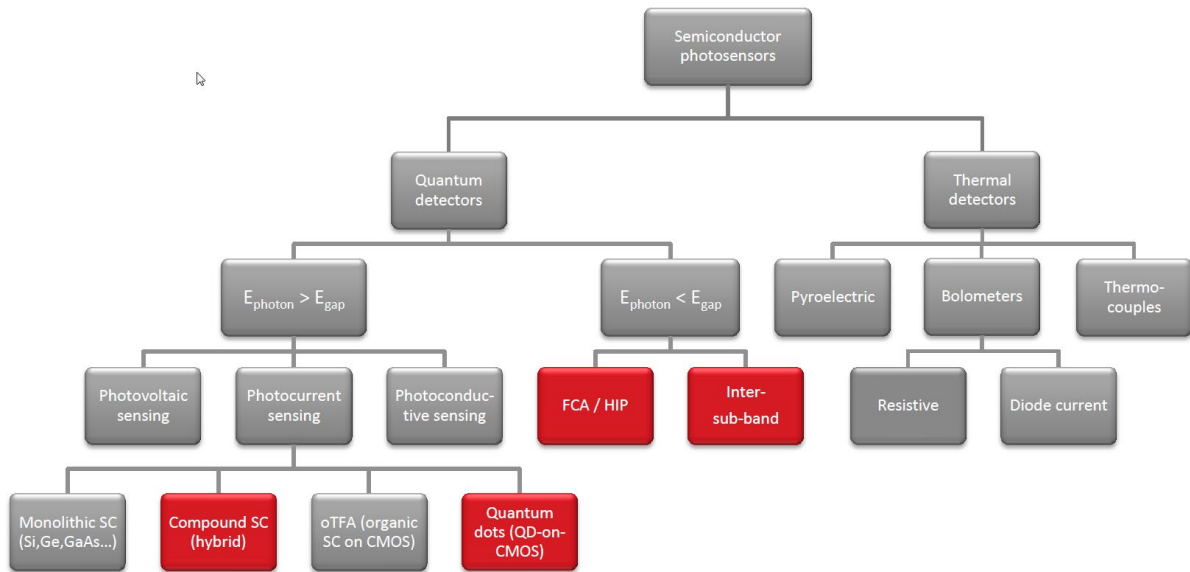

Solid-state image sensors normally capture and output image data as raw image. However, there are special image sensors that capture/processes and output the image data. Details of such sensors are classified in the parent group [H04N 5/335](#), for example:

- image sensors having on-chip compression means for data rate reduction purposes, e.g. DCT, wavelet transformation in the sensor;
- image sensors having on-chip compression means for data rate reduction purposes by outputting differential data, like difference between two exposures or events detecting a predetermined change of the image signal or differences between neighbouring pixels;

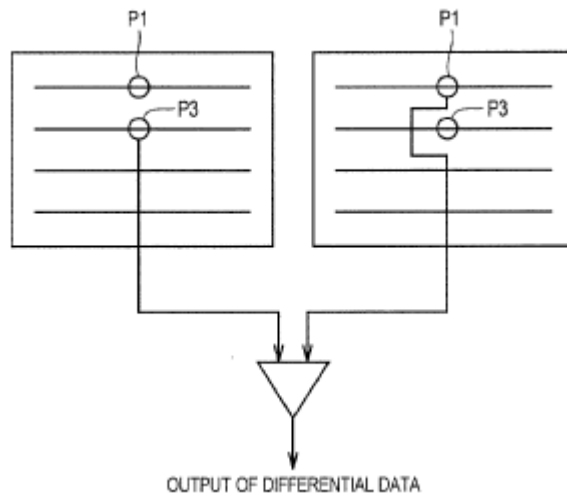

DATE: JANUARY 1, 2021

PROJECT DP0219

- compressive sensing sensors, details of compressive sensing and sparse sampling [H03M 7/3062](#);

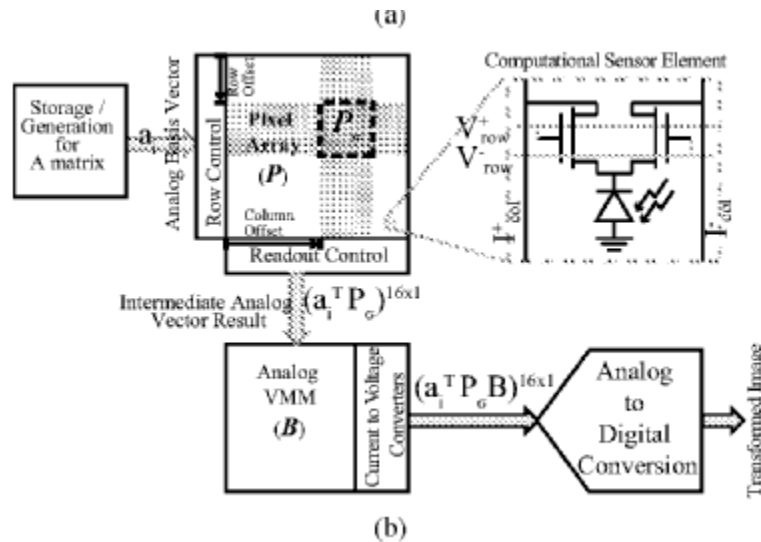

- image sensors performing global operations like histogramming, sorting, region segmentation/labelling, convolution functions, character recognition, or detecting maximum/minimum level;
- image sensors with edge detection in the sensor, for detection difference between pixel signals in spatial domain, for spatial filtering;
- image sensors with motion or event detection in the sensor, i.e. detection change between pixel signals in time.

The parent group [H04N 5/335](#) also covers:

- image sensors comprising a dedicated temperature sensor or being controlled by the sensor temperature.

References

Informative references

Insert: The following new text underneath the Informative references table.

While [H04N 5/335](#) is, inter alia, used for classifying electronic circuits of solid state image sensors and their driving, control and readout, the groups in [H01L 27/00](#) are about technology details related to the implementation of the electronic circuits on a semiconductor chip.

DATE: JANUARY 1, 2021

PROJECT DP0219

Special rules of classification

Replace: The existing Special rules of classification text with the following new text.

- In this group, the first place priority rule is applied, i.e. at each hierarchical level. In the absence of an indication to the contrary, classification is made in the first appropriate place.
- In many cases it is useful to supplement an identified function covered in the range [H04N 5/335](#) - [H04N 5/3675](#) with a code corresponding to the sensor technology CCD/MOS covered in [H04N 5/372](#), [H04N 5/374](#) or [H04N 5/3745](#). As an example, a dark current correction for CCD would be classified in [H04N 5/361](#) and [H04N 5/372](#).
- Two groups specific to colour aspects are presently defined in [H04N 9/04511](#) and [H04N 5/3537](#). It avoids splitting an identical function between [H04N 5/335](#) and [H04N 9/045](#).

H04N 5/351

Insert: The following new Definition statement.

Definition statement

This place covers:

control of image capture conditions such as exposure, gain, response characteristics, resolution, read-out mode depending on the scene properties like brightness, motion, regions of interest.

Insert: The following new Special rules of classification section.

Special rules of classification

If the scanning mode is controlled in response to scene parameters, [H04N 5/343](#) should be assigned as well.

H04N 5/357

Insert: The following new Definition statement section.

Definition statement

This place covers:

- noise processing circuits for reduction of random noise, line noise, high frequency noise, temporal noise caused by voltage drop of power supply or of driving circuits when implemented as part of the image sensor;
- circuits for control of bandwidth of amplifiers or comparators implemented in the image sensor as far as related to the overall noise level of the image sensor;
- noise processing circuits for reduction of optical crosstalk, light leakage, colour mixing and other noises originating from the components of the optical system associated with the image sensor;
- noise processing circuits for reduction of frame to frame variations caused by the image sensor and not by external illumination variations;
- image sensor noise characterization, e.g. methods to derive parametric models to quantify different sensor noise types (such as readout noise or photo-shot noise) in the sensed image according to e.g. Gaussian, Poissonian or uniform probability distribution functions; methods to calibrate and obtain noise levels of sensor data for further use, for example in filtering applications.

H04N 5/361

Definition statement

Replace: The existing Definition statement with the following new text.

- circuits for detection and reduction of dark current;
- circuits performing dark frame subtraction that remove an estimate of the mean fixed pattern, but there still remains a temporal noise, because the dark current itself has a shot noise;

DATE: JANUARY 1, 2021

PROJECT DP0219

- details of circuits using optical black pixels for dark current compensation;
- details of circuits using optical black pixels provided for each pixel or group of pixels.

Insert: The following new Relationships with other classification places section.

Relationships with other classification places

The pattern of different dark currents can result in a fixed-pattern noise ([H04N 5/365](#)). It is important to note that the nature of the dark current is caused by the charges generated in the detector when no outside radiation is entering the detector and only the fixed pattern noise caused by the dark current can be corrected or compensated.

The dark current is temperature, exposure and pixel size dependent.

H04N 5/369

Insert: The following new Definition statement section.

Definition statement

This place covers:

details of SSIS architecture.

H04N 5/36965

Insert: The following new Definition statement section.

Definition statement

This place covers:

- pixels for depth measurement;
- pixels for depth measurement using time of flight.

Informative references

Replace: The existing Informative references table with the following new table.

Lidar systems for mapping or imaging	G01S 17/89
Details of detection, sampling, integration or read-out circuits of lidar systems	G01S 7/4863 , G01S 7/4914

H04N 5/374

Insert: The following new Definition statement section.

Definition statement

This place covers:

- circuits of and for driving, controlling addressed sensors.

There is a wide variety of addressed image sensors using different ways of transforming light to electrical current or voltage. The following aspects are classified in this group.

Active pixels sensors (APS):

- using photodiodes or two terminal semiconductor elements as photodetector;
- using Graphene Layer as photodetector;
- using Photo-conversion layer as photodetector;

DATE: JANUARY 1, 2021

PROJECT DP0219

- having pixels with small full-well capacity (200e-), high conversion gain (1 mV/e-), small pixel size (900 nm), e.g. QIS, Gigavision camera, binary pixels.

Passive pixel sensors:

- using photodiodes or two terminal semiconductor elements as photodetector;
- using bipolar transistors as photodetector;
- using charge injection devices (CID);
- charge modulation, static induction transistor (SIT) or base-stored image sensor BASIS;
- using CMOS-CCD structures;
- using diodes for (row) selection switches.

Bolometers used for far infrared imaging.

This group also covers addressed image sensors:

- comprising an additional frame memory;
- comprising testing structures;
- implemented within a display panel;
- providing specific details of the sensor input/output interfaces;
- providing details of partitioning of the signal processing circuits between the sensor and another chip;
- being a camera on chip.

Insert: The following new References out of a residual place section.

References out of a residual place

Examples of places in relation to which this place is residual:

Noise processing applied when a phenomenon of inverted contrast occurs, e.g. eclipse phenomenon	H04N 5/3598
---	-----------------------------

H04N 5/376

Insert: The following new Definition statement section.

Definition statement

This place covers:

- addressing circuits for pixel arrays.
- CCD timing and clock generating circuits typically generate the vertical and horizontal sync signals VT, VH which determine the timing of vertical and horizontal scanning operations. A further driver circuit generates driving signals that force the CCD to transfer the information through the transfer registers. The parent group covers circuits for generating the driving signals and details related to the said driving signals or pulses.

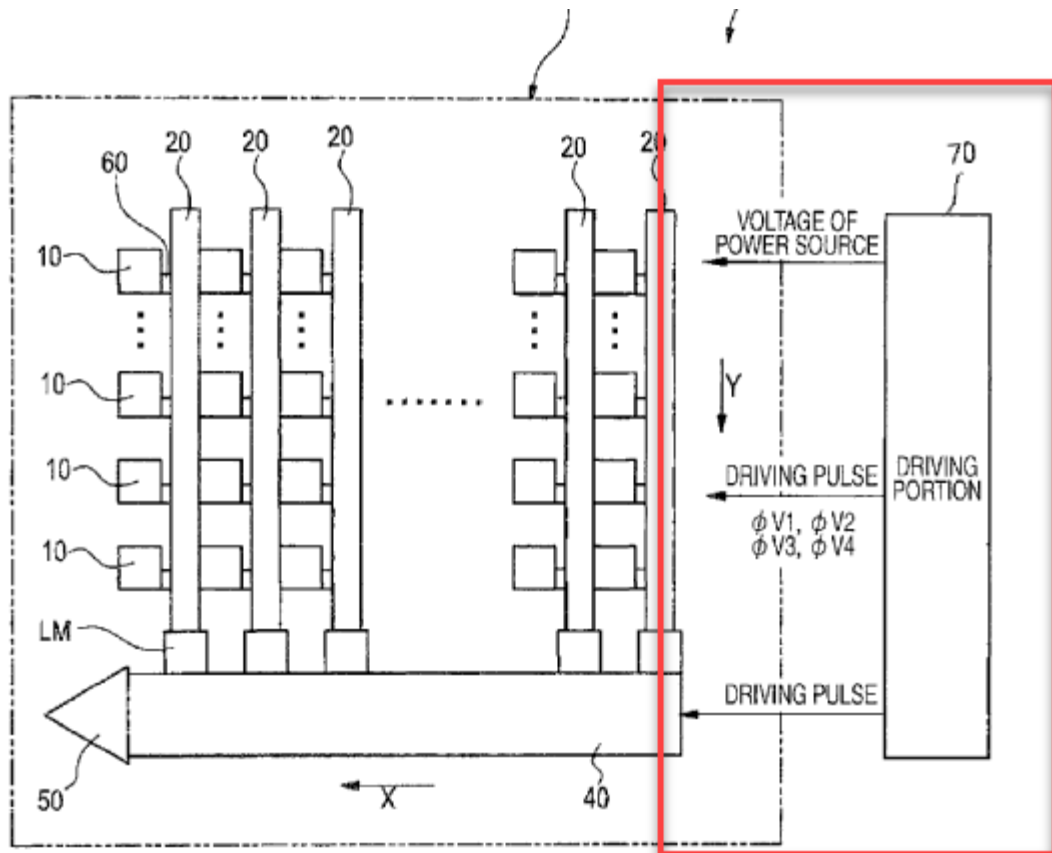

- Addressed image sensors like CMOS image sensors are using row and column scanning or addressing circuits.

- The column scanning/addressing circuits are only used to provide row pixel data to the output of the sensor.
- The row scanning/addressing circuits, in addition to the row select signals, provide further control signals to the pixels such as transfer gate (TG) or reset (RST) signals.

The parent group covers:

- details of scanning/addressing circuits for addressed image sensors;
- details related to the electronic circuitry of the scanning circuits, multiple scanning circuits, details related to the generation of driving pulses for TG, RST, ROW SEL.

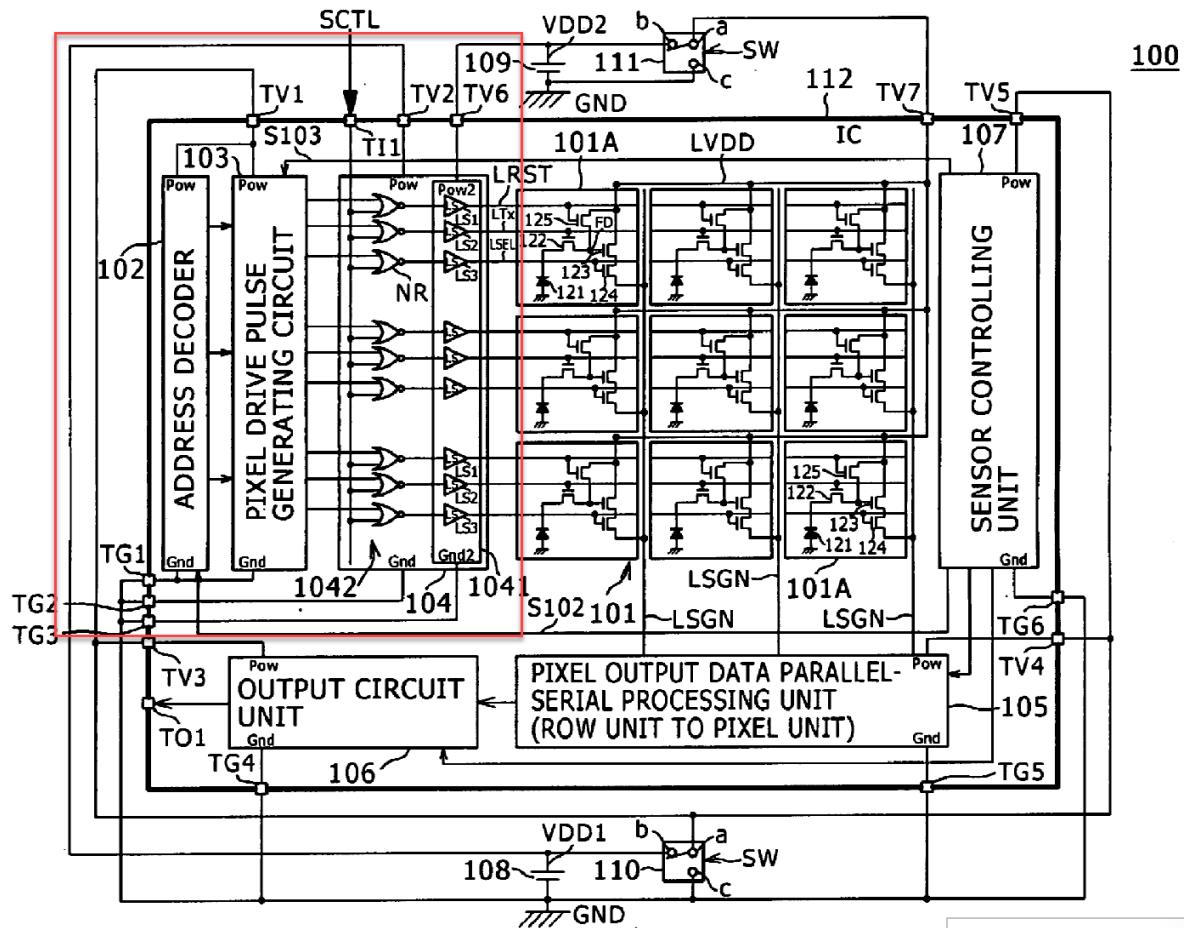

Insert: The following new Relationships with other classification places section.

Relationships with other classification places

If the document does not provide any specific details related to the row scanning/addressing circuits but rather functionally describes details of performing different sensor readout operations, then [H04N 5/341](#) only should be used for classification. Similarly, if the document specifies only functional details related to control of the exposure time, then [H04N 5/351](#) and/or [H04N 5/355](#) should be used for classification.

H04N 5/378

Insert: The following new Definition statement section.

Definition statement

This place covers:

- image sensor array readout circuits.

Readout circuits for CCD sensors arranged at the output of the sensor

CCD output stages like output buffers and source followers.

CCD output stages which are column parallel, i.e. provided for each column.

Readout circuits for CMOS sensors defining

Details related to the column readout lines and the circuits associated with them. Although the readout lines are placed in the sensor array, they are a functional part of the readout circuits.

These details are, for example, readout arrangements with:

- several column read out lines per column of pixels;
- column lines connectable by switches to perform analogue signal averaging/binning;
- multiple column lines are multiplexed to be processed by common processing means, like CDS, ADC, buffers;
- column lines connectable to different processing means (CDS, ADC, buffers) to randomize the column pattern noise;

DATE: JANUARY 1, 2021

PROJECT DP0219

- column lines randomly connectable to different processing means (CDS, ADC, buffers) to randomize the column pattern noise;
- a column line being shared for pixels in a row;
- several storage capacitors per column used for CDS, binning, multi frame storage, etc.;
- reset or clamping circuits connected to the column lines.

Details related to the load circuit, e. g. current source of the source follower and control thereof.

Details related to ADC circuits (ADC circuits as such - [H03M 1/12](#)) used in sensor array readout circuits.

These details are for example, related to:

- ADC type, like single slope, flash, SAR, sigma-delta, ADC combined with the gain of a programmable gain amplifier (ADC of this type as such [H03M 1/18](#));

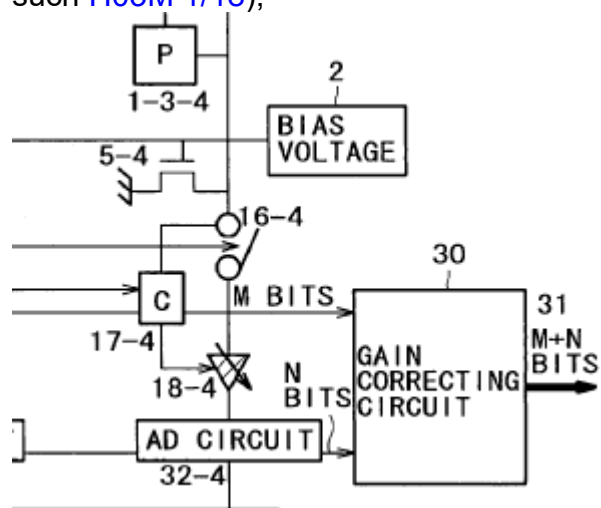

- ADC arrangement in the readout circuit;
- ADC arranged per-column or for group of columns;

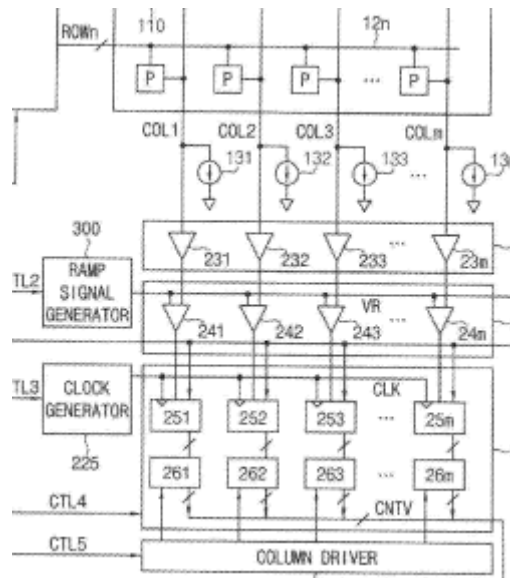

- ADC arranged at the output of the sensor;
- ADC ramp voltage generation - different slopes and directions, non-linear, ramp amplitude;
- processing implemented in the ADC, like CDS, binning.

Details related to output amplifiers:

- CTIA amplifiers (normally used in passive image sensors);
- amplifiers with controllable gain GCA, PGA;
- amplifiers arranged per-column or for group of columns;
- amplifiers arranged at the output of the sensor.

Details of arrangement of the CDS circuit as part of the readout circuit:

- CDS arranged per column;

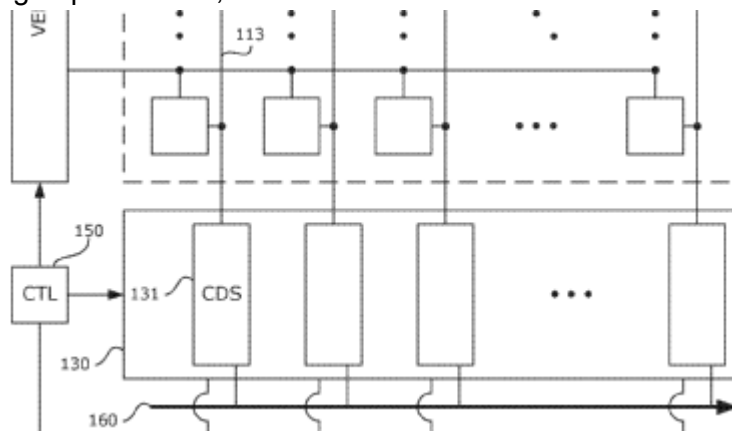

- CDS arranged at the output of the sensor.

CDS circuits as such are classified in [H04N 5/3575](#).