

## B65G

**TRANSPORT OR STORAGE DEVICES, e.g. CONVEYORS FOR LOADING OR TIPPING, SHOP CONVEYOR SYSTEMS OR PNEUMATIC TUBE CONVEYORS (packaging [B65B](#); handling thin or filamentary materials, e.g. paper sheets or thread, [B65H](#); cranes [B66C](#); portable mobile or lifting or hauling appliances, e.g. hoists, [B66D](#); devices for lifting or lowering goods for loading or unloading purposes, e.g. fork-lift trucks, [B66F 9/00](#); emptying bottles, jars, casks, barrels or similar containers, not otherwise provided for, [B67C 9/00](#); delivering or transferring liquids [B67D](#); filling or discharging vessels for liquefied, solidified or compressed gases [F17C](#); pipe-line systems for fluids [F17D](#))**

### Definition statement

*This place covers:*

Methods or devices for storage on an industrial or commercial scale of

- articles in warehouses or magazines
- bulk solid material or disorderly articles
- fluids in cavities or chambers in the earth

Devices, for example rollers or slings, for assisting manual moving or manipulation of heavy loads

Methods or apparatus for conveying articles or bulk solid material from one location to another, for example within an industrial plant,

- by gravity, for example in chutes
- by rollers, for example on driven or non-driven roller-ways
- on endless load-carrying surfaces, for example belts or chains, or an essentially endless series of individual load-carriers
- on jiggling surfaces
- by impellers, for example reciprocating scrapers, rotating fingers or elements carried by endless traction members
- by throwing
- by rotating or screw-like impellers
- by fluid flow or pressure, for example in tubes or by floating
- by electrostatic, electric or magnetic effects
- by other mechanical or non-mechanical means

Methods or devices for handling articles or materials in connection with conveyors, for example for feeding or discharging conveyors or for orientating articles on a conveyor

Conveying systems characterised by their application for specified purposes and not otherwise provided for, for example conveying workpieces through baths

Methods or devices for stacking or de-stacking of three-dimensional articles or loose materials in bulk

Methods or devices for loading or unloading of vehicles, large containers, ships and the like, for example in storage areas, marshalling yards or harbours

### Relationships with other classification places

Storage

This subclass is the general, function-oriented place for mechanical aspects of storage of the articles and materials stated in the definition statement above. Classification is made in this subclass if

## Relationships with other classification places

the method or apparatus is of general interest in the field of storing. This subclass does not cover modification or treatment of materials by storing, for example by drying or maturing.

If the method or apparatus is characterised by its adaptation to particular materials or articles (for example silage or parked cars) it is classified in the place for that adaptation, if such a place exists. For examples of application places, see the section "References relevant to classification in this subclass" below.

If subject matter is of interest both for its general function-oriented aspects and its application aspects, classification should be made both in this subclass and in the place for the application.

## Conveyors

This subclass is the general, function-oriented place for conveyors or similar transport devices. Such devices are incorporated in many different types of apparatus and industrial plants. Classification is made in this subclass if the method or apparatus is of general interest in the field of conveying, for example when it relates to the solution of a problem that is internal to a conveyor (for example a driving mechanism) or not primarily related to a particular process.

If the method or apparatus is characterised by its adaptation to a particular process (for example drying or heat treatment) or its incorporation in a particular apparatus (for example a root-crop harvester or a furnace), it is classified in the place for that process or apparatus, if such a place exists. For examples of application places, see the section "References relevant to classification in this subclass" below. This subclass does not cover processes in which articles or materials are modified or treated during conveying.

If subject matter is of interest both for its general function-oriented aspects and its application aspects, classification should be made both in this subclass and in the place for the application.

## Transport devices

This subclass essentially covers stationary or portable transportation devices, such as conveyors or conveying systems. It does not cover vehicles per se, which are covered by classes [B60](#) - [B64](#), or containers, trays or pallets, which are covered by [B65D](#). For more detailed references see the section "Informative references" below.

## Loading and unloading

This subclass covers loading and unloading of vehicles, ships and aircraft by means which are not incorporated in those vehicles. Loading by means which are incorporated in vehicles is covered by the places for the vehicles. For examples of such places see the section "References relevant to classification in this subclass" below.

## Filling and emptying

This subclass covers general, function-oriented aspects of filling and emptying of larger containers, such as bunkers or hoppers. Classification is made in this subclass if the method or apparatus is of general interest in the field.

If the method or apparatus is characterised by its adaptation to particular materials or processes (for example in forage silos or coke ovens) it is classified in the place for that adaptation, if such a place exists. For examples of application places, see the section "References relevant to classification in this subclass" below.

If subject matter is of interest both for its general function-oriented aspects and its application aspects, classification should be made both in this subclass and in the place for the application.

This subclass does not cover filling of packages or small containers, for example boxes or cans, which is covered by subclass [B65B](#).

## Relationships with other classification places

With the exception of manual tilting of barrels, which is covered by [B65G 65/24](#), this subclass does not cover emptying of small containers, for example cans or casks, which is covered by [B65B](#) and [B67C 9/00](#).

## References

### Limiting references

*This place does not cover:*

Packaging	<a href="#">B65B</a>
Handling thin or filamentary materials, e.g. paper sheets or thread	<a href="#">B65H</a>
Cranes	<a href="#">B66C</a>
Portable mobile or lifting or hauling appliances, e.g. hoists	<a href="#">B66D</a>
Devices for lifting or lowering goods for loading or unloading purposes, e.g. fork-lift trucks	<a href="#">B66F 9/00</a>
Emptying bottles, jars, casks, barrels or similar containers, not otherwise provided for	<a href="#">B67C 9/00</a>
Delivering or transferring liquids	<a href="#">B67D</a>
Filling or discharging vessels for liquefied, solidified or compressed gases	<a href="#">F17C</a>
Pipe-line systems for fluids	<a href="#">F17D</a>

### Application-oriented references

*Examples of places where the subject matter of this place is covered when specially adapted, used for a particular purpose, or incorporated in a larger system:*

Sowing or planting machines, manure loaders or distributors	<a href="#">A01C</a>
Conveyors for root crop harvesters	<a href="#">A01D 17/00</a> - <a href="#">A01D 33/00</a>
Conveyors for mowers, harvesters or combines	<a href="#">A01D 41/00</a> - <a href="#">A01D 61/00</a>
Loaders for hay or like field crops	<a href="#">A01D 87/00</a> - <a href="#">A01D 90/00</a>
Conveyors for threshing machines, baling presses or cutting apparatus for hay or straw	<a href="#">A01F</a>
Storing agricultural or horticultural produce	<a href="#">A01F 25/00</a>
Hydroponic culture on conveyors	<a href="#">A01G 31/04</a>
Baking ovens with moving baking surfaces	<a href="#">A21B 1/42</a>
Dough handling	<a href="#">A21C 9/00</a>
Processing meat, poultry or fish	<a href="#">A22C</a>
Pasteurising of food in moving packages	<a href="#">A23L 3/02</a>
Conveyors for cigar- or cigarette-making	<a href="#">A24C 5/35</a>
Conveyors for shoemaking	<a href="#">A43D 117/00</a>
Luggage carriers	<a href="#">A45C 13/38</a>
Storing agricultural or horticultural produce	<a href="#">A45F 5/00</a>
Food-conveying devices for tables	<a href="#">A47G 23/08</a>
Dish-washing machines with conveyors	<a href="#">A47L 15/24</a>
Chutes for amusement purposes, Helter-skelters	<a href="#">A63G 21/00</a>
Filtering	<a href="#">B01D</a>

## Application-oriented references

Granulating on conveyor belts	<a href="#">B01J 2/26</a>
Feeding devices for crushing or disintegrating machines	<a href="#">B02C 23/02</a>
Separating solid materials	<a href="#">B03B</a>
Magnetic separation with material carriers in the form of belts	<a href="#">B03C 1/16</a>
Sieving, screening, sifting, or sorting solid materials	<a href="#">B07B</a>
Sorting of mail or documents	<a href="#">B07C</a>
Cleaning of containers on conveyors	<a href="#">B08B 9/20</a>
Arrangement of feeding rollers in metal-rolling mills	<a href="#">B21B 39/10</a>
Handling work in processing of metal tubes or profiles	<a href="#">B21D 43/00</a>
Handling work in connection with machine tools	<a href="#">B23Q 7/00</a> , <a href="#">B23Q 41/02</a>
Handling logs or timber in saw mills	<a href="#">B27B 31/00</a>
Transporting material in manufacture of fibre boards	<a href="#">B27N 3/16</a>
Handling material in production of ceramic articles	<a href="#">B28B 5/00</a> , <a href="#">B28B 13/00</a>
Mixing concrete on or by conveyors	<a href="#">B28C 5/34</a>
Handling material in shaping or joining of plastics	<a href="#">B29C 31/00</a>
Conveying between operating stations in book-making machines	<a href="#">B42C 19/08</a>
Conveyors for unloading of vehicles	<a href="#">B60P 1/36</a> , <a href="#">B60P 1/40</a>
Air-cushion vehicles	<a href="#">B60V</a>
Handcarts, sledges, features of hand-propelled wheeled devices or pedestrian-controlled, power-driven vehicles equally applicable to handcarts	<a href="#">B62B</a>
Conveyor systems for motor vehicle or trailer assembly lines	<a href="#">B62D 65/18</a>
Arrangement of conveyors for loading of ships	<a href="#">B63B 27/22</a>
Supplying, feeding, arranging, or orientating articles to be packaged	<a href="#">B65B 35/00</a>
Supplying or feeding fluent-solid material or loose masses of small articles to be packaged	<a href="#">B65B 37/00</a>
Feeding containers in association with packaging	<a href="#">B65B 43/00</a>
Gathering or removal of refuse	<a href="#">B65F</a>
Transferring of refuse between vehicles or containers	<a href="#">B65F 9/00</a>
Elevators for buildings, mines or similar structures	<a href="#">B66B 1/00</a> - <a href="#">B66B 20/00</a>
Escalators or moving walkways	<a href="#">B66B 21/00</a> - <a href="#">B66B 29/00</a>
Transporting glass during manufacture	<a href="#">C03B 35/00</a>
Coke-ovens with conveying means	<a href="#">C10B 7/00</a> , <a href="#">C10B 39/12</a> , <a href="#">C10B 47/32</a>
Charging or discharging coke ovens	<a href="#">C10B 31/00</a> , <a href="#">C10B 33/00</a>
Conveying textile fibres between machines	<a href="#">D01G 23/00</a>
Drying cabinets or chambers with conveying means	<a href="#">D06F 58/12</a>
Dredging or soil-shifting	<a href="#">E02F</a>
Chutes in buildings for transporting refuse	<a href="#">E04F 17/12</a>
Conveying building materials or building elements	<a href="#">E04G 21/00</a>
Garages with mechanical means for shifting or lifting vehicles	<a href="#">E04H 6/14</a>



## Application-oriented references

Removal of material in open-pit mines	<a href="#">E21C 47/00</a>
Transport specially adapted for underground conditions	<a href="#">E21F 13/00</a>
Fuel-feeding grates for combustion chambers	<a href="#">F23H</a>
Removing ash, clinker, or slag from combustion chambers	<a href="#">F23J 1/00</a>
Feeding solid fuel to combustion apparatus	<a href="#">F23K 3/00</a>
Conveyors in freezing or cooling apparatus or cold rooms	<a href="#">F25D 3/11</a> , <a href="#">F25D 13/06</a> , <a href="#">F25D 25/00</a>
Drying objects with progressive movement	<a href="#">F26B 15/00</a>
Furnaces through which the charge is moved mechanically	<a href="#">F27B 9/00</a>
Charging, discharging or manipulating charge in ovens	<a href="#">F27D 3/00</a>
Feeding of ammunition	<a href="#">F41A 9/00</a>
Weighing apparatus using conveyors	<a href="#">G01G 11/00</a> , <a href="#">G01G 13/00</a>
Conveying record carriers	<a href="#">G06K 13/00</a>
Counting of objects carried by a conveyor	<a href="#">G06M 7/00</a>
Coin-free apparatus dispensing articles from movable containers	<a href="#">G07F 11/46</a>
Arrangements for handling fuel or other materials which are used in nuclear reactors	<a href="#">G21C 19/00</a>
Handling semiconductor devices during manufacture or treatment	<a href="#">H01L 21/67</a>
Feeding of components in manufacturing of electric components	<a href="#">H05K 13/02</a>

**Informative references**

Attention is drawn to the following places, which may be of interest for search:

Manipulators	<a href="#">B25J</a>
Producing conveyor belts	<a href="#">B29D 29/06</a>
Vehicles adapted for load transportation	<a href="#">B60P</a>
Railway wagons adapted for load transportation	<a href="#">B61D</a>
Hand carts	<a href="#">B62B</a>
Superstructures for load-carrying vehicles	<a href="#">B62D 33/00</a>
Loading or load-accommodating arrangements for ships or vessels	<a href="#">B63B 25/00</a> , <a href="#">B63B 27/00</a>
Equipment for handling freight in aircraft	<a href="#">B64D 9/00</a>
Containers, pallets	<a href="#">B66B 21/00</a>
Hoisting, lifting, hauling or pushing not otherwise provided for, e.g. jacks	<a href="#">B66F</a>
Construction of bulk storage containers employing civil engineering techniques	<a href="#">E04H 7/00</a>
Pumps for fluids	<a href="#">F04D</a>
Control of flow in general	<a href="#">G05D 7/00</a>
Control of level in general	<a href="#">G05D 9/00</a>
Holding or levitation devices using magnetic attraction or repulsion	<a href="#">H02N 15/00</a>

## B65G 1/00

Storing articles, individually or in orderly arrangement, in warehouses or magazines (conveyor combinations in warehouses, magazines or workshops [B65G 37/00](#); stacking of articles [B65G 57/00](#); removing articles from stacks [B65G 59/00](#); loading machines [B65G 65/02](#))

### References

#### Limiting references

*This place does not cover:*

Conveyor combinations in warehouses, magazines, or workshops	<a href="#">B65G 37/00</a>
Stacking of articles	<a href="#">B65G 57/00</a>
Removing articles from stacks	<a href="#">B65G 59/00</a>
Loading machines	<a href="#">B65G 65/02</a>

#### Informative references

*Attention is drawn to the following places, which may be of interest for search:*

Arrangements of articles for drying or baking in kilns or ovens	<a href="#">F26</a> , <a href="#">F27</a>
Controlling the size of articles to be stored before storage (measuring arrangements),	<a href="#">G01B 11/00</a>
Controlling the size of articles to be stored before storage (measuring contours),	<a href="#">G01B 11/24</a>
Controlling the size of articles to be stored before storage (measuring the length or width)	<a href="#">G01B 21/06</a>
Controlling the size of articles to be stored before storage (measuring the volume)	<a href="#">G01F 17/00</a>
Controlling the size of articles to be stored before storage, (optical means, light barriers)	<a href="#">G01V 8/00</a>
Analogue computers	<a href="#">G06G</a>
Coin-freed dispensing apparatus	<a href="#">G07F 11/00</a>

**B65G 1/02****Storage devices (furniture [A47B](#); shop fittings [A47F](#))****Definition statement***This place covers:*

Illustrative example of subject matter classified in this group:

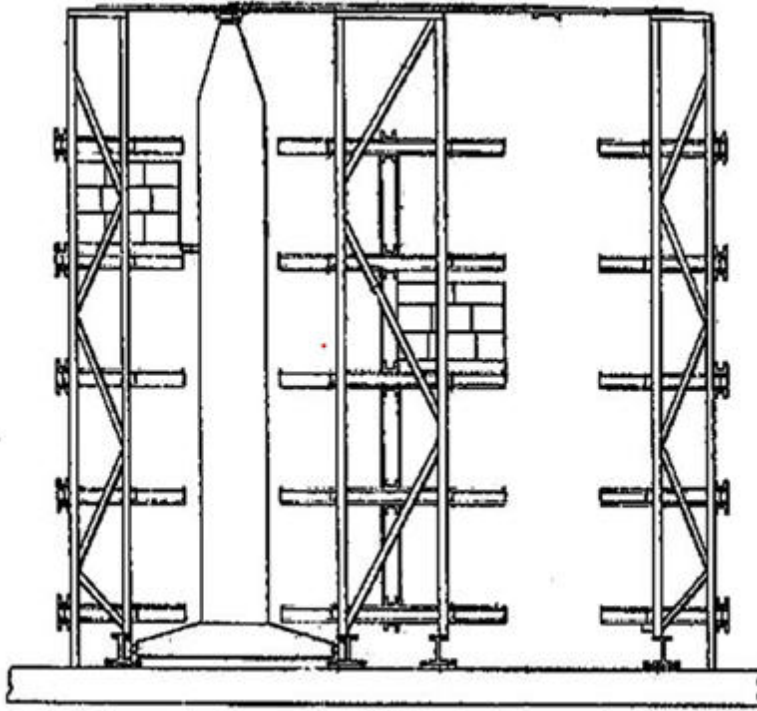
**References****Limiting references***This place does not cover:*

Furniture	<a href="#">A47B</a>
Shop fittings	<a href="#">A47F</a>

**Application-oriented references***Examples of places where the subject matter of this place is covered when specially adapted, used for a particular purpose, or incorporated in a larger system:*

Mechanical garages	<a href="#">E04H</a>
For data record cards in association with machines for marking or sensing data	<a href="#">G06K</a>
Coin-freed apparatus	<a href="#">G07F</a>

**Informative references**

Attention is drawn to the following places, which may be of interest for search:

For elongated articles	<a href="#">B65G 1/0442</a>
Safety and protecting devices, e.g. against earthquake, collisions (fences, safety net, ...)	<a href="#">B65G 2207/20</a> , <a href="#">B65G 2207/40</a>
For particular type of storing, e.g. cheese storage	<a href="#">A01J 25/162</a>
Rack/shelf	<a href="#">A47B 47/021</a>
Connection to the ground	<a href="#">A47B 91/00</a>
Protecting rims, buffers	<a href="#">A47B 95/043</a>
Table equipment	<a href="#">A47G</a>
Pallets	<a href="#">B65D 19/00</a>
Rail construction on the floor (for stacker crane)	<a href="#">E01B</a>
Protection of shelves against forklift accident	<a href="#">E01F 15/141</a>
Coin changers or sorters	<a href="#">G07D</a>

**B65G 1/023**

{Arrangements of article supporting rollers on racks}

**Definition statement**

This place covers:

Illustrative example of subject matter classified in this group:

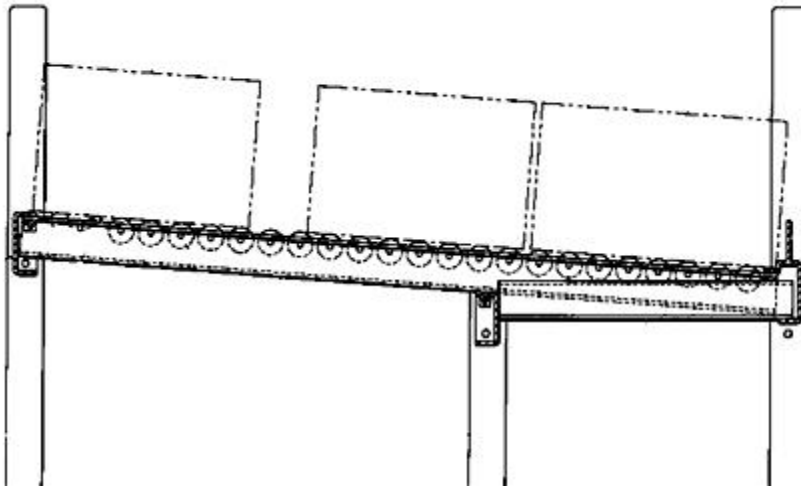
**References****Informative references**

Attention is drawn to the following places, which may be of interest for search:

Roller-ways	<a href="#">B65G 13/00</a>
Roller frames	<a href="#">B65G 13/11</a>
Arrangements of rollers mounted on framework	<a href="#">B65G 39/12</a>

## B65G 1/026

{Racks equipped with a displaceable load carrying surface to facilitate loading or unloading}

### Definition statement

*This place covers:*

Only the supporting surface moves

Illustrative example of subject matter classified in this group:

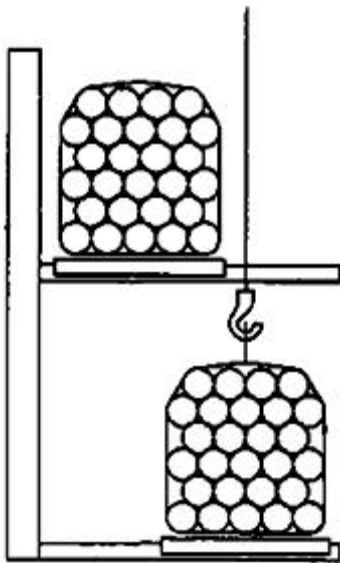

### References

#### Limiting references

*This place does not cover:*

For movable supporting surface (movable shelves)	<a href="#">B65G 1/10</a>
--------------------------------------------------	---------------------------

## B65G 1/04

mechanical

### Definition statement

*This place covers:*

It is the head group of mechanical devices used in conjunction with racks in order to charge, discharge the racks, provided these are not stacker cranes. This group also involves lifts, conveyor platforms (moving vertically) in form of racks.

Illustrative example of subject matter classified in this group:

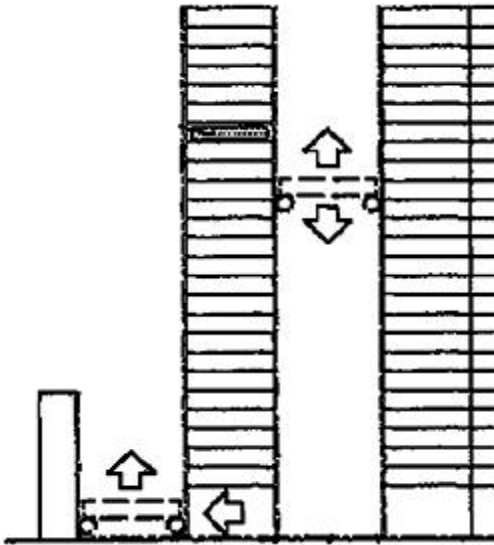

## References

### Informative references

Attention is drawn to the following places, which may be of interest for search:

Vertically or horizontally movable racks	<a href="#">B65G 1/127</a> , <a href="#">B65G 1/133</a>
Control of position of vehicles	<a href="#">G05D 1/00</a>

## **B65G 1/0407**

{using stacker cranes (constructional features of stacker cranes [B66F 9/06](#))}

### Definition statement

*This place covers:*

Only for Stacker cranes movable along the shelves

Illustrative example of subject matter classified in this group:

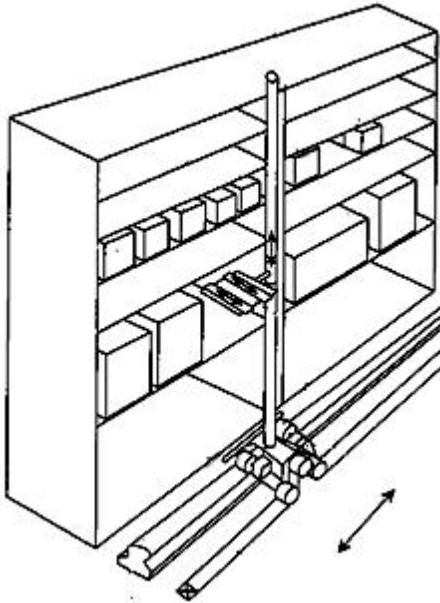

## References

### Limiting references

*This place does not cover:*

Stacker lifts	<a href="#">B65G 1/04</a>
---------------	---------------------------

### Informative references

*Attention is drawn to the following places, which may be of interest for search:*

Automatically guided forklift trucks	<a href="#">B66F 9/063</a>
--------------------------------------	----------------------------

## **B65G 1/0414**

**{provided with satellite cars adapted to travel in storage racks}**

### Definition statement

*This place covers:*

Satellite cars "controlled" by a stacker crane



Illustrative example of subject matter classified in this group:

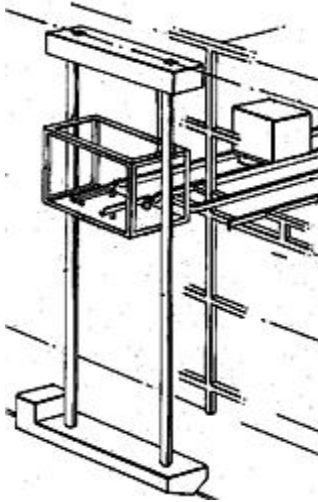

## References

### Informative references

Attention is drawn to the following places, which may be of interest for search:

with cars adapted to travel in storage aisles	<a href="#">B65G 1/0492</a>
with self propelled cars	<a href="#">B65G 1/065</a>

## B65G 1/0421

{with control for stacker crane operations}

### Definition statement

This place covers:

Illustrative example of subject matter classified in this group:

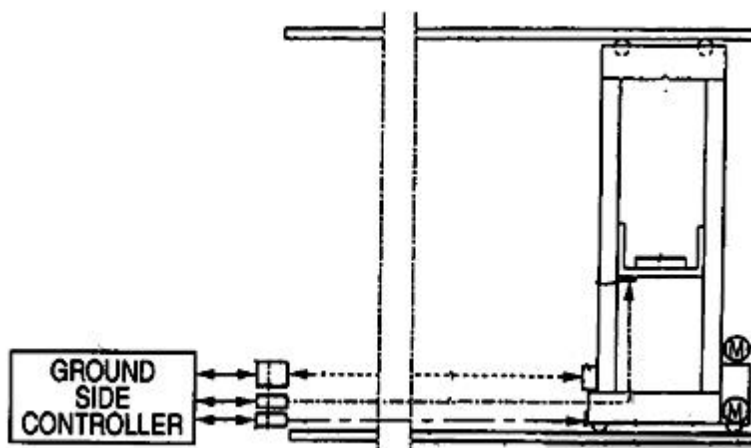

## B65G 1/0428

{Transfer means for the stacker crane between the alleys}

### Definition statement

*This place covers:*

Illustrative example of subject matter classified in this group:

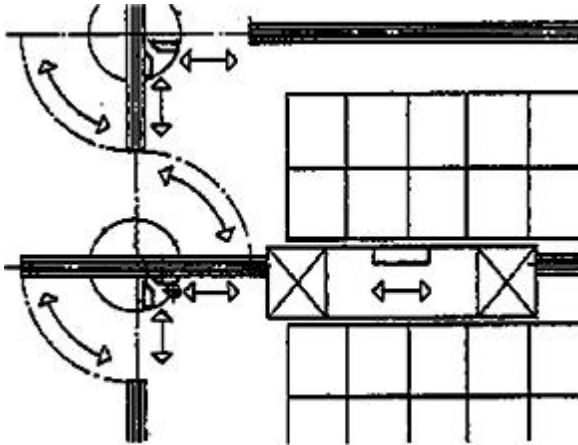

## B65G 1/0435

{with pulling or pushing means on either stacking crane or stacking area}

### Definition statement

*This place covers:*

Illustrative example of subject matter classified in this group:

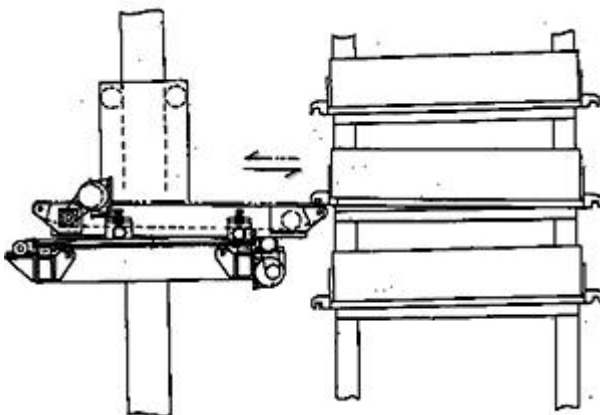

**B65G 1/0442**

{for elongated articles (drill pipe racking [E21B 19/14](#))}

**Definition statement**

*This place covers:*

Illustrative example of subject matter classified in this group:

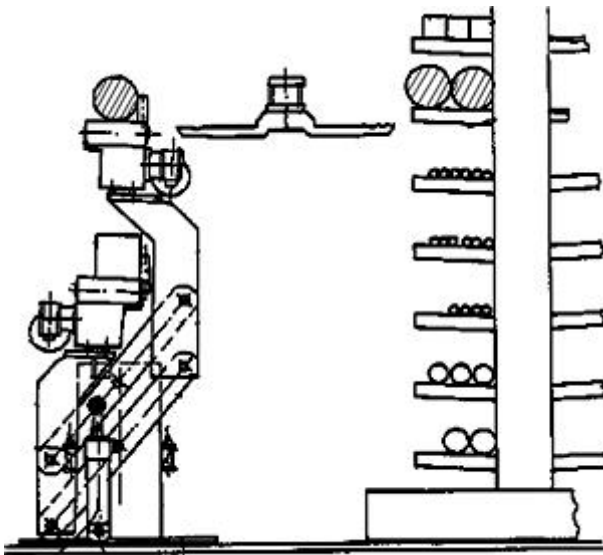
**References****Limiting references**

*This place does not cover:*

Storing articles, the articles being fed by gravity	<a href="#">B65G 1/08</a>
-----------------------------------------------------	---------------------------

**Informative references**

*Attention is drawn to the following places, which may be of interest for search:*

Broaching tools	<a href="#">B23D 43/00</a>
Hoisting, lifting, hauling or pushing	<a href="#">B66F</a>

## B65G 1/045

{in a circular arrangement, e.g. towers}

### Definition statement

*This place covers:*

Illustrative example of subject matter classified in this group:

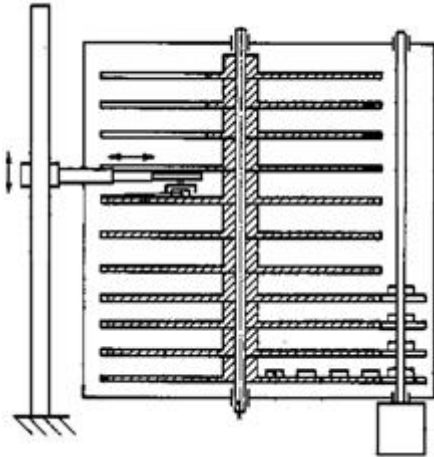

## B65G 1/0457

{with suspended load carriers}

### Definition statement

*This place covers:*

Illustrative example of subject matter classified in this group:

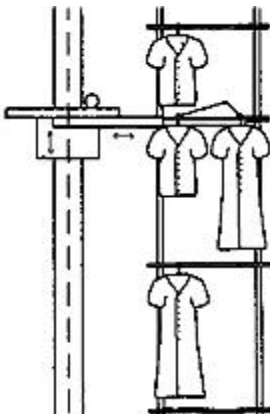

**B65G 1/0464****{with access from above}****Definition statement***This place covers:*

Illustrative example of subject matter classified in this group:

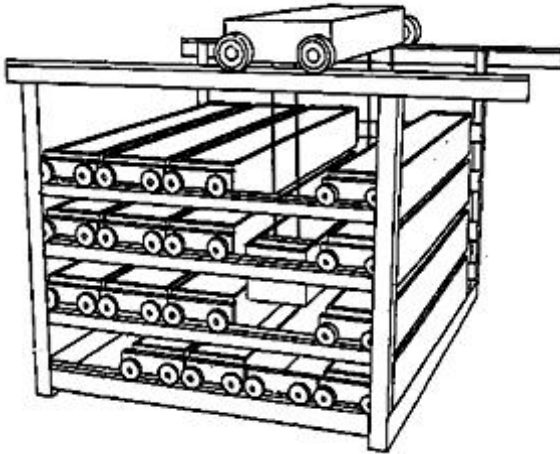
**References****Limiting references***This place does not cover:*

When the articles stored above have to be moved away for access	<a href="#">B65G 1/026</a>
-----------------------------------------------------------------	----------------------------

**B65G 1/0471****{with access from beneath}****Definition statement***This place covers:*

Illustrative example of subject matter classified in this group:

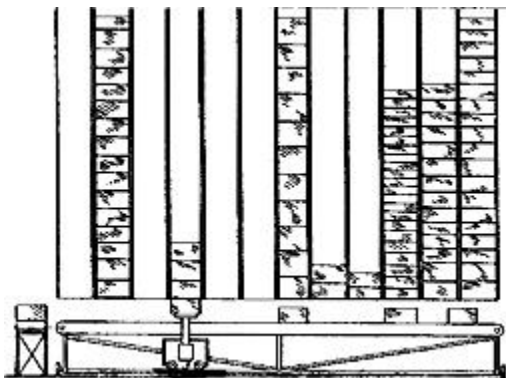

**B65G 1/0478****{for matrix-arrangements}****Definition statement***This place covers:*

Illustrative example of subject matter classified in this group:

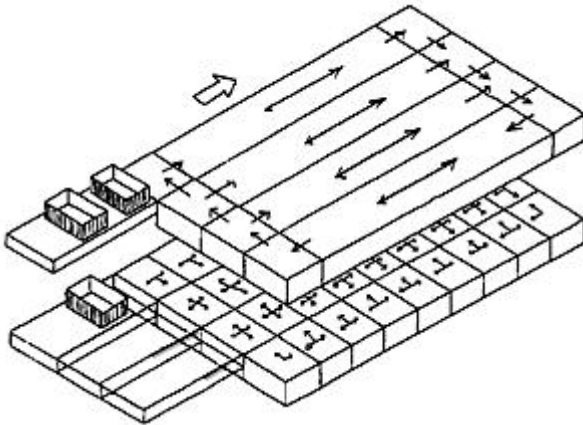
**B65G 1/0485****{Check-in, check-out devices}****Definition statement***This place covers:*

Illustrative example of subject matter classified in this group:

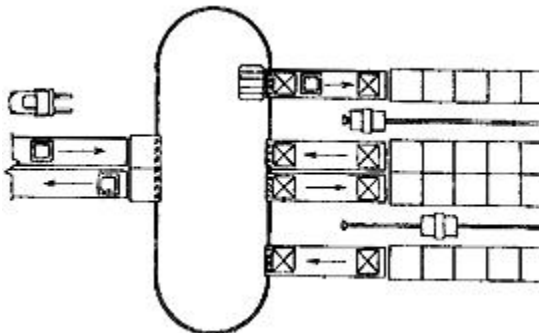
**B65G 1/0492****{with cars adapted to travel in storage aisles}****Definition statement***This place covers:*

When independently controlled (not controlled by a stacker crane)

Illustrative example of subject matter classified in this group:

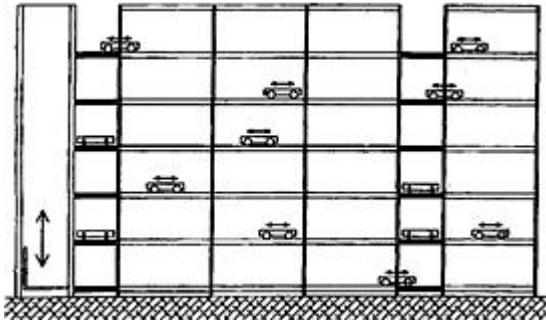

## B65G 1/06

with means for presenting articles for removal at predetermined position or level ([B65G 1/12](#) takes precedence)

### Definition statement

*This place covers:*

Illustrative example of subject matter classified in this group:

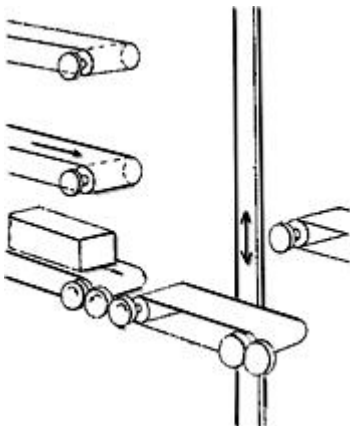

### References

#### Limiting references

*This place does not cover:*

Article supports or holders	<a href="#">B65G 1/12</a>
-----------------------------	---------------------------

## B65G 1/065

{with self propelled cars}

### Definition statement

*This place covers:*

When the car is ONLY moving in a SINGLE storage shelf.



Illustrative example of subject matter classified in this group:

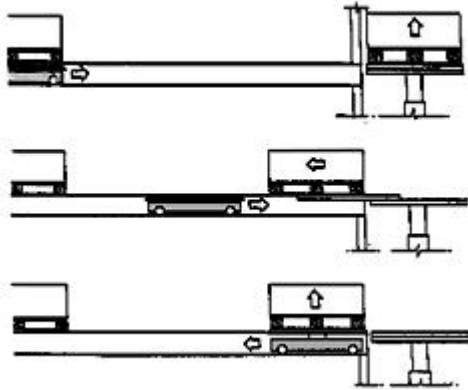

## References

### Informative references

Attention is drawn to the following places, which may be of interest for search:

Using stacker cranes	<a href="#">B65G 1/0407</a>
With cars adapted to travel in storage aisles	<a href="#">B65G 1/0492</a>

## B65G 1/07

the upper article of a pile being always presented at the same predetermined level

### Definition statement

This place covers:

Illustrative example of subject matter classified in this group:

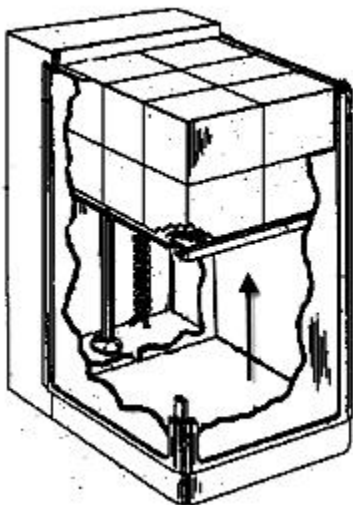

## References

### Informative references

Attention is drawn to the following places, which may be of interest for search:

Racks	<a href="#">A47F 1/06</a>
Hand carts	<a href="#">B62B 3/00</a>
Containers with a movable bottom	<a href="#">B65D 83/0005</a>

## B65G 1/08

the articles being fed by gravity {(braking arrangements for roller-ways [B65G 13/075](#); separating or stopping elements [B65G 47/88](#))}

### Definition statement

*This place covers:*

Illustrative example of subject matter classified in this group:

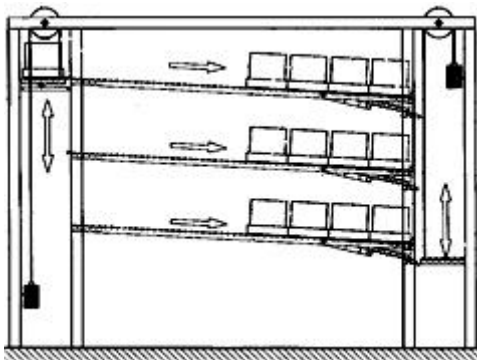

## B65G 1/10

with relatively movable racks to facilitate insertion or removal of articles {(cabinets with means for moving compartments up and down [A47B 51/00](#); cabinet system, e.g. consisting of cabinets arranged in a row with means to open or close passages between adjacent cabinets [A47B 53/02](#))}

### Definition statement

*This place covers:*

Racks movable for the passage of the crane

Illustrative example of subject matter classified in this group:

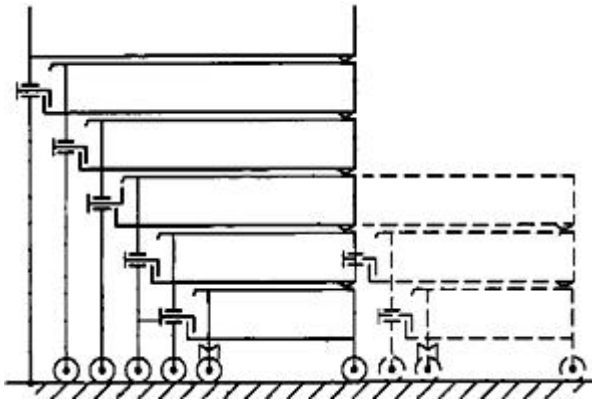

**References**

**Limiting references**

*This place does not cover:*

Cabinets with means for moving compartments up and down	<a href="#">A47B 51/00</a>
Cabinets arranged in a row with means to open or close passages between adjacent cabinets	<a href="#">A47B 53/02</a>

**Informative references**

*Attention is drawn to the following places, which may be of interest for search:*

Bringing articles in front of the shelf	<a href="#">A47F 1/12</a>
-----------------------------------------	---------------------------

**B65G 1/12**

**with {separate} article supports or holders movable in a closed circuit to facilitate insertion or removal of articles {the articles being books, documents, forms or the like}**

**Definition statement**

*This place covers:*

Illustrative example of subject matter classified in this group:

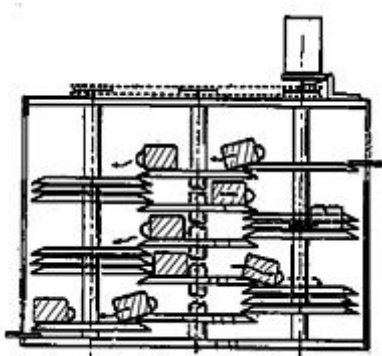

## References

### *Informative references*

*Attention is drawn to the following places, which may be of interest for search:*

Storage devices for data carriers	<a href="#">G11B 17/00</a>
-----------------------------------	----------------------------

## B65G 1/127

**the circuit being confined in a vertical plane**

### Definition statement

*This place covers:*

Illustrative example of subject matter classified in this group:

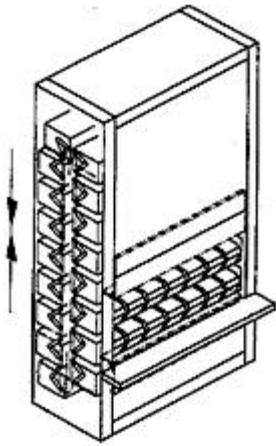

## B65G 1/133

the circuit being confined in a horizontal plane

### Definition statement

*This place covers:*

Illustrative example of subject matter classified in this group:

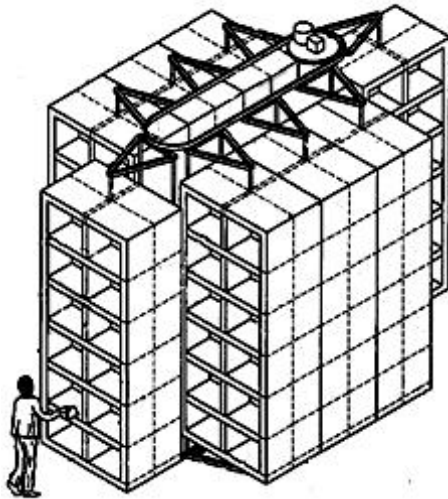

## B65G 1/137

with arrangements or automatic control means for selecting which articles are to be removed

### Definition statement

*This place covers:*

Illustrative example of subject matter classified in this group:

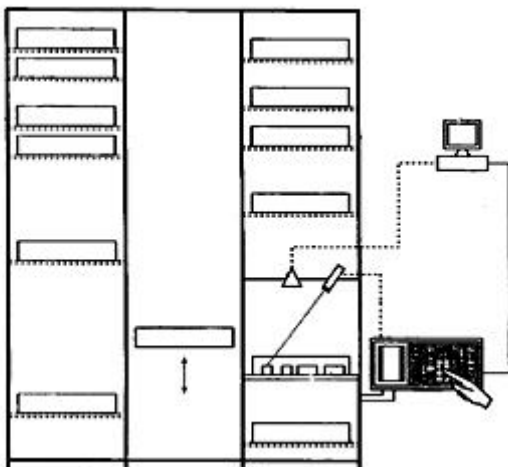

## References

### Application-oriented references

Examples of places where the subject matter of this place is covered when specially adapted, used for a particular purpose, or incorporated in a larger system:

Devices for feeding articles to conveyors from several groups of articles	<a href="#">B65G 47/04</a>
---------------------------------------------------------------------------	----------------------------

### Informative references

Attention is drawn to the following places, which may be of interest for search:

For fulfilling orders in warehouses	<a href="#">B65G 1/1373</a>
-------------------------------------	-----------------------------

## B65G 1/1371

{with data records}

### Definition statement

*This place covers:*

Record of data related to articles

Illustrative example of subject matter classified in this group:

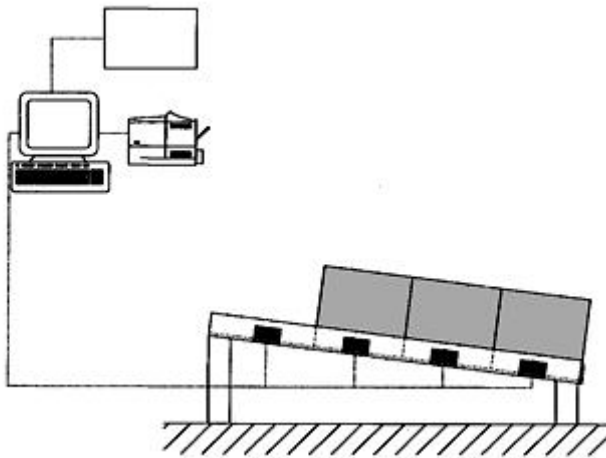

## References

### Informative references

Attention is drawn to the following places, which may be of interest for search:

Casings, enclosures or frames for labels	<a href="#">G09F 3/18</a>
------------------------------------------	---------------------------

**B65G 1/1373****{for fulfilling orders in warehouses}****Definition statement***This place covers:*

Illustrative example of subject matter classified in this group:

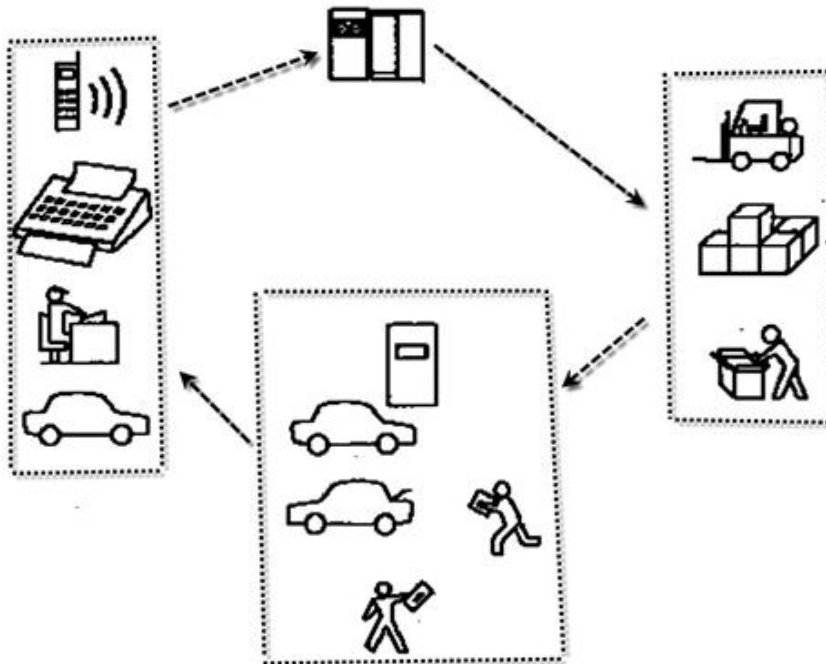
**References****Informative references***Attention is drawn to the following places, which may be of interest for search:*

Food conveying devices in restaurants	<a href="#">A47F 10/06</a>
Medicaments	<a href="#">A61J 7/00</a>
Recognition of data, handling record carriers	<a href="#">G06K 15/00</a>
Logistic, for following the transport path of the articles	<a href="#">G06Q 10/08</a>



## **B65G 1/1375**

**{the orders being assembled on a commissioning stacker-crane or truck}**

### **Definition statement**

*This place covers:*

Illustrative example of subject matter classified in this group:



## **B65G 1/1376**

**{the orders being assembled on a commissioning conveyor}**

### **Definition statement**

*This place covers:*

Illustrative example of subject matter classified in this group:

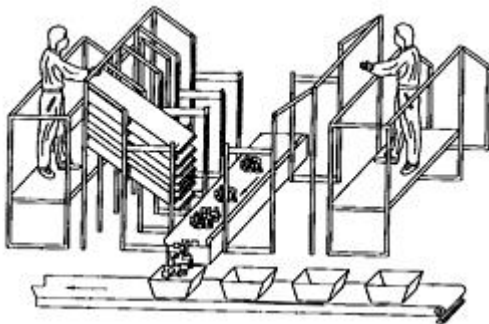

**B65G 1/1378**

{the orders being assembled on fixed commissioning areas remote from the storage areas}

**Definition statement**

*This place covers:*

Illustrative example of subject matter classified in this group:

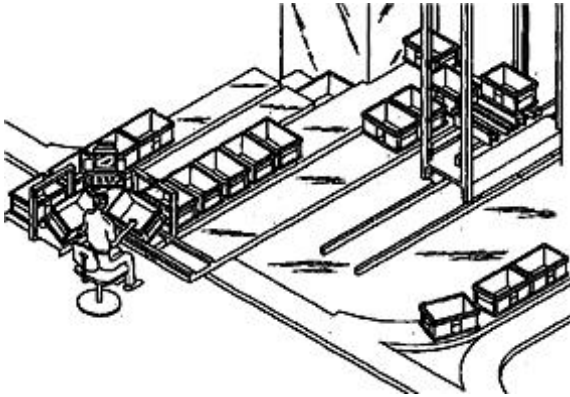
**B65G 1/14**

**Stack holders or separators**

**Definition statement**

*This place covers:*

Illustrative example of subject matter classified in this group:

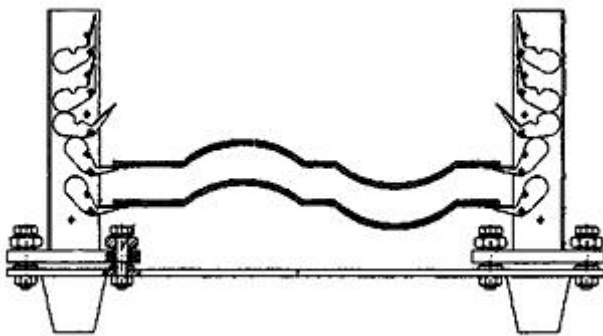
**References****Informative references**

*Attention is drawn to the following places, which may be of interest for search:*

For vehicles	<a href="#">B65D</a> , <a href="#">B65D 19/44</a> , <a href="#">B65D 90/004</a> , <a href="#">B65D 85/68</a>
Vehicle parts	<a href="#">B65D 2585/6882</a>

## B65G 1/16

### Special arrangements of articles in storage spaces

#### Definition statement

*This place covers:*

Illustrative example of subject matter classified in this group:

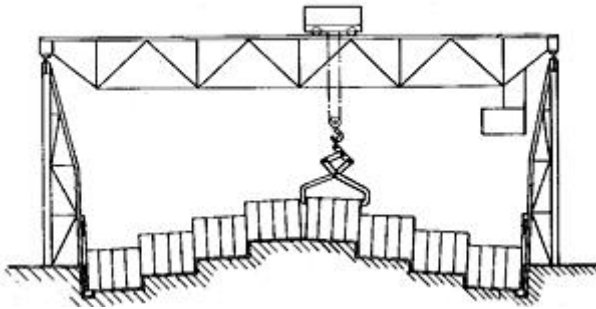

## B65G 1/18

### Articles inclined so as to be mutually self-supporting

#### Definition statement

*This place covers:*

Illustrative example of subject matter classified in this group:

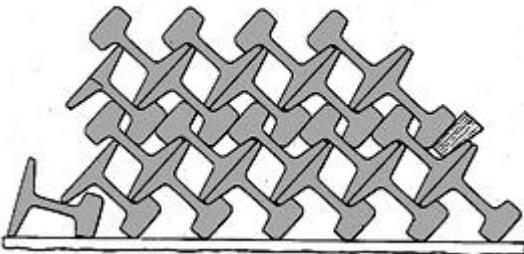

**B65G 1/20****Articles arranged in layers with spaces between articles****Definition statement**

*This place covers:*

Illustrative example of subject matter classified in this group:

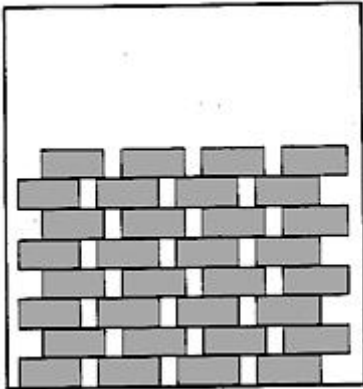
**B65G 3/00**

**Storing bulk material or loose, i.e. disorderly, articles (filling or emptying storage spaces or containers, spreading-out or piling-up bulk material or loose articles [B65G 65/28](#), [B65G 65/30](#), [B65G 69/04](#))**

**References****Limiting references**

*This place does not cover:*

Filling or emptying storage spaces or containers, spreading-out or piling-up bulk material or loose articles	<a href="#">B65G 65/28</a> , <a href="#">B65G 65/30</a> , <a href="#">B65G 69/04</a>
--------------------------------------------------------------------------------------------------------------	-----------------------------------------------------------------------------------------

**Informative references**

*Attention is drawn to the following places, which may be of interest for search:*

Transferring or trans-shipping at storage areas, railway yards or harbours; Marshalling yard installations	<a href="#">B65G 63/00</a>
Storing agricultural or horticultural produce	<a href="#">A01F 25/00</a>
Additives to prevent inflammation of the bulk material	<a href="#">C09K 15/00</a> , <a href="#">C09K 21/00</a>
Anti-oxidant compositions; Compositions inhibiting chemical change	<a href="#">C09K 15/00</a>
Fireproofing materials	<a href="#">C09K 21/00</a>
Solid fuels	<a href="#">C10L 5/00</a>

**B65G 3/02**

in the open air ([B65G 3/04](#) takes precedence)

**Definition statement**

*This place covers:*

Illustrative example of subject matter classified in this group:

**References****Limiting references**

*This place does not cover:*

In bunkers, hoppers, or like containers	<a href="#">B65G 3/04</a>
-----------------------------------------	---------------------------

**Informative references**

*Attention is drawn to the following places, which may be of interest for search:*

Covering for agricultural produce	<a href="#">A01F 25/16</a>
Covering of dumping sites	<a href="#">B09B 1/004</a>
Biodegradable film	<a href="#">C09K 3/00</a>
When the cavity or chamber is lined, documents	<a href="#">F17C 3/005</a>

**B65G 3/04****in bunkers, hoppers, or like containers****Definition statement***This place covers:*

Illustrative example of subject matter classified in this group:

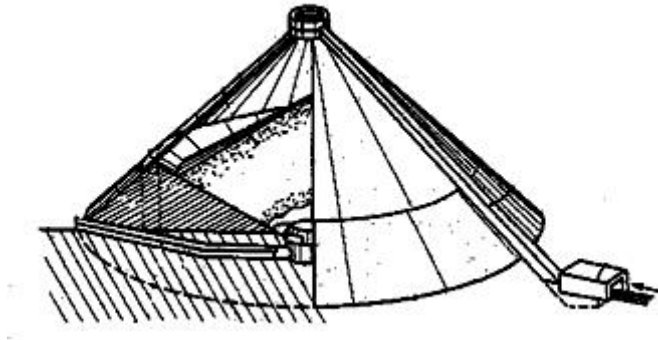
**References****Informative references***Attention is drawn to the following places, which may be of interest for search:*

"Big" storage containers	<a href="#">B65D 88/00</a> , <a href="#">B65D 90/00</a> and <a href="#">E04H 7/00</a>
Vessels containing liquified gases	<a href="#">F17C</a>

**B65G 5/00****Storing fluids in natural or artificial cavities or chambers in the earth****Definition statement***This place covers:*

Illustrative example of subject matter classified in this group:

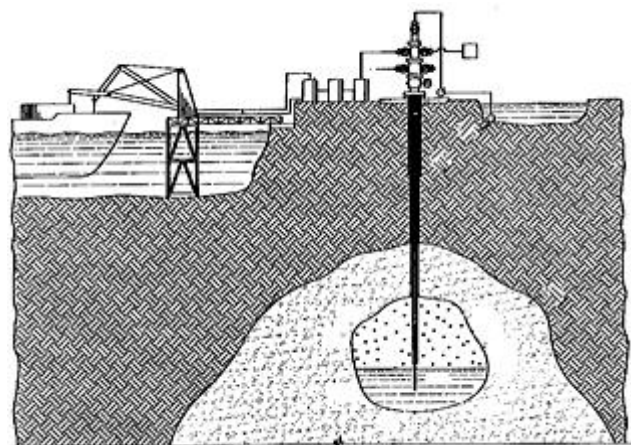

## References

### Informative references

Attention is drawn to the following places, which may be of interest for search:

Dumping solid waste	<a href="#">B09B 1/00</a>
Treatment of carbon dioxide for sequestration	<a href="#">C01B 2203/86</a>
Treatment of waste water, sewage or sludge	<a href="#">C02F</a>
Treatment of metallic scrap	<a href="#">C22B 7/00</a>
Carbon dioxide sequestration	<a href="#">E21B 41/0064</a>
Modification of mine passages or chambers for storage purposes, especially for fluids	<a href="#">E21F 17/16</a>
Storing compressed air for electricity production by a turbine or when a turbine compresses the air prior to storage	<a href="#">F02C 6/16</a>
Gas-holders of variable capacity	<a href="#">F17B</a>
Underground vessel for containing liquefied gas	<a href="#">F17C 1/007</a>
Underground vessel not under pressure	<a href="#">F17C 3/005</a>

## B65G 5/005

{in porous layers}

### Definition statement

*This place covers:*

Type of layers and surrounding layers

Methods and devices to fill the porous layers

Illustrative example of subject matter classified in this group:

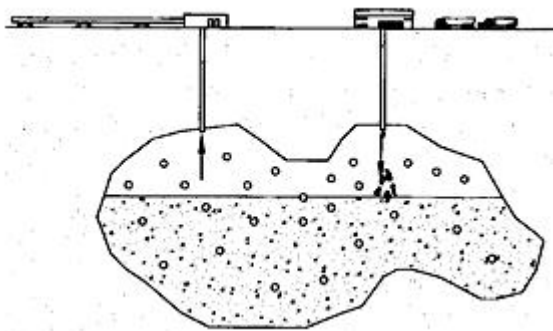

## References

### Informative references

Attention is drawn to the following places, which may be of interest for search:

Pattern of wells	<a href="#">E21B 43/00</a>
Production of coal-bed methane	<a href="#">E21B 43/006</a>



## B65G 7/00

Devices for assisting manual moving or tilting heavy loads (roller-ways [B65G 13/00](#); for tilting and emptying barrels or casks [B65G 65/24](#))

### Definition statement

*This place covers:*

Illustrative example of subject matter classified in this group:



### References

#### Limiting references

*This place does not cover:*

Roller-ways	<a href="#">B65G 13/00</a>
For tilting and emptying barrels or casks	<a href="#">B65G 65/24</a>

#### Informative references

*Attention is drawn to the following places, which may be of interest for search:*

Chutes	<a href="#">B65G 11/00</a>
Transport for special purposes	<a href="#">B65G 2813/00</a>
For bales, boxes or the like, by using pointed means	<a href="#">B65G 2813/026</a>

## B65G 7/02

Devices adapted to be interposed between loads and the ground or floor, e.g. crowbars with means for assisting conveyance of loads

### Definition statement

*This place covers:*

Illustrative example of subject matter classified in this group:

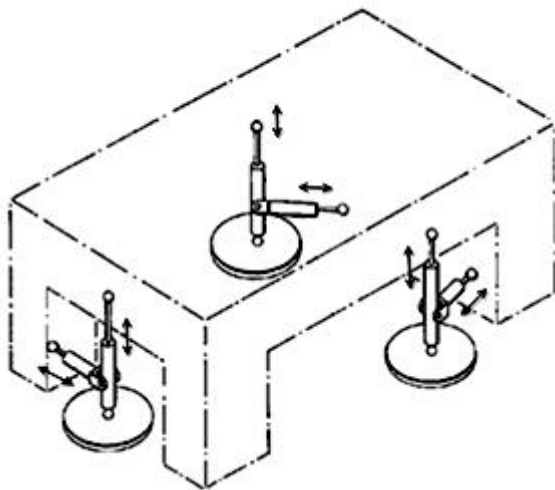

### References

#### Informative references

Attention is drawn to the following places, which may be of interest for search:

Handcarts	<a href="#">B62B 5/02</a>
Sledges	<a href="#">B62B 13/00</a>
Lift jacks	<a href="#">B66F 3/00</a>
Crowbars in general	<a href="#">B66F 15/00</a>

## B65G 7/04

### Rollers

#### Definition statement

*This place covers:*

Rollers or wheeled devices interposed between the load and the ground

Illustrative example of subject matter classified in this group:

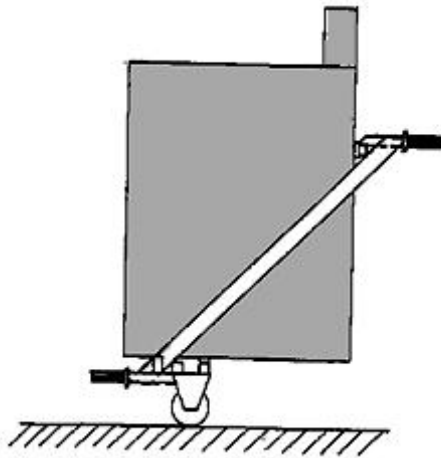

**References**

**Informative references**

Attention is drawn to the following places, which may be of interest for search:

Castors, wheels	<a href="#">B60B 33/00</a>
Handcarts	<a href="#">B62B 5/02</a>

**B65G 7/06**

using fluid at high pressure supplied from an independent source to provide a cushion between load and ground {(conveying articles over a flat surface by jets located in the surface [B65G 51/00](#))}

**Definition statement**

*This place covers:*

Illustrative example of subject matter classified in this group:

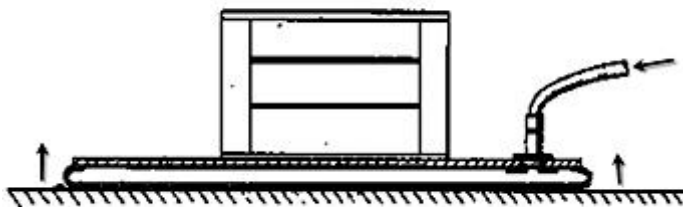

**References**

**Informative references**

Attention is drawn to the following places, which may be of interest for search:

Vehicles travelling on air cushions	<a href="#">B60V 3/025</a>
Air bearings	<a href="#">F16C 32/06</a>

## B65G 7/08

### for tilting the loads

#### Definition statement

*This place covers:*

Device interposed between the load and the ground for tilting the load. The article is usually stationary and is engagable by the device, gripping is not excluded but is not pick and place. What is important is that the device comes under the article.

Illustrative example of subject matter classified in this group:

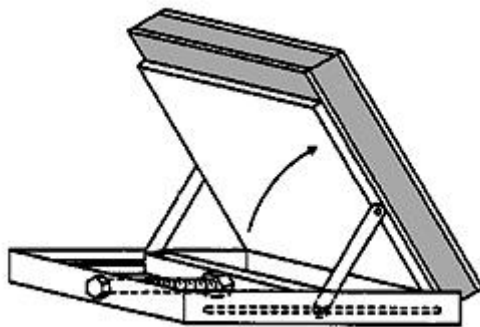

#### References

##### *Informative references*

*Attention is drawn to the following places, which may be of interest for search:*

Tilting and emptying containers)	<a href="#">B65G 65/23</a>
Tiltable platforms	<a href="#">B66F 7/22</a>

## B65G 7/10

### for rolling cylindrical loads

#### Definition statement

*This place covers:*

Device used for rolling the cylindrical load which is stationary. These devices can push, pull, enter in a hole in the load to engage it, lift it and use its inertia, etc.

Illustrative example of subject matter classified in this group:

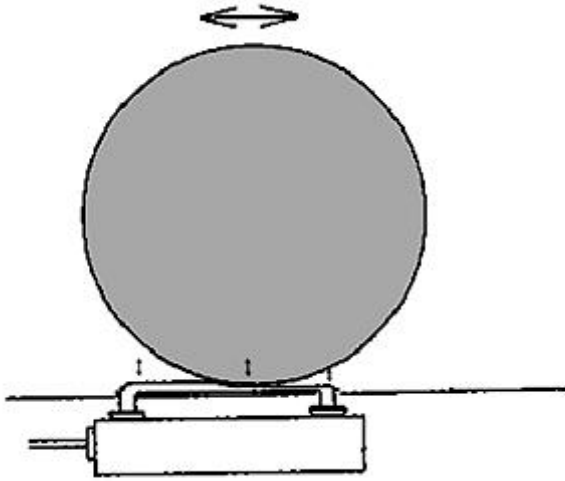

## References

### *Informative references*

*Attention is drawn to the following places, which may be of interest for search:*

Shifting railway cars	<a href="#">B61J 3/10</a> , <a href="#">B61J 3/12</a>
-----------------------	-------------------------------------------------------

## **B65G 7/12**

**Load carriers, e.g. hooks, slings, harness, gloves, modified for load carrying**

### **Definition statement**

*This place covers:*

Illustrative example of subject matter classified in this group:

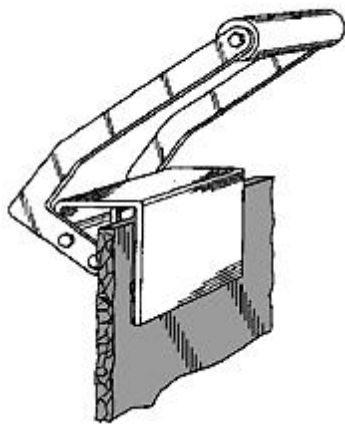

## References

### Informative references

Attention is drawn to the following places, which may be of interest for search:

Carrying means for fragile (glass) sheets	<a href="#">B65G 49/061</a>
Game (dead animals) carriers),	<a href="#">A01M 31/006</a>
Carrying straps, harnesses	<a href="#">A45F 3/14</a>
Holder or carriers for hand articles	<a href="#">A45F 5/00</a>
Stretcher for disabled persons	<a href="#">A61G 5/006</a>
Hand held gripping tools	<a href="#">B25B 9/00</a>
Handles, holders for small containers	<a href="#">B65D 25/28</a>
Hand-held carriers for reels	<a href="#">B65H 75/406</a>
Lifting devices for manhole covers),	<a href="#">B66F 19/005</a>
Handling tools for building elements	<a href="#">E04G 21/16</a>
Bricks holders	<a href="#">E04G 21/1808</a>

## B65G 9/00

**Apparatus for assisting manual handling having suspended load-carriers movable by hand or gravity**

### Definition statement

*This place covers:*

Illustrative example of subject matter classified in this group:

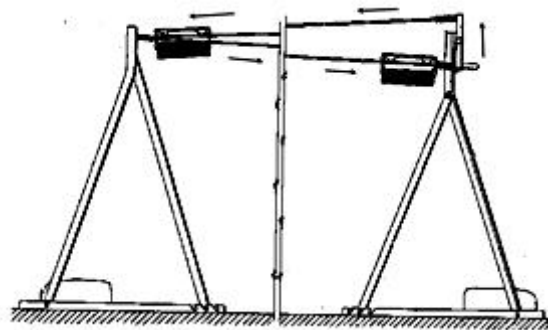
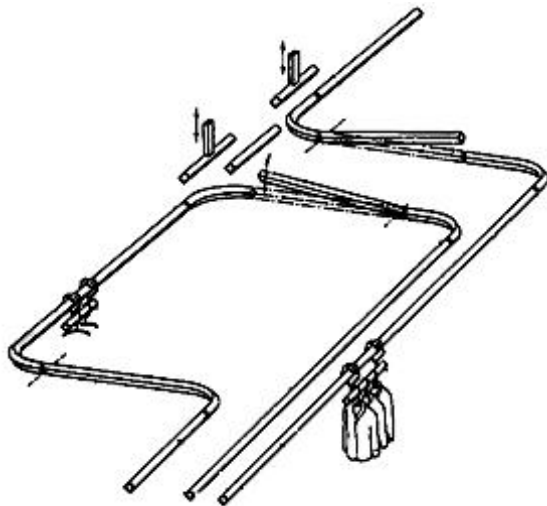

## References

### Informative references

Attention is drawn to the following places, which may be of interest for search:

Manually-operated endless-rope or chain conveyors	<a href="#">B65G 17/00</a>
Handling clothing hangers	<a href="#">A47G 25/1442</a>

Railway Systems	<a href="#">B61B</a>
Monorail railway systems	<a href="#">B61B 13/04</a>
Supplying bobbins with overhead conveying systems	<a href="#">D01H 9/182</a>
Handling laundry	<a href="#">D06F 95/00</a>

## **B65G 9/002**

{Load-carriers, rollers therefor}

### **Definition statement**

*This place covers:*

Illustrative example of subject matter classified in this group:

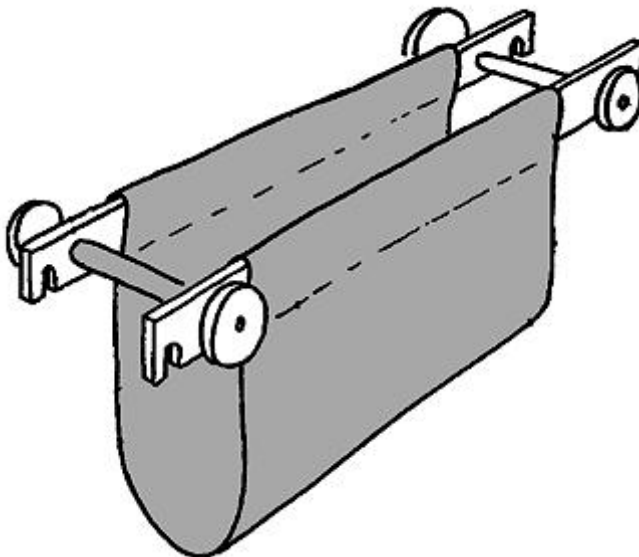

### **References**

#### **Informative references**

*Attention is drawn to the following places, which may be of interest for search:*

Rollers	<a href="#">B65G 39/00</a>
Suspended vehicles, trolleys	<a href="#">B61B 10/022</a>
Guiding rollers	<a href="#">F16C 13/006</a>

## B65G 9/004

{Loading or unloading arrangements}

### Definition statement

*This place covers:*

Illustrative example of subject matter classified in this group:

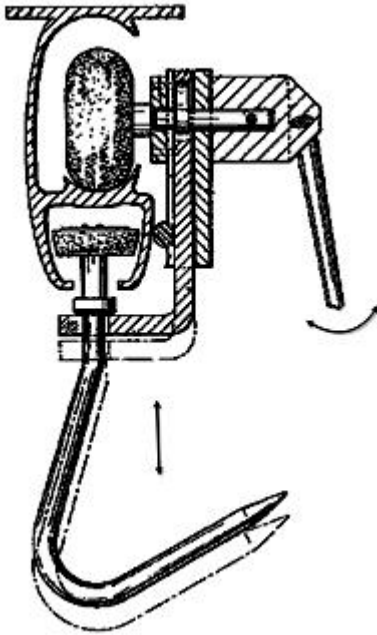

## B65G 9/006

{Arresting, braking or escapement means}

### Definition statement

*This place covers:*

Arresting means for loading/unloading purposes



Illustrative example of subject matter classified in this group:

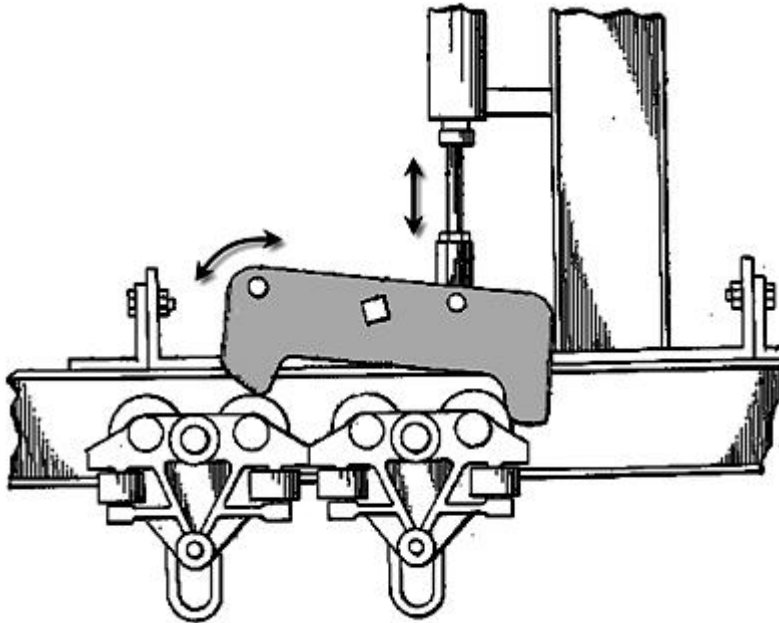

## **B65G 9/008**

{Rails or switches}

### **Definition statement**

*This place covers:*

Illustrative example of subject matter classified in this group:

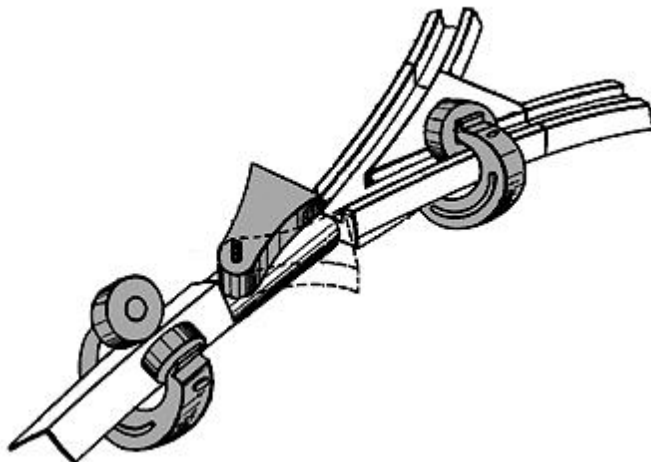

### **References**

#### **Informative references**

Attention is drawn to the following places, which may be of interest for search:

Rails	<a href="#">E01B 5/00</a>
Switches	<a href="#">E01B 7/00</a>

**B65G 11/00****Chutes (used as storage devices [B65G 1/02](#))****Definition statement**

*This place covers:*

Illustrative example of subject matter classified in this group:

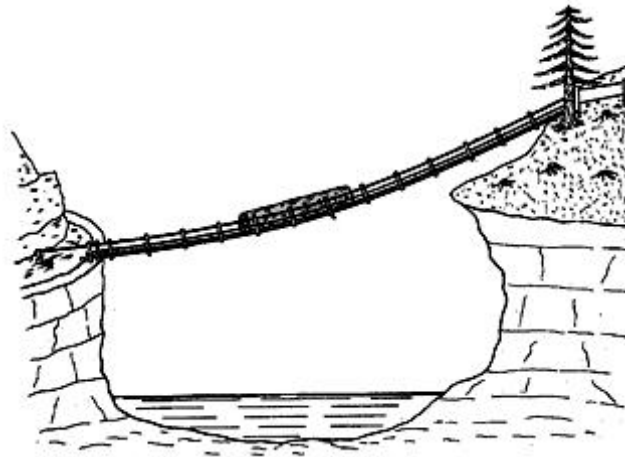
**References****Limiting references**

*This place does not cover:*

Used as storage devices	<a href="#">B65G 1/02</a>
-------------------------	---------------------------

**Application-oriented references**

*Examples of places where the subject matter of this place is covered when specially adapted, used for a particular purpose, or incorporated in a larger system:*

Feeding or discharging conveyors by devices incorporated in, or operatively associated with, conveyors	<a href="#">B65G 47/00</a>
Transferring bulk to several conveyors	<a href="#">B65G 47/72</a>
For sports, games, or amusements	<a href="#">A63G 21/00</a>
For refuse disposal in buildings	<a href="#">E04F 17/12</a>

**Informative references**

*Attention is drawn to the following places, which may be of interest for search:*

Chutes comprising a driven conveyor	<a href="#">B65G 37/00</a>
Slides for plane evacuation	<a href="#">A62B 1/20</a>
Discharging chutes for cement	<a href="#">B28C 5/4248</a>
Hoppers, i.e. containers having funnel-shaped discharge sections	<a href="#">B65D 88/26</a>
Switches	<a href="#">E01B 7/00</a>

**B65G 11/02**  
**of straight form**

**Definition statement**

*This place covers:*

Illustrative example of subject matter classified in this group:

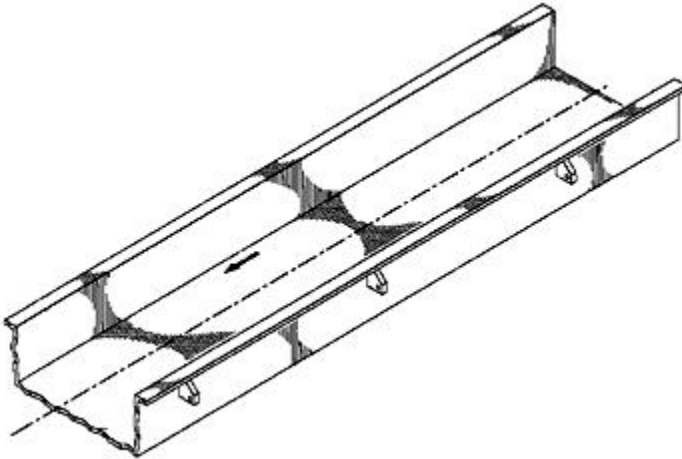

**B65G 11/023**  
**{for articles}**

**Definition statement**

*This place covers:*

Illustrative example of subject matter classified in this group:

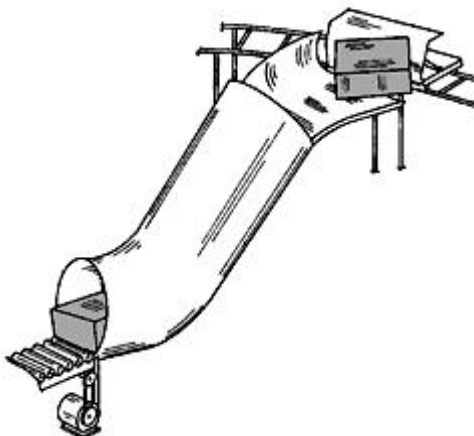

## B65G 11/026

{for bulk}

### Definition statement

*This place covers:*

Illustrative example of subject matter classified in this group:

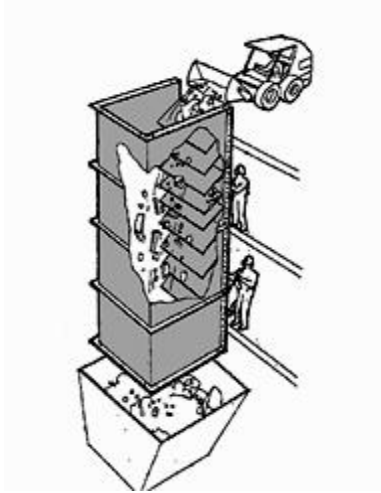

## **B65G 11/04**

**for mail in buildings**

### **Definition statement**

*This place covers:*

Illustrative example of subject matter classified in this group:

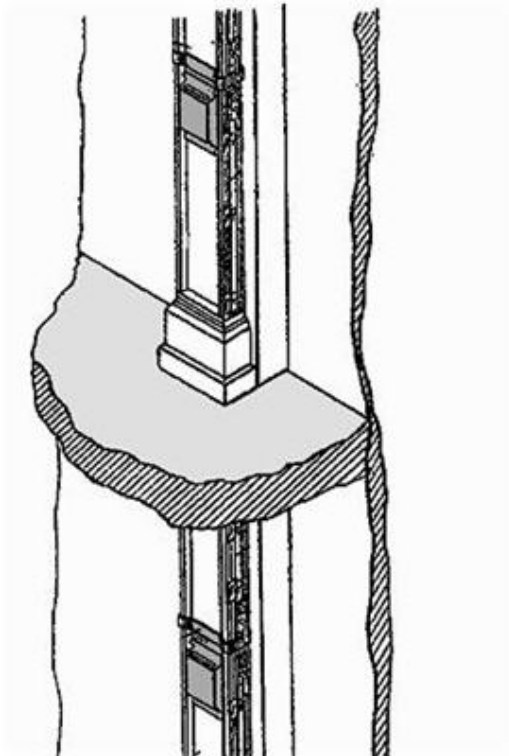

## **B65G 11/06**

### **of helical or spiral form**

#### **Definition statement**

*This place covers:*

Illustrative example of subject matter classified in this group:

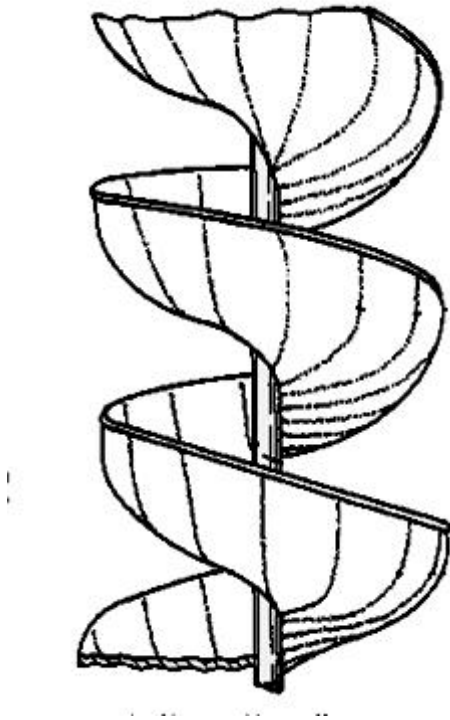

#### **References**

##### **Limiting references**

*This place does not cover:*

For discontinuous spiral chutes	<a href="#">B65G 11/083</a>
---------------------------------	-----------------------------

## B65G 11/063

{for articles}

### Definition statement

*This place covers:*

Illustrative example of subject matter classified in this group:

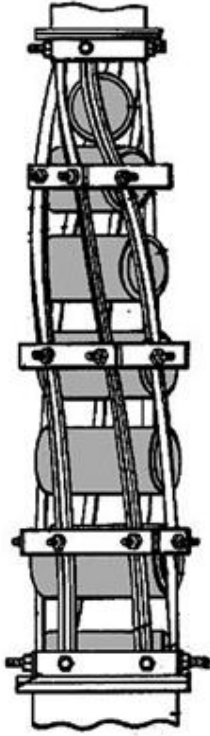

## **B65G 11/066**

**{for bulk}**

### **Definition statement**

*This place covers:*

Illustrative example of subject matter classified in this group:

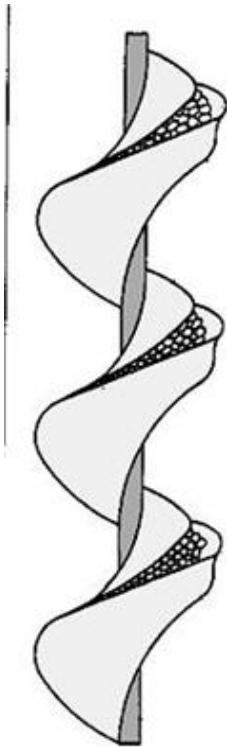

## **B65G 11/081**

**{for articles ([B65G 11/085](#) takes precedence)}**

### **Definition statement**

*This place covers:*

Discrete articles have usually different inherent features than those for bulk (powdery, ore, etc) material



Illustrative example of subject matter classified in this group:

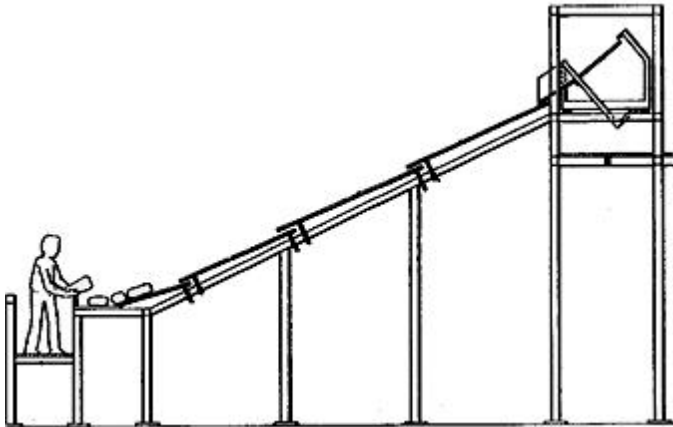

**References**

**Limiting references**

*This place does not cover:*

With zig-zag formations	<a href="#">B65G 11/085</a>
-------------------------	-----------------------------

**B65G 11/083**

{for bulk ([B65G 11/085](#) takes precedence)}

**Definition statement**

*This place covers:*

Illustrative example of subject matter classified in this group:

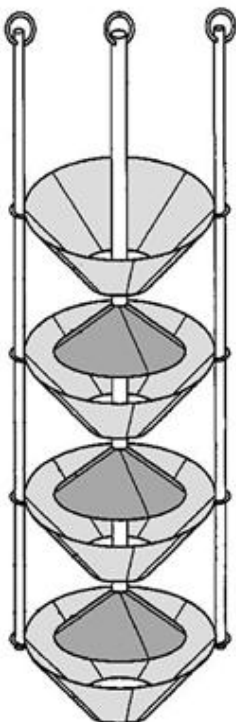

## References

### Limiting references

*This place does not cover:*

With zig-zag formations	<a href="#">B65G 11/085</a>
-------------------------	-----------------------------

### Informative references

*Attention is drawn to the following places, which may be of interest for search:*

For bulk	<a href="#">B65G 11/146</a>
----------	-----------------------------

## B65G 11/086

{for articles}

### Definition statement

*This place covers:*

Chutes conveying discrete articles have usually different inherent features than those for bulk (powdery, ore, etc) material.

Illustrative example of subject matter classified in this group:

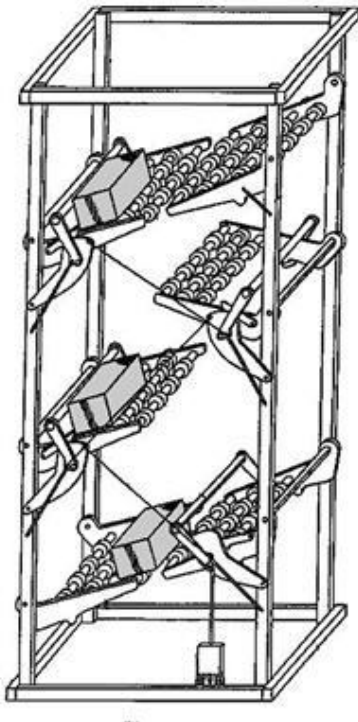

## **B65G 11/088**

**{for bulk}**

### **Definition statement**

*This place covers:*

Chutes conveying bulk (powdery, ore, etc) material have usually different inherent features than those for discrete articles like packages.

Illustrative example of subject matter classified in this group:

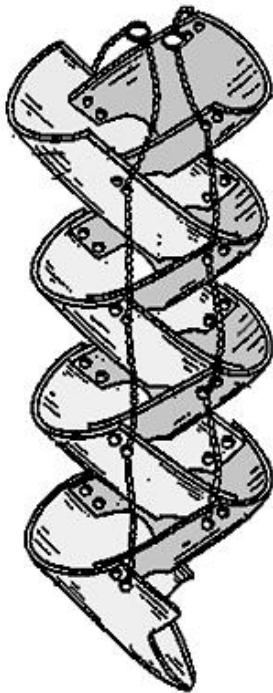

## **B65G 11/103**

**{for articles}**

### **Definition statement**

*This place covers:*

Chutes conveying discrete articles have usually different inherent features than those for bulk (powdery, ore, etc) material.

Illustrative example of subject matter classified in this group:

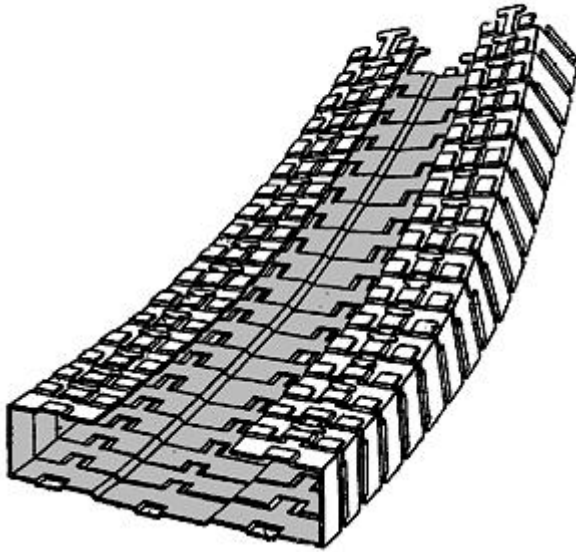

## **B65G 11/106**

{for bulk}

### **Definition statement**

*This place covers:*

Chutes conveying bulk (powdery, ore, etc) material have usually different inherent features than those for discrete articles like packages.

Illustrative example of subject matter classified in this group:

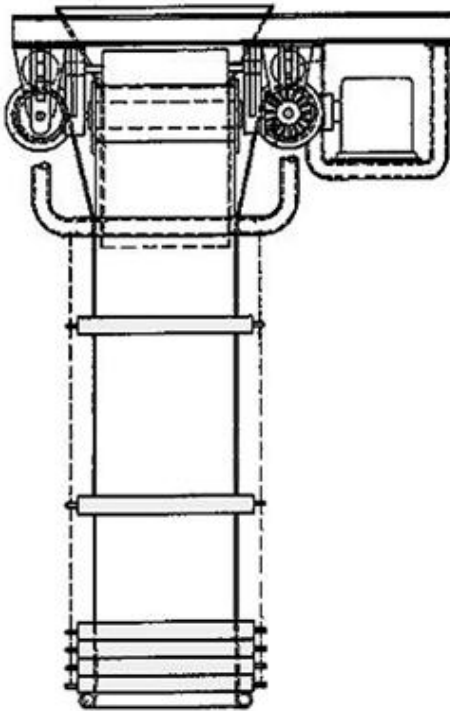

**B65G 11/123**

{for articles}

**Definition statement**

*This place covers:*

Illustrative example of subject matter classified in this group:

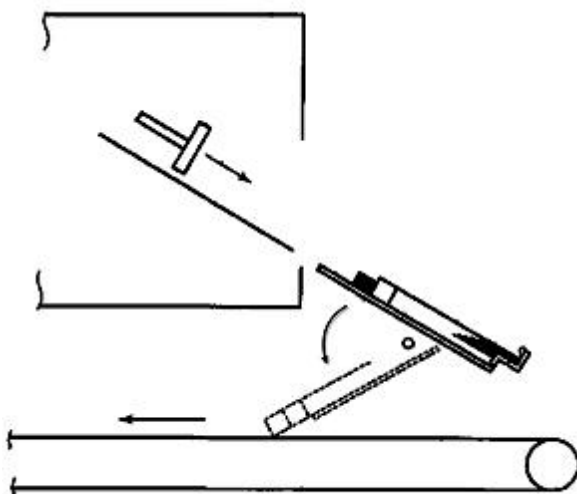

## B65G 11/126

{for bulk}

### Definition statement

*This place covers:*

Illustrative example of subject matter classified in this group:

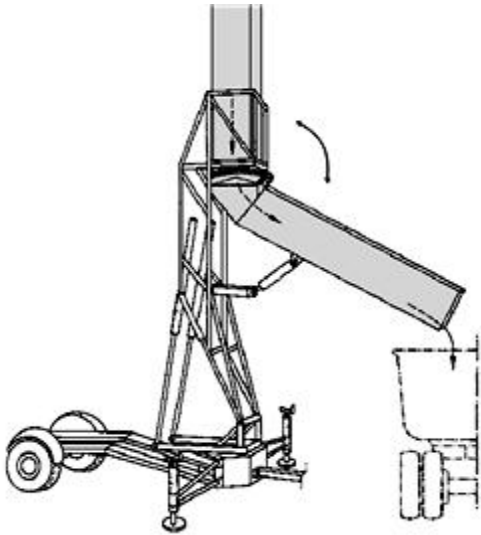

### References

#### Limiting references

*This place does not cover:*

With discontinuous guiding surfaces	<a href="#">B65G 11/083</a>
-------------------------------------	-----------------------------

## B65G 11/143

{for articles}

### Definition statement

*This place covers:*

Illustrative example of subject matter classified in this group:

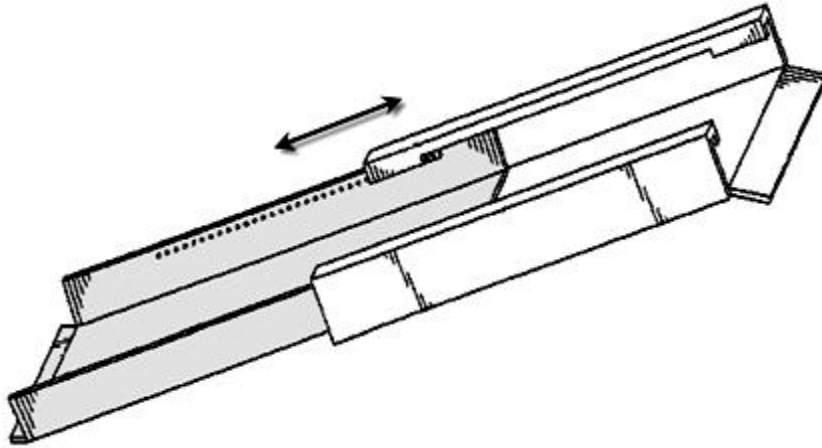

## B65G 11/146

{for bulk}

### Definition statement

*This place covers:*

Illustrative example of subject matter classified in this group:

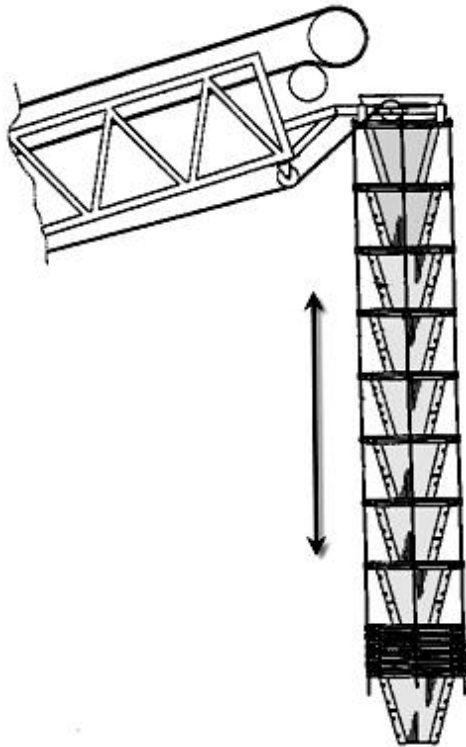

### References

#### *Informative references*

*Attention is drawn to the following places, which may be of interest for search:*

Not adjustable	<a href="#">B65G 11/083</a>
----------------	-----------------------------



## B65G 11/16

### Interior surfaces; Linings

#### Definition statement

*This place covers:*

Illustrative example of subject matter classified in this group:

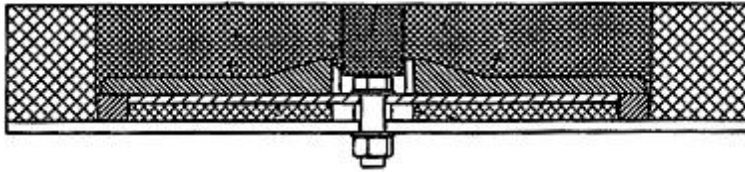

## B65G 11/163

{for articles}

#### Definition statement

*This place covers:*

Illustrative example of subject matter classified in this group:

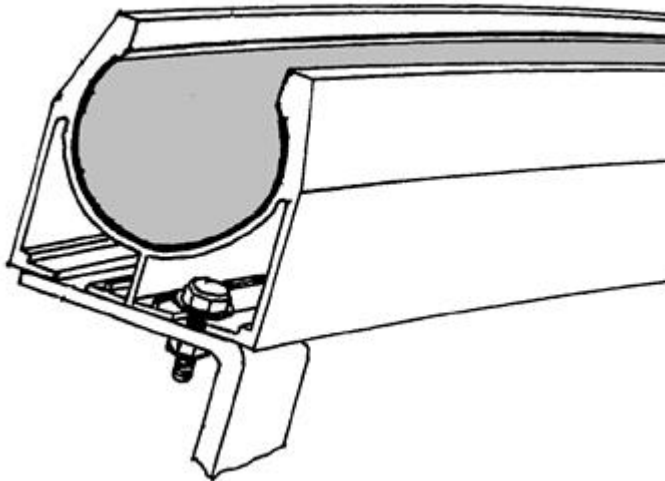

## B65G 11/166

{for bulk}

### Definition statement

*This place covers:*

Illustrative example of subject matter classified in this group:

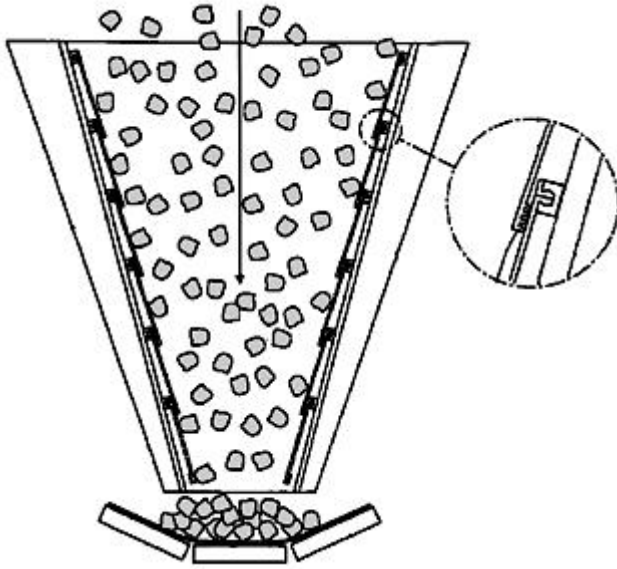

## B65G 11/183

{for articles}

### Definition statement

*This place covers:*

Illustrative example of subject matter classified in this group:

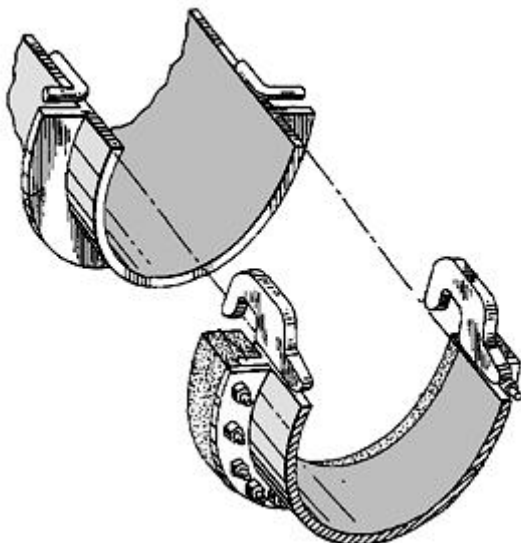

## B65G 11/186

{for bulk}

### Definition statement

*This place covers:*

Illustrative example of subject matter classified in this group:

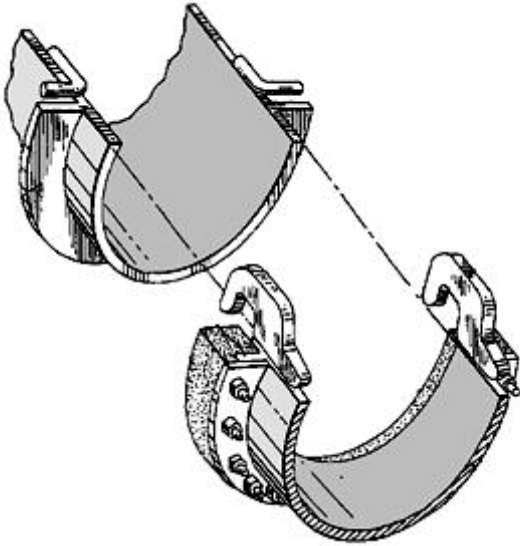

**B65G 11/203****{for articles}****Definition statement***This place covers:*

Illustrative example of subject matter classified in this group:

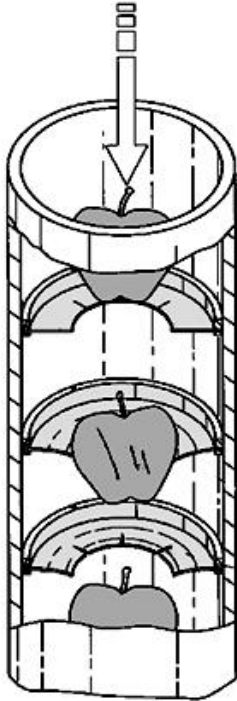
**References*****Limiting references****This place does not cover:*

Pivotable switches	<a href="#">B65G 47/71</a>
--------------------	----------------------------

***Informative references****Attention is drawn to the following places, which may be of interest for search:*

Preventing damage to the goods or materials	<a href="#">B65G 69/16</a>
---------------------------------------------	----------------------------

## B65G 11/206

{for bulk}

### Definition statement

*This place covers:*

Illustrative example of subject matter classified in this group:

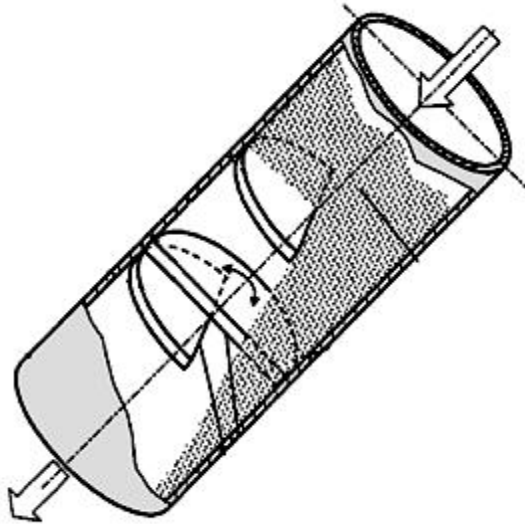

### References

#### Limiting references

*This place does not cover:*

Pivotable switches	<a href="#">B65G 47/72</a>
--------------------	----------------------------

## B65G 13/00

Roller-ways (storage devices comprising roller-ways [B65G 1/02](#); endless-chain conveyors comprising load-supporting rollers [B65G 17/00](#); rollers or arrangements thereof [B65G 39/00](#))

### Definition statement

*This place covers:*

Illustrative example of subject matter classified in this group:

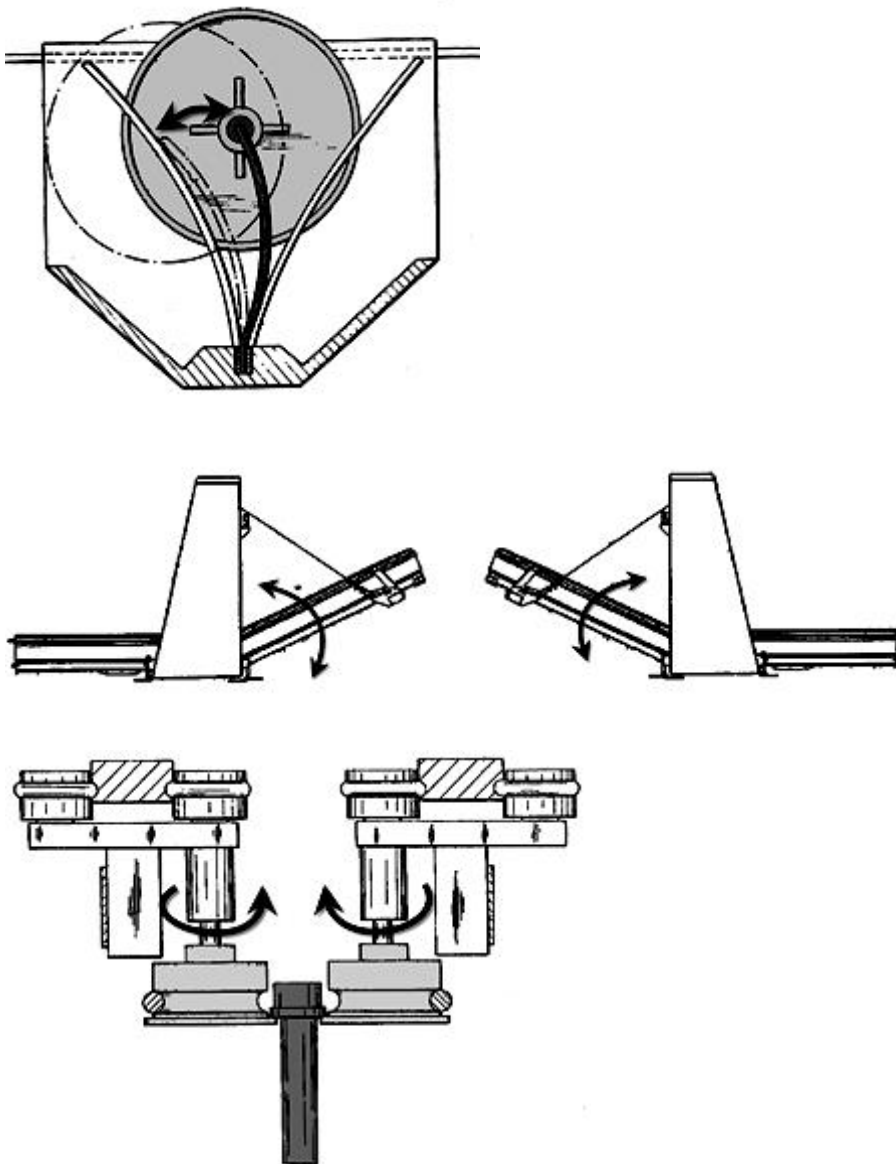

### References

#### Limiting references

*This place does not cover:*

Storage devices comprising roller-ways	<a href="#">B65G 1/02</a>
Endless-chain conveyors comprising load-supporting rollers	<a href="#">B65G 17/00</a>

Rollers or arrangements thereof	<a href="#">B65G 39/00</a>
---------------------------------	----------------------------

**Application-oriented references**

*Examples of places where the subject matter of this place is covered when specially adapted, used for a particular purpose, or incorporated in a larger system:*

In metal-rolling equipment	<a href="#">B21B 39/00</a> , <a href="#">B21B 41/00</a>
----------------------------	---------------------------------------------------------

**Informative references**

*Attention is drawn to the following places, which may be of interest for search:*

Pivoting part(s) to permit passage of people	<a href="#">B65G 21/00</a>
Articles conveyed in the gap between two horizontal and parallel rollers	<a href="#">B65G 35/00</a>
Feeding timber with pressure rollers	<a href="#">B27B 25/02</a>
Castors	<a href="#">B60B 33/00</a>
Rollers in vehicles	<a href="#">B60P 1/52</a>
Transporting glass sheets with rollers	<a href="#">C03B 35/16</a>
Rollers in general	<a href="#">F16C 13/00</a>
Roller conveyors for ovens	<a href="#">F27B 9/2407</a>

**B65G 13/02**

**having driven rollers**

**Definition statement**

*This place covers:*

Illustrative example of subject matter classified in this group:

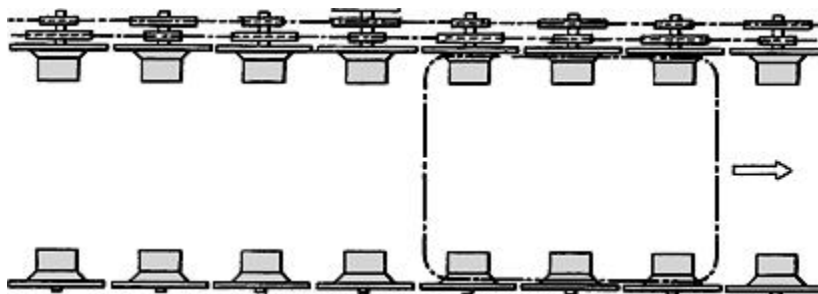

**References**

**Limiting references**

*This place does not cover:*

Roller-ways having all rollers driven	<a href="#">B65G 13/04</a>
---------------------------------------	----------------------------

**Informative references**

*Attention is drawn to the following places, which may be of interest for search:*

Driven drums	<a href="#">B65G 23/04</a>
--------------	----------------------------

## B65G 13/04

all rollers driven

### Definition statement

*This place covers:*

Illustrative example of subject matter classified in this group:

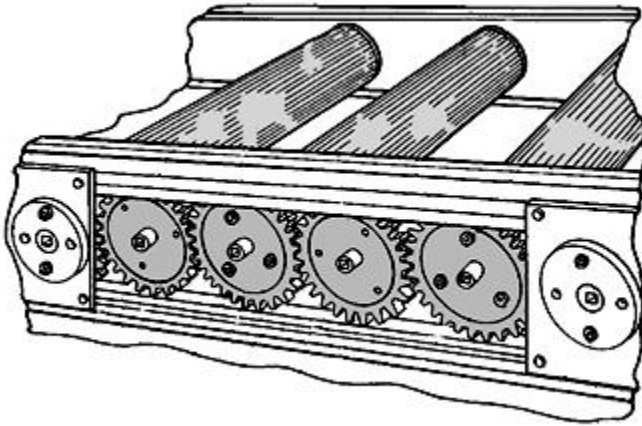

## B65G 13/06

Roller driving means

### Definition statement

*This place covers:*

Control of the drive

Illustrative example of subject matter classified in this group:

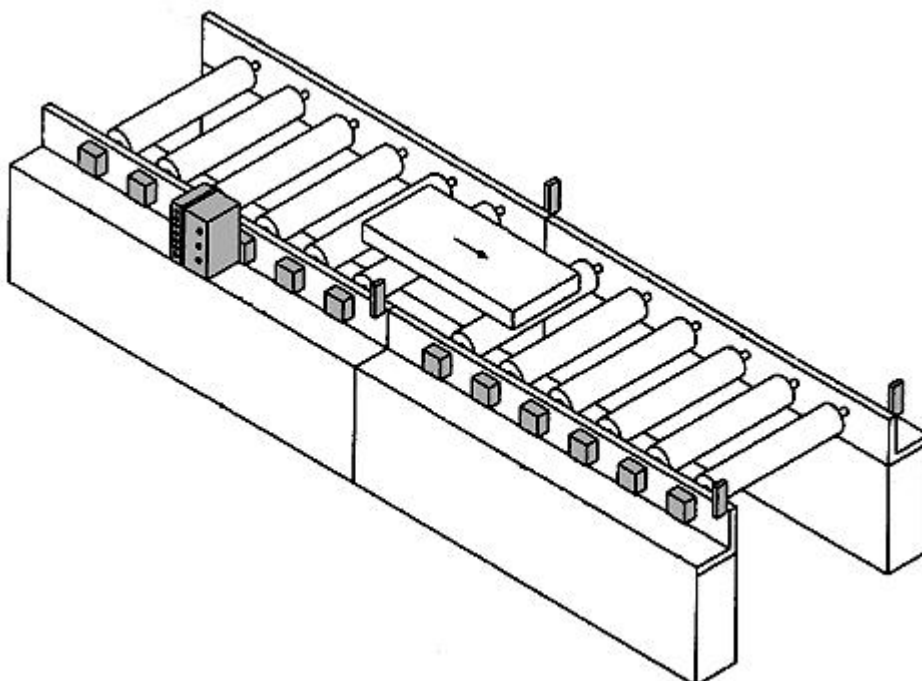



## B65G 13/065

{with displacement of the roller}

### Definition statement

*This place covers:*

Illustrative example of subject matter classified in this group:

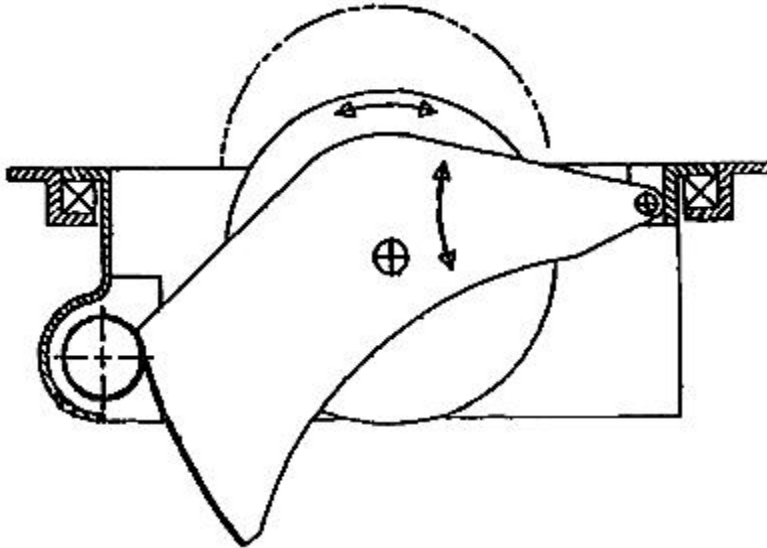

### References

#### *Informative references*

*Attention is drawn to the following places, which may be of interest for search:*

Roller-ways for handling freight for aircrafts	<a href="#">B64D 9/00</a>
------------------------------------------------	---------------------------

**B65G 13/07****having endless driving elements****Definition statement***This place covers:*

Illustrative example of subject matter classified in this group:

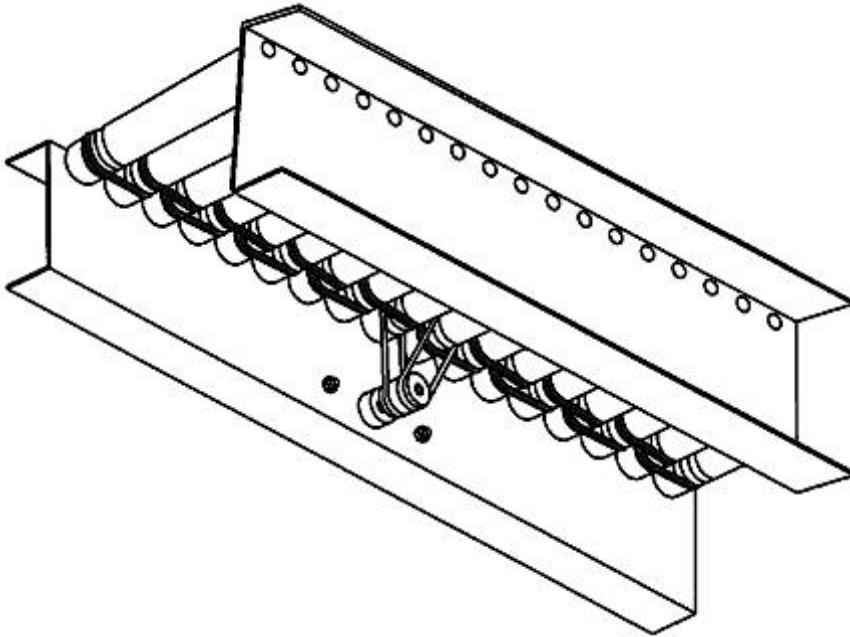
**B65G 13/071****with frictional engagement****Definition statement***This place covers:*

Illustrative example of subject matter classified in this group:

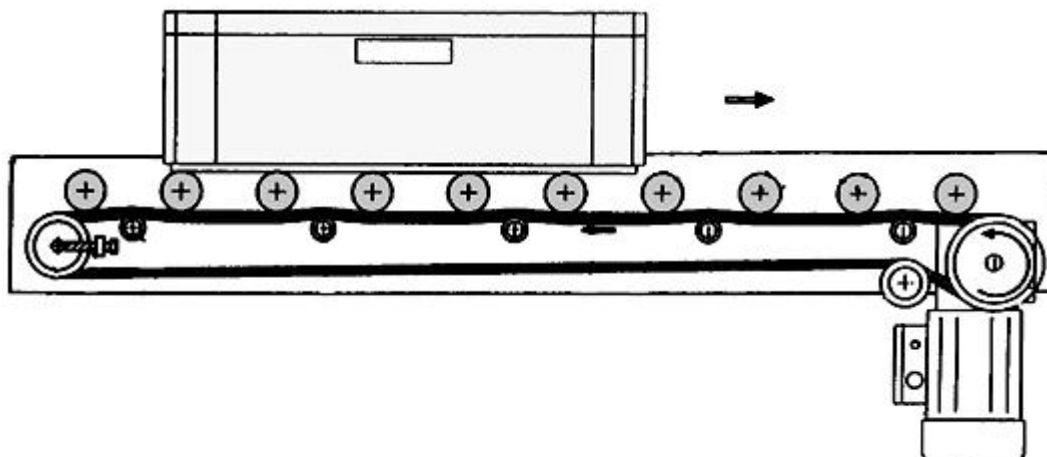

**B65G 13/073****comprising free-wheel gearing****Definition statement***This place covers:*

Illustrative example of subject matter classified in this group:

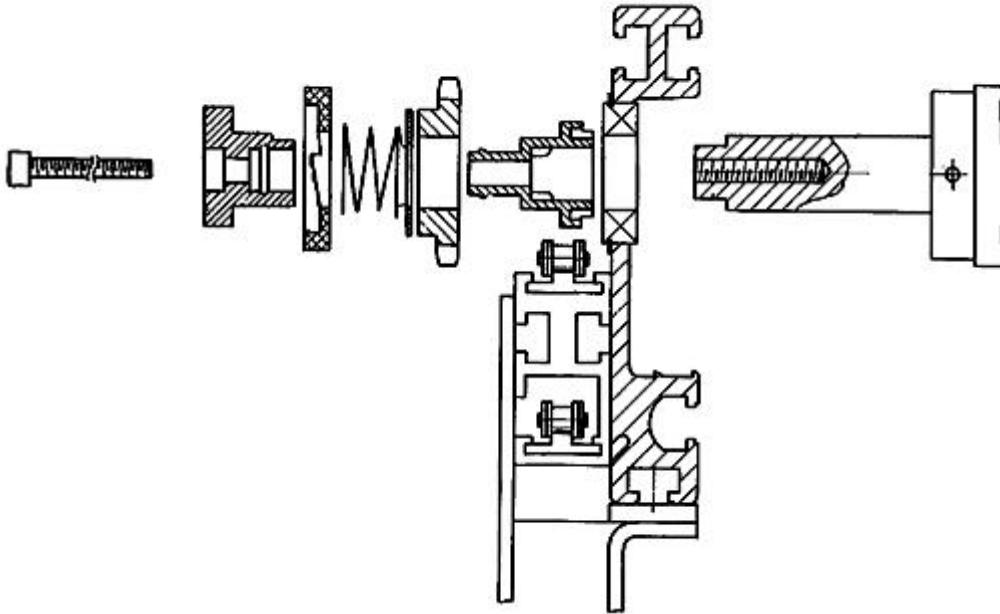
**References****Informative references***Attention is drawn to the following places, which may be of interest for search:*

Accumulating conveyor	<a href="#">B65G 47/263</a>
Slip couplings	<a href="#">F16D 7/00</a>
Freewheels	<a href="#">F16D 41/00</a>

**B65G 13/075****Braking means****Definition statement**

*This place covers:*

Illustrative example of subject matter classified in this group:

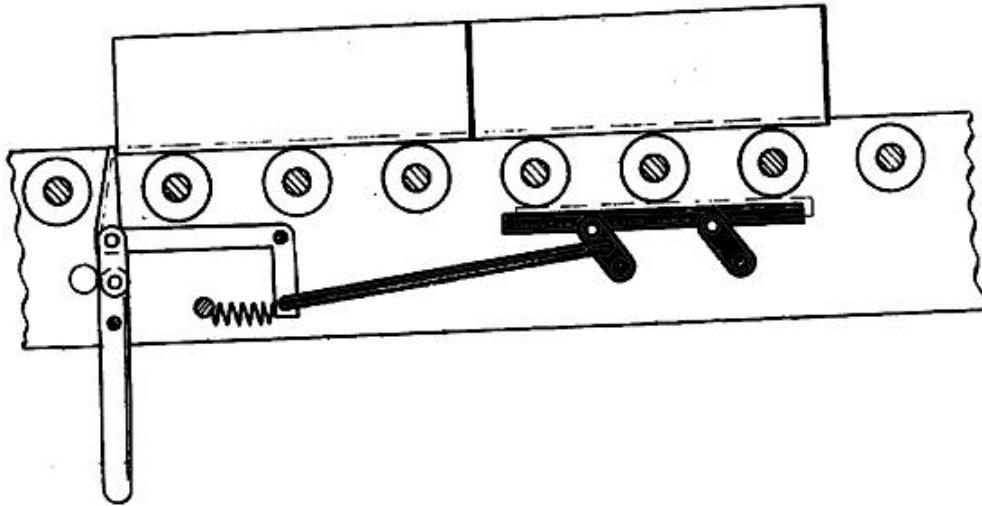
**References****Informative references**

*Attention is drawn to the following places, which may be of interest for search:*

Stopping articles	<a href="#">B65G 47/88</a>
Braking devices for metal-rolling mills	<a href="#">B21B 39/12</a>
Braking devices in cooling bed conveyors	<a href="#">B21B 43/00</a>
Brakes for sheet material conveyors	<a href="#">B65H 29/68</a>
Brakes	<a href="#">F16D</a>

## B65G 13/08

of curved form; with branch-offs

### Definition statement

*This place covers:*

Illustrative example of subject matter classified in this group:

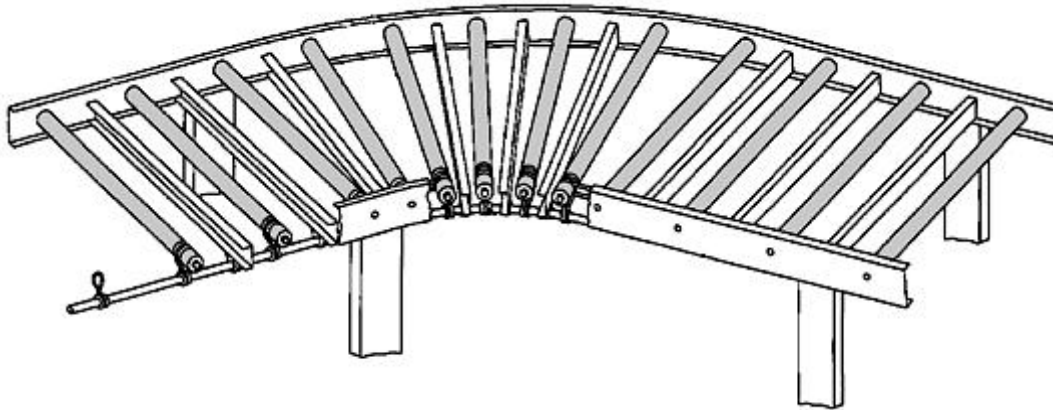

### References

#### *Informative references*

*Attention is drawn to the following places, which may be of interest for search:*

Curved path conveyors	<a href="#">B65G 21/18</a> , <a href="#">B65G 21/16</a>
-----------------------	---------------------------------------------------------

## B65G 13/10

### Switching arrangements

#### Definition statement

*This place covers:*

Illustrative example of subject matter classified in this group:

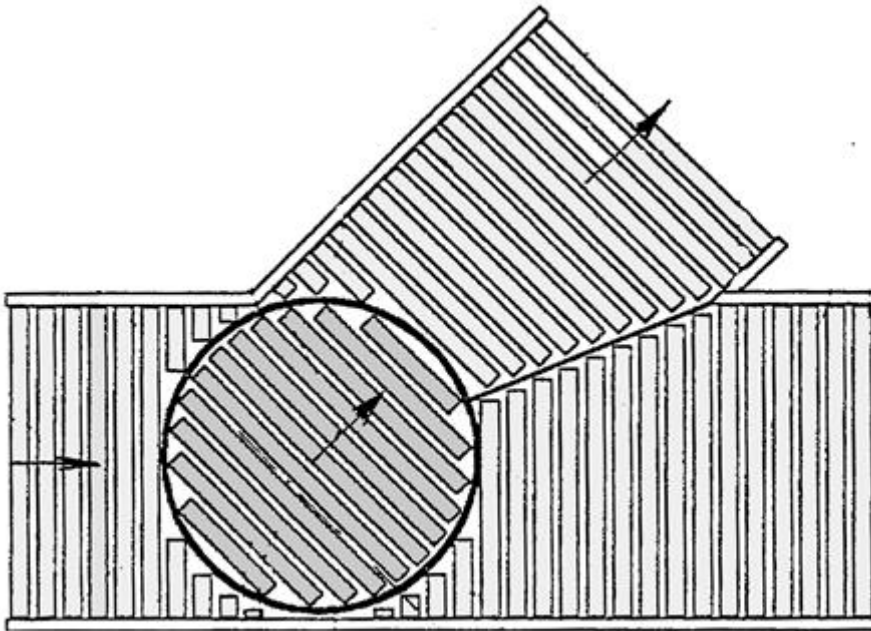

#### References

##### *Informative references*

*Attention is drawn to the following places, which may be of interest for search:*

Transferring articles	<a href="#">B65G 47/54</a> , <a href="#">B65G 47/64</a> , <a href="#">B65G 47/71</a>
Ball-rollers (for ball-rollers combine with omniroll)	<a href="#">B65G 2207/34</a>

## B65G 13/11

### Roller frames

#### Definition statement

*This place covers:*

How the frame is constructed in a roller way in general

Illustrative example of subject matter classified in this group:

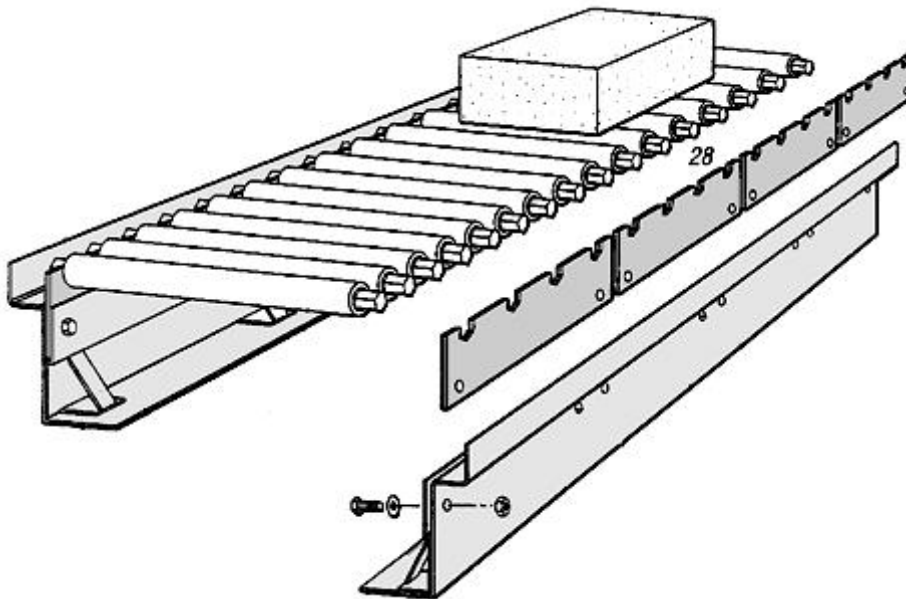

## References

### Informative references

Attention is drawn to the following places, which may be of interest for search:

Racks equipped with rollers	<a href="#">B65G 1/023</a>
Frames for endless conveyors	<a href="#">B65G 21/00</a>
Lateral guidance means	<a href="#">B65G 21/2072</a>
Mounting rollers on frames	<a href="#">B65G 39/12</a>
Roller mounted on framework	<a href="#">B65G 39/12</a>
Roll-stand for metal rolling mills	<a href="#">B21B 39/12</a>
Undercarriages for supports with telescoping pillar	<a href="#">F16M 11/28</a>

## B65G 13/12

### adjustable

### Definition statement

*This place covers:*

Roller frames which can be telescopic, extending, flexible, submerging and rising, etc.

Illustrative example of subject matter classified in this group:

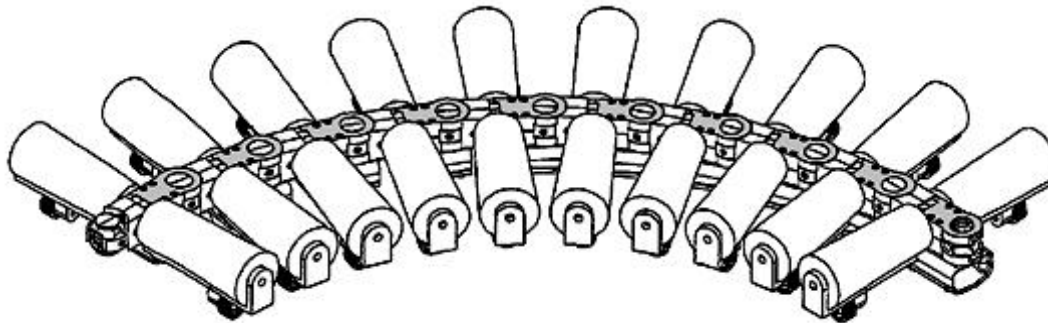

## References

### Informative references

Attention is drawn to the following places, which may be of interest for search:

Frames with movable parts	<a href="#">B65G 21/10</a>
Work or tool supports	<a href="#">B23Q 1/40</a>
Loading station for presses	<a href="#">B30B 15/028</a>

## B65G 15/00

**Conveyors having endless load-conveying surfaces, i.e. belts and like continuous members, to which tractive effort is transmitted by means other than endless driving elements of similar configuration (having load-conveying surfaces formed by interconnected longitudinal links [B65G 17/06](#))**

## References

### Limiting references

This place does not cover:

Having load-conveying surfaces formed by interconnected longitudinal links	<a href="#">B65G 17/06</a>
----------------------------------------------------------------------------	----------------------------

### Informative references

Attention is drawn to the following places, which may be of interest for search:

Feeding or discharging conveyors by devices incorporated in, or operatively associated with conveyors	<a href="#">B65G 47/00</a>
Loading or unloading	<a href="#">B65G 65/00</a>
Advertising elements	<a href="#">B65G 2207/04</a>
Weighing belt conveyors	<a href="#">G01G 11/00</a>
Advertisement on belts	<a href="#">G09F 19/22</a> , <a href="#">G09F 11/12</a>



## **B65G 15/005**

{the surface being formed by one rope}

### **Definition statement**

*This place covers:*

Illustrative example of subject matter classified in this group:

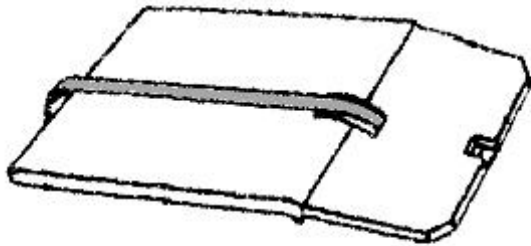

## **B65G 15/02**

for conveying in a circular arc

### **Definition statement**

*This place covers:*

Illustrative example of subject matter classified in this group:

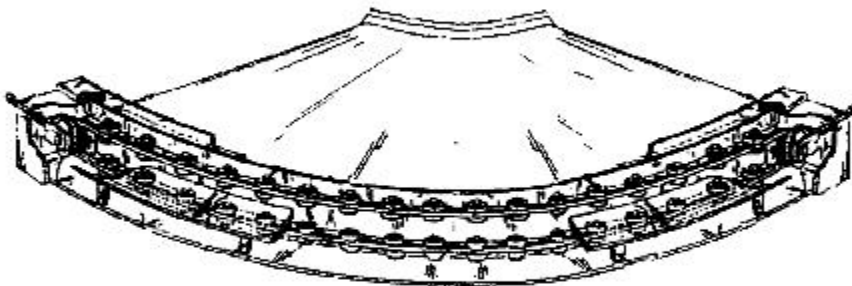

## B65G 15/04

the load being carried on the lower run of the endless surface

### Definition statement

*This place covers:*

Illustrative example of subject matter classified in this group:

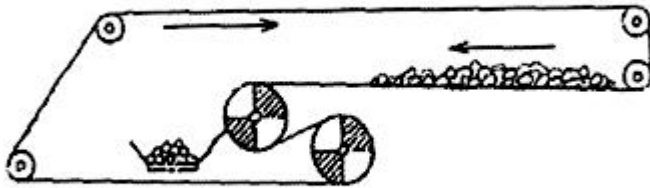

## B65G 15/06

with oppositely-moving parts of the endless surface located in the same plane and parallel to one another

### Definition statement

*This place covers:*

Illustrative example of subject matter classified in this group:

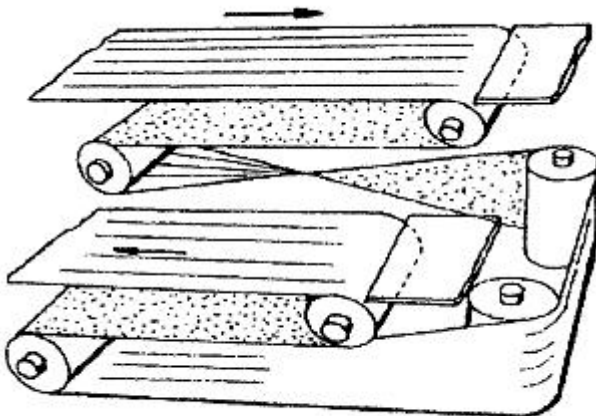

**B65G 15/08**

the load-carrying surface being formed by a concave or tubular belt, e.g. a belt forming a trough

**Definition statement**

*This place covers:*

Illustrative example of subject matter classified in this group:

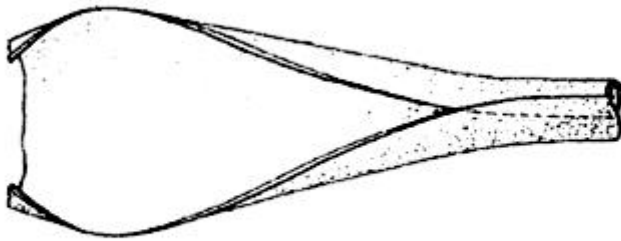
**References****Limiting references**

*This place does not cover:*

For the structure of the belt	<a href="#">B65G 15/40</a>
-------------------------------	----------------------------

**B65G 15/10**

comprising two or more co-operating endless surfaces with parallel longitudinal axes, or a multiplicity of parallel elements, e.g. ropes defining an endless surface

**Definition statement**

*This place covers:*

Illustrative example of subject matter classified in this group:

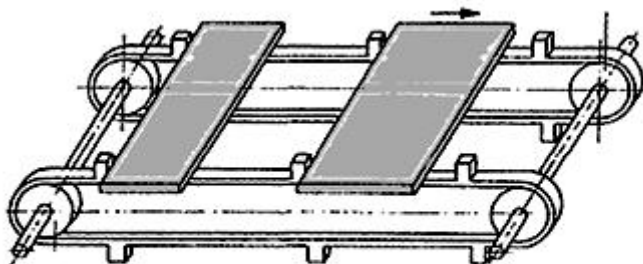

**B65G 15/105**

{the surface being formed by two or more ropes}

**Definition statement**

*This place covers:*

Illustrative example of subject matter classified in this group:

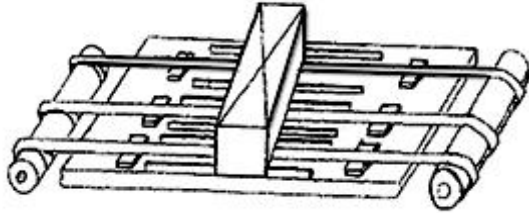
**References****Limiting references**

*This place does not cover:*

With two or more belts	<a href="#">B65G 15/50</a>
------------------------	----------------------------

**B65G 15/12**

with two or more endless belts

**Definition statement**

*This place covers:*

Illustrative example of subject matter classified in this group:

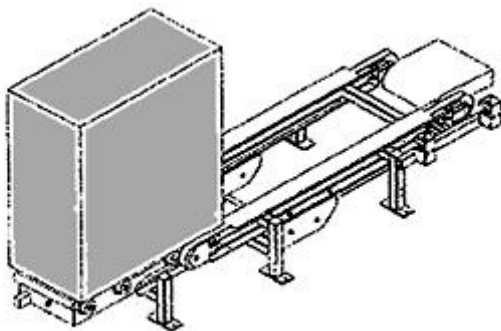

**B65G 15/14**

the load being conveyed between the belts {([B65G 15/18](#), [B65G 15/20](#) take precedence)}

**Definition statement**

*This place covers:*

If one belt is removed the system does not function, i.e. object can not be conveyed anymore.

Illustrative example of subject matter classified in this group:

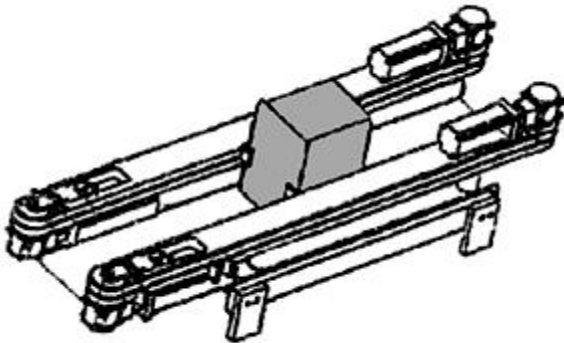
**References****Limiting references**

*This place does not cover:*

Conveyors having endless load-conveying surfaces the belts being sealed at their edges	<a href="#">B65G 15/18</a>
Conveyors for flat articles having endless load-conveying surfaces arranged side-by-side	<a href="#">B65G 15/20</a>

**B65G 15/16**

between an auxiliary belt and a main belt

**Definition statement**

*This place covers:*

Illustrative example of subject matter classified in this group:

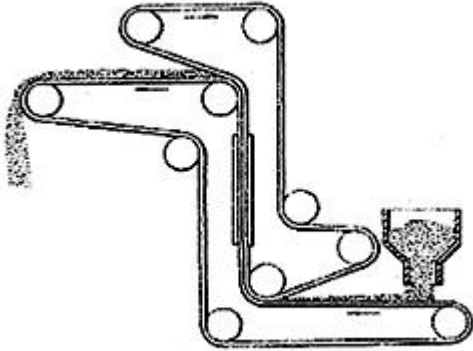
**B65G 15/18**

the belts being sealed at their edges

**Definition statement**

*This place covers:*

Illustrative example of subject matter classified in this group:

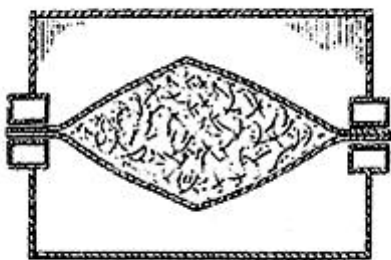
**References****Informative references**

*Attention is drawn to the following places, which may be of interest for search:*

Endless-surface conveyors having a single belt with sealed edges	<a href="#">B65G 15/08</a>
------------------------------------------------------------------	----------------------------

**B65G 15/20**

arranged side by side, e.g. for conveyance of flat articles in vertical position

**Definition statement**

*This place covers:*

Only for flat articles.

Illustrative example of subject matter classified in this group:

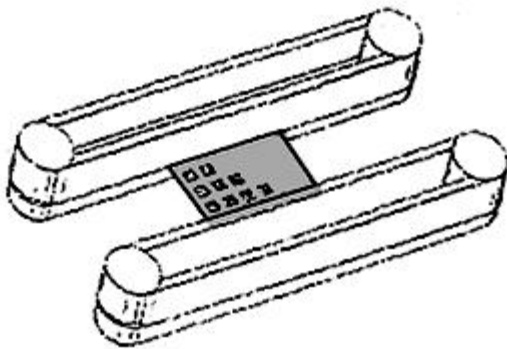
**References****Limiting references**

*This place does not cover:*

For other articles	<a href="#">B65G 15/14</a>
--------------------	----------------------------

**Application-oriented references**

*Examples of places where the subject matter of this place is covered when specially adapted, used for a particular purpose, or incorporated in a larger system:*

For conveying sheets or like thin flat articles	<a href="#">B65H</a>
-------------------------------------------------	----------------------

**Informative references**

*Attention is drawn to the following places, which may be of interest for search:*

For other articles	<a href="#">B65G 15/14</a>
Between chains	<a href="#">B65G 37/005</a>

**Special rules of classification**

For flat articles only, otherwise [B65G 15/14](#).

## **B65G 15/22**

**comprising a series of co-operating units**

### **Definition statement**

*This place covers:*

Illustrative example of subject matter classified in this group:

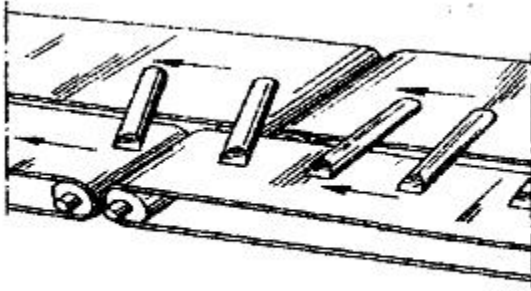

## **B65G 15/24**

**in tandem**

### **Definition statement**

*This place covers:*

Illustrative example of subject matter classified in this group:

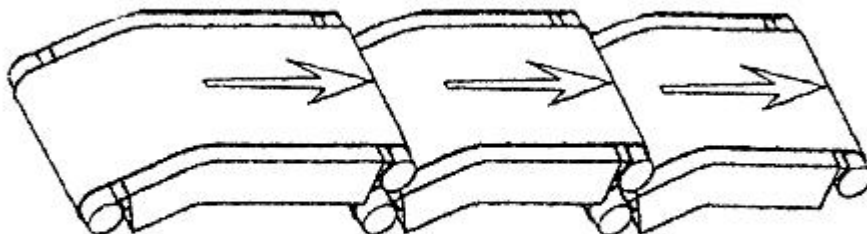



**B65G 15/26**

extensible, e.g. telescopic {(adjustment of length or configuration of load-carrier [B65G 21/14](#))}

**Definition statement**

*This place covers:*

Illustrative example of subject matter classified in this group:

**B65G 15/30**

Belts or like endless load-carriers (co-operating with rails or the like [B65G 21/22](#); {co-operating} with rollers [B65G 39/20](#))

**References****Limiting references**

*This place does not cover:*

Co-operating with rails or the like	<a href="#">B65G 21/22</a>
With rollers	<a href="#">B65G 39/20</a>

**Informative references**

*Attention is drawn to the following places, which may be of interest for search:*

Driving belts in general	<a href="#">F16G</a>
Belt fastenings (joining the two ends of a belt)	<a href="#">F16G 3/00</a>

**B65G 15/32****made of rubber or plastics****Definition statement***This place covers:*

Illustrative example of subject matter classified in this group:

**References****Informative references***Attention is drawn to the following places, which may be of interest for search:*

Manufacture of rubber/plastic belts	<a href="#">B29C 33/00</a> , <a href="#">B29D 29/00</a>
-------------------------------------	---------------------------------------------------------

**B65G 15/34****with reinforcing layers, e.g. of fabric****Definition statement***This place covers:*

Illustrative example of subject matter classified in this group:

**References****Informative references***Attention is drawn to the following places, which may be of interest for search:*

Woven fabrics	<a href="#">D03D</a>
---------------	----------------------

**B65G 15/36**

the layers incorporating ropes, chains, or rolled steel sections

**Definition statement**

*This place covers:*

Illustrative example of subject matter classified in this group:

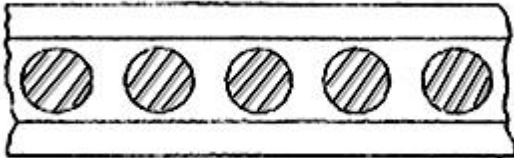
**B65G 15/38**

with flame-resistant layers, e.g. of asbestos, glass

**Definition statement**

*This place covers:*

Illustrative example of subject matter classified in this group:

**References****Informative references**

Attention is drawn to the following places, which may be of interest for search:

Belts for ovens, furnaces	<a href="#">F27B 9/243</a>
---------------------------	----------------------------

## B65G 15/40

troughed or tubular; formed with joints facilitating troughing

### Definition statement

*This place covers:*

Illustrative example of subject matter classified in this group:

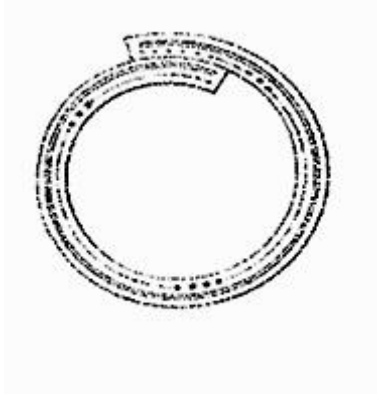

## B65G 15/42

having ribs, ridges, or other surface projections

### Definition statement

*This place covers:*

Illustrative example of subject matter classified in this group:

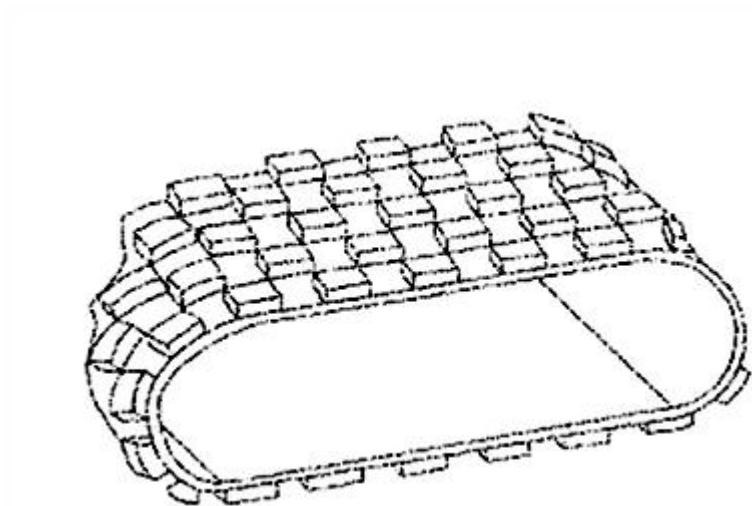

### References

#### Limiting references

*This place does not cover:*

Conveyors for impelling the loads	<a href="#">B65G 15/44</a>
-----------------------------------	----------------------------

**Informative references**

Attention is drawn to the following places, which may be of interest for search:

Toothed belt	<a href="#">B65G 15/64</a>
--------------	----------------------------

**B65G 15/44**

for impelling the loads

**Definition statement**

*This place covers:*

Illustrative example of subject matter classified in this group:

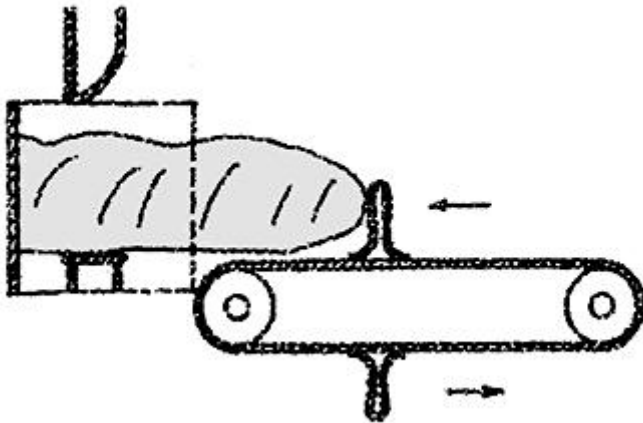

## **B65G 15/46**

**formed with guides**

### **Definition statement**

*This place covers:*

Illustrative example of subject matter classified in this group:

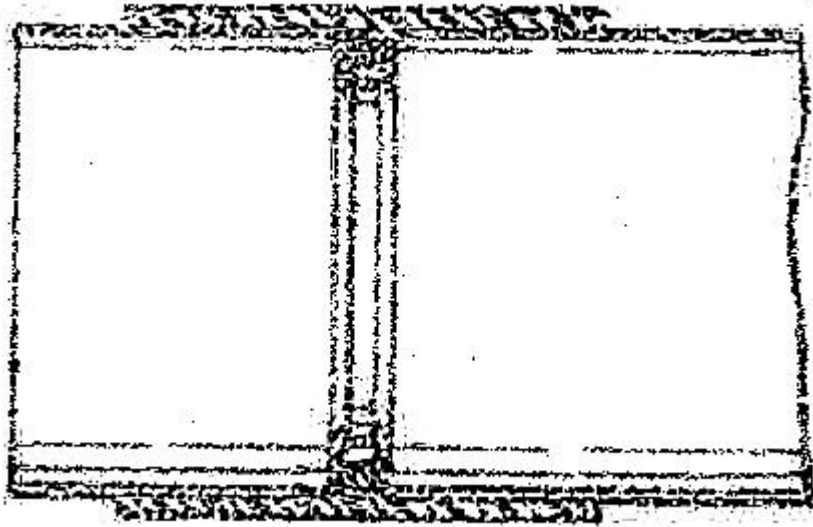

## B65G 15/48

metallic

### Definition statement

*This place covers:*

Illustrative example of subject matter classified in this group:

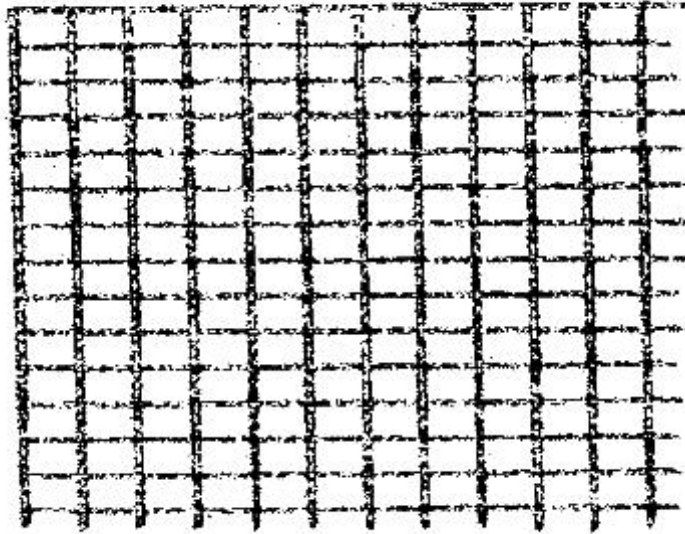

## B65G 15/50

Endless load-carriers consisting of a series of parallel ropes or belt strips

### Definition statement

*This place covers:*

Illustrative example of subject matter classified in this group:

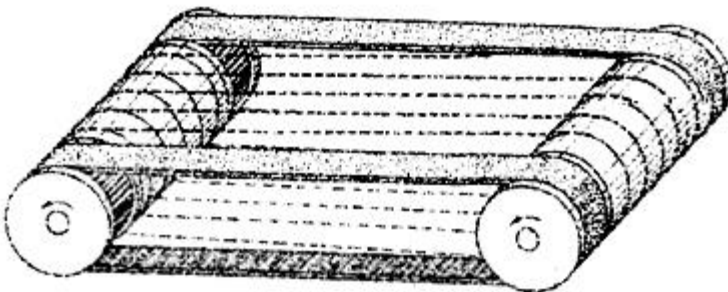

## References

### Limiting references

*This place does not cover:*

Parallel ropes	<a href="#">B65G 15/105</a>
Parallel belts building a common surface (otherwise)	<a href="#">B65G 15/12</a>

## B65G 15/52

**interconnected by transverse slats**

### Definition statement

*This place covers:*

Illustrative example of subject matter classified in this group:

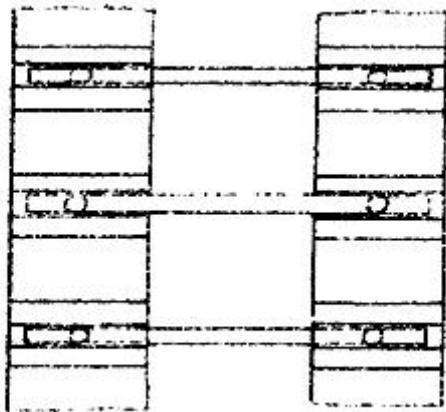

## References

### Limiting references

*This place does not cover:*

Harvesting machines	<a href="#">A01D 17/00</a>
---------------------	----------------------------



## B65G 15/54

Endless load-carriers made of interwoven ropes or wires

### Definition statement

*This place covers:*

Illustrative example of subject matter classified in this group:

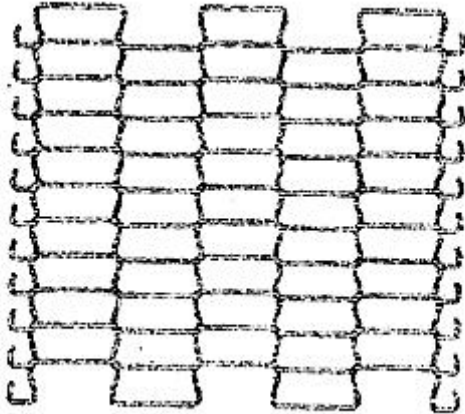

## B65G 15/56

with edge-protecting or reinforcing means

### Definition statement

*This place covers:*

Illustrative example of subject matter classified in this group:



## B65G 15/58

with means for holding or retaining the loads in fixed position, e.g. magnetic

### Definition statement

*This place covers:*

Also for belts with suction cups when the vacuum is created by each suction cup.

"Fixed" position requires that there is no movement of the load at all.

Illustrative example of subject matter classified in this group:

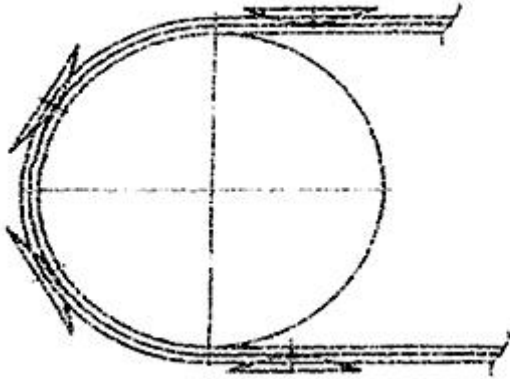

## References

### Informative references

Attention is drawn to the following places, which may be of interest for search:

"Ridges" that hold an article	<a href="#">B65G 15/42</a>
Load carriers resting on the traction element (chain or chain pair), with means for lifting the load carrier from the chain and stopping temporarily the movement of the load carrier.	<a href="#">B65G 17/002</a>
Suction retaining means (vacuum is created in plenum by the belt surface)	<a href="#">B65G 21/2027</a>

## B65G 15/60

### Arrangements for supporting or guiding belts, e.g. by fluid jets

#### Definition statement

*This place covers:*

Illustrative example of subject matter classified in this group:

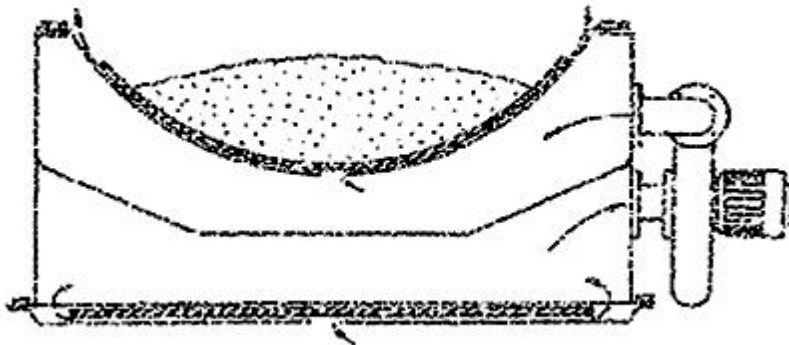

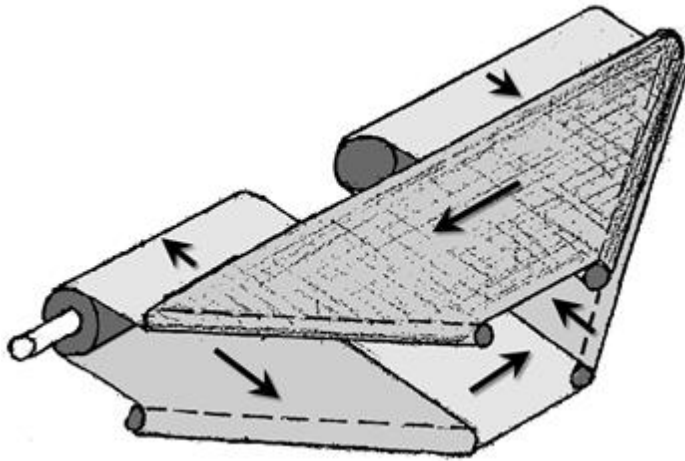

## References

### Informative references

Attention is drawn to the following places, which may be of interest for search:

Construction of rollers or supports thereof	<a href="#">B65G 39/00</a>
Rollers mounted on framework	<a href="#">B65G 39/12</a>
Rolls, drums, discs, or the like	<a href="#">F16C 13/00</a>

## B65G 15/62

### Guides for sliding belts

#### Definition statement

*This place covers:*

When the belt is sliding on the support (no rollers)

Illustrative example of subject matter classified in this group:

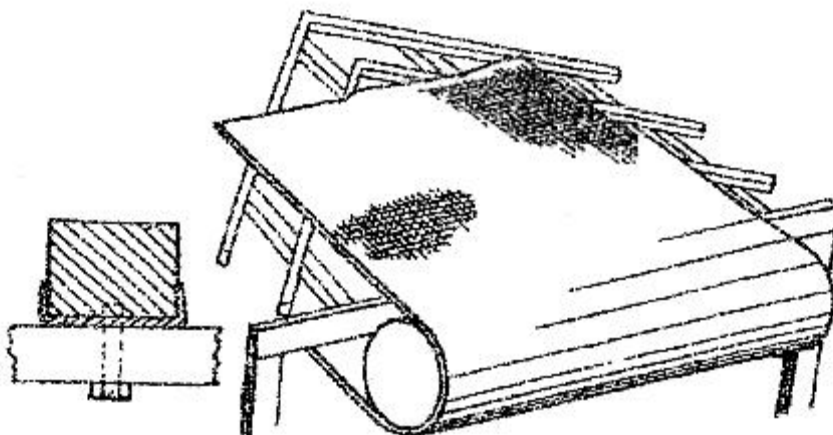

## References

### *Informative references*

Attention is drawn to the following places, which may be of interest for search:

Absorbing impacts in the way of the bulk feeder	<a href="#">B65G 21/2081</a>
-------------------------------------------------	------------------------------

## B65G 15/64

for automatically maintaining the position of the belts

### Definition statement

*This place covers:*

Illustrative example of subject matter classified in this group:

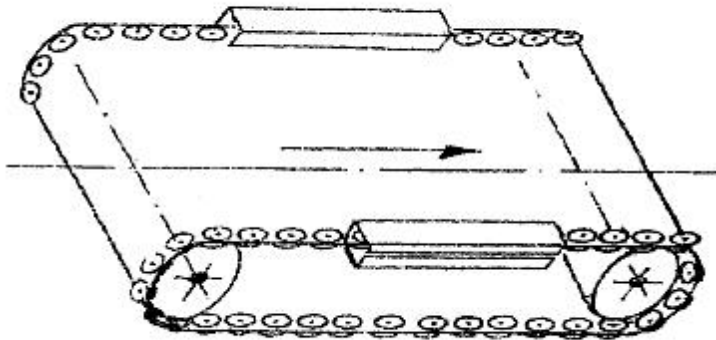

## References

### *Informative references*

Attention is drawn to the following places, which may be of interest for search:

By means of rollers	<a href="#">B65G 39/16</a>
Toothed belt wheels	<a href="#">F16H 55/171</a>

## B65G 17/00

**Conveyors having an endless traction element, e.g. a chain, transmitting movement to a continuous or substantially-continuous load-carrying surface or to a series of individual load-carriers; Endless-chain conveyors in which the chains form the load-carrying surface**

### References

#### Application-oriented references

*Examples of places where the subject matter of this place is covered when specially adapted, used for a particular purpose, or incorporated in a larger system:*

Escalators or paternosters neither combined nor associated with loading or unloading apparatus	<a href="#">B66B 9/00</a>
------------------------------------------------------------------------------------------------	---------------------------

#### Informative references

*Attention is drawn to the following places, which may be of interest for search:*

Conveyors comprising an impeller or a series of impellers carried by an endless traction element and arranged to move articles or materials over a supporting surface or underlying material	<a href="#">B65G 19/00</a>
Feeding or discharging conveyors by devices incorporated in, or operatively associated with conveyors	<a href="#">B65G 47/00</a>
Loading or unloading	<a href="#">B65G 65/00</a>
Advertising	<a href="#">B65G 2207/04</a>
Devices controlling the relative position of articles	<a href="#">B65G 2811/061</a> - <a href="#">B65G 2811/0668</a> , <a href="#">B65G 2812/02267</a> - <a href="#">B65G 2812/02277</a>
Chains, cables or the like	<a href="#">B65G 2812/02326</a> - <a href="#">B65G 2812/02396</a>
With load-carrying surfaces supported by traction means	<a href="#">B65G 2812/02415</a> - <a href="#">B65G 2812/02683</a>
Bucket elevators for bulk material	<a href="#">B65G 2812/02742</a> - <a href="#">B65G 2812/02851</a>
Tools for repairing chains	<a href="#">B21L 21/00</a>
Railway systems, detachable load-carriers on rails	<a href="#">B61B</a>
Escalators or paternosters neither combined nor associated with loading or unloading apparatus	<a href="#">B66B 9/00</a>

**B65G 17/002**

{comprising load carriers resting on the traction element}

**Definition statement**

*This place covers:*

Illustrative example of subject matter classified in this group:

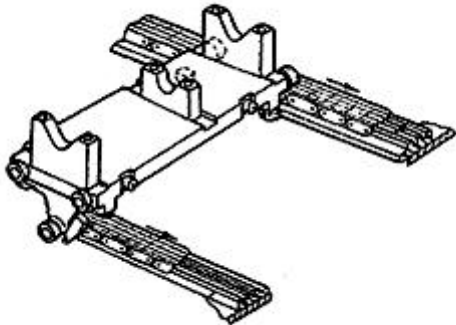
**References****Informative references**

*Attention is drawn to the following places, which may be of interest for search:*

Kinds of mechanical conveyors comprising a load-carrier moving along a path	<a href="#">B65G 35/06</a>
-----------------------------------------------------------------------------	----------------------------

**B65G 17/005**

{comprising individual load carriers which are movably mounted ([B65G 17/16](#) takes precedence)}

**Definition statement**

*This place covers:*

Illustrative example of subject matter classified in this group:

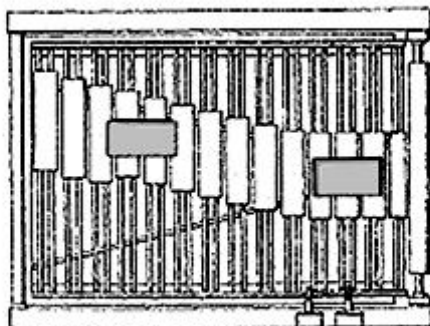

## References

### Limiting references

*This place does not cover:*

Devices having endless travelling belts or chains equipped with article-engaging elements	<a href="#">B65G 47/841</a>
-------------------------------------------------------------------------------------------	-----------------------------

## B65G 17/007

{for conveying the load on the lower run or on both upper and lower runs of the conveyor}

### Definition statement

*This place covers:*

Illustrative example of subject matter classified in this group:

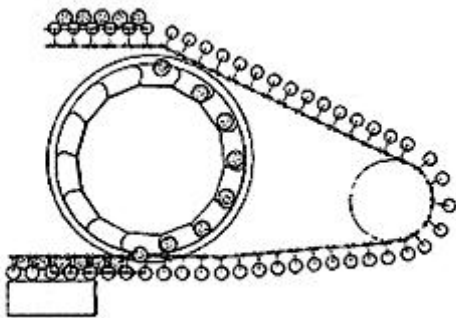

## B65G 17/04

the belt having loops forming load-receiving pockets

### Definition statement

*This place covers:*

Illustrative example of subject matter classified in this group:

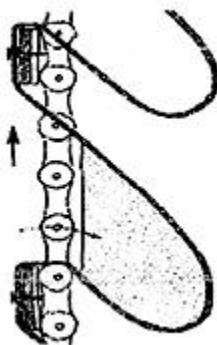

**B65G 17/061**

{the load carrying surface being formed by profiles, rods, bars, rollers or the like attached to a single traction element ([B65G 17/24](#) takes precedence)}

**Definition statement**

*This place covers:*

Illustrative example of subject matter classified in this group:

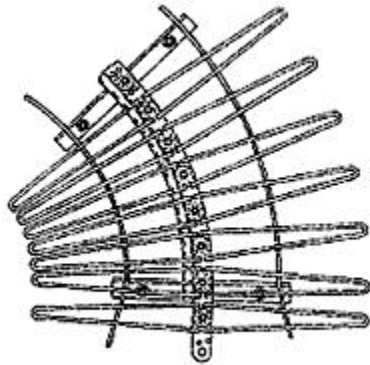
**References****Limiting references**

*This place does not cover:*

A series of rollers which are moved	<a href="#">B65G 17/24</a>
-------------------------------------	----------------------------

**B65G 17/062**

{the profiles, rods, bars, rollers or the like being interconnected by a mesh or grid-like structure}

**Definition statement**

*This place covers:*

Illustrative example of subject matter classified in this group:

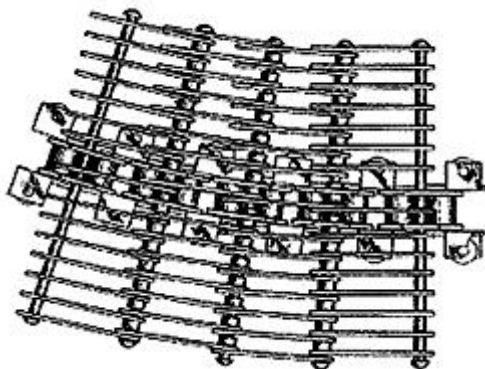



## B65G 17/063

{the load carrying surface being formed by profiles, rods, bars, rollers or the like attached to more than one traction element ([B65G 17/24](#) takes precedence)}

### Definition statement

*This place covers:*

Illustrative example of subject matter classified in this group:

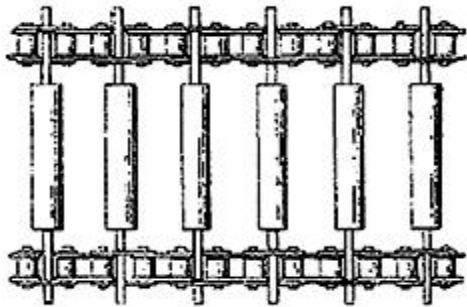

## B65G 17/064

{the profiles, rods, bars, rollers or the like being interconnected by a mesh or grid-like structure}

### Definition statement

*This place covers:*

Illustrative example of subject matter classified in this group:

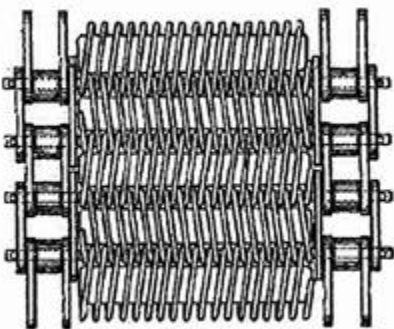

## B65G 17/065

{the load carrying surface being formed by plates or platforms attached to a single traction element}

### Definition statement

*This place covers:*

Illustrative example of subject matter classified in this group:

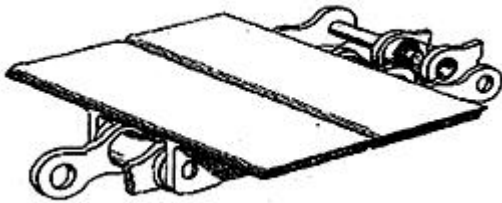

## B65G 17/066

{specially adapted to follow a curved path (for individual load carriers [B65G 17/22](#))}

### Definition statement

*This place covers:*

Illustrative example of subject matter classified in this group:

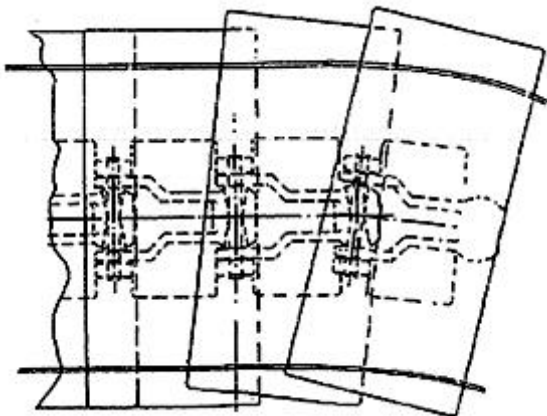

## B65G 17/067

{the load carrying surface being formed by plates or platforms attached to more than one traction element}

### Definition statement

*This place covers:*

Illustrative example of subject matter classified in this group:

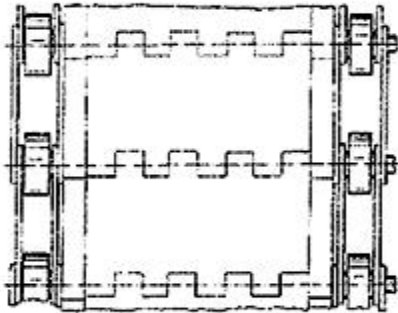

## B65G 17/068

{specially adapted to follow a curved path (for individual load carriers [B65G 17/22](#))}

### Definition statement

*This place covers:*

Illustrative example of subject matter classified in this group:

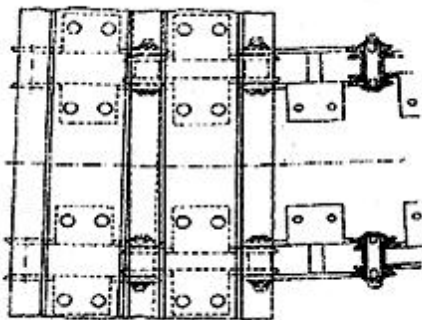

## **B65G 17/08**

**the surface being formed by the traction element**

### **Definition statement**

*This place covers:*

Illustrative example of subject matter classified in this group:

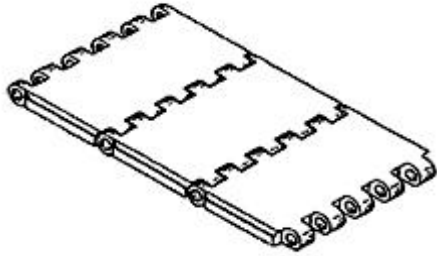

### **Special rules of classification**

Chains whereby the chain would be broken if a load carrier is removed should be classified in [B65G 17/08](#) (Otherwise [B65G 17/06](#)).

## **B65G 17/083**

**{the surface being formed by profiles, rods, bars, rollers or the like}**

### **Definition statement**

*This place covers:*

Illustrative example of subject matter classified in this group:

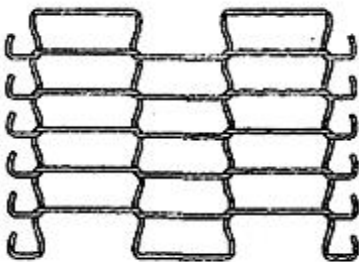

## **B65G 17/086**

{specially adapted to follow a curved path (for individual load carriers [B65G 17/22](#))}

### **Definition statement**

*This place covers:*

Illustrative example of subject matter classified in this group:

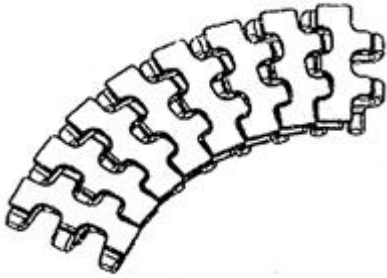

## **B65G 17/10**

the surface forming a longitudinal trough

### **Definition statement**

*This place covers:*

Illustrative example of subject matter classified in this group:

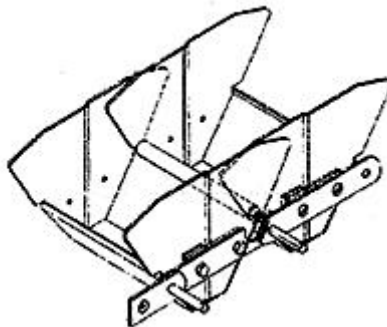

## B65G 17/12

comprising a series of individual load-carriers fixed, or normally fixed, relative to traction element

### Definition statement

*This place covers:*

Illustrative example of subject matter classified in this group:

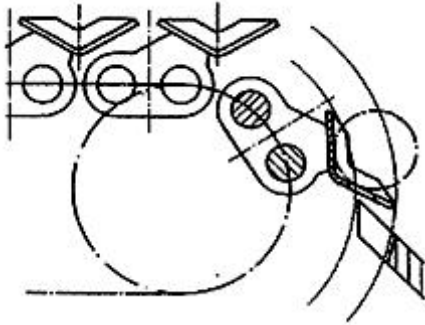

## B65G 17/123

{arranged to keep the load-carriers horizontally during at least a part of the conveyor run}

### Definition statement

*This place covers:*

Illustrative example of subject matter classified in this group:

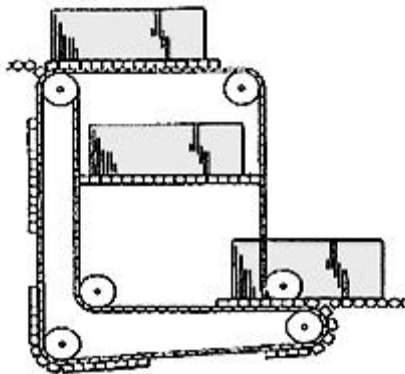

**B65G 17/126****{Bucket elevators}****Definition statement***This place covers:*

Illustrative example of subject matter classified in this group:

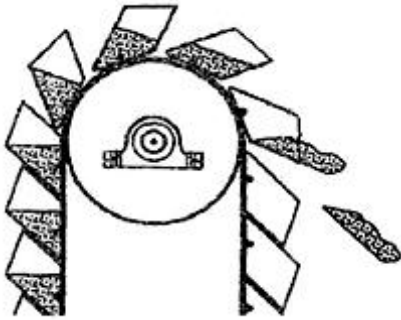
**References****Informative references***Attention is drawn to the following places, which may be of interest for search:*

For details of the bucket	<a href="#">B65G 17/36</a>
For means for fastening the bucket to the chain	<a href="#">B65G 17/42</a>
For details of the means to load/unload the buckets	<a href="#">B65G 47/58</a>

**B65G 17/14****with two spaced connections to traction element****Definition statement***This place covers:*

Illustrative example of subject matter classified in this group:

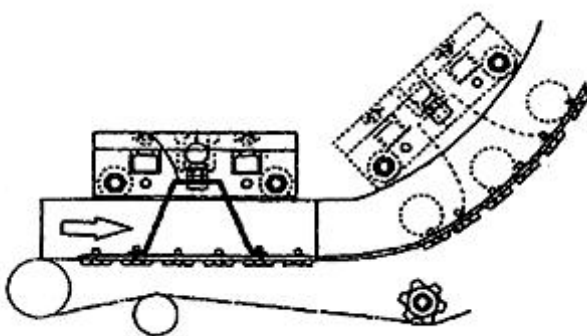

**B65G 17/16**

comprising individual load-carriers which are pivotally mounted, e.g. for free-swinging movement (guides inverting or tilting load-carriers for emptying {[B65G 47/38](#); [B65G 17/20](#) takes precedence})

**Definition statement**

*This place covers:*

Illustrative example of subject matter classified in this group:

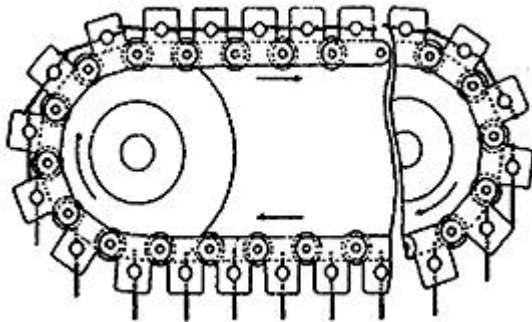
**References****Informative references**

Attention is drawn to the following places, which may be of interest for search:

Suspended load-carriers	<a href="#">B65G 1/127</a>
-------------------------	----------------------------

**B65G 17/18**

and move in contact with a guiding surface

**Definition statement**

*This place covers:*

Illustrative example of subject matter classified in this group:

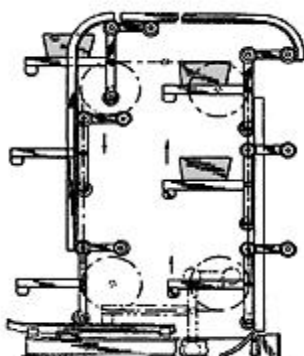



**B65G 17/20**

comprising load-carriers suspended from overhead traction chains

**Definition statement**

*This place covers:*

Illustrative example of subject matter classified in this group:

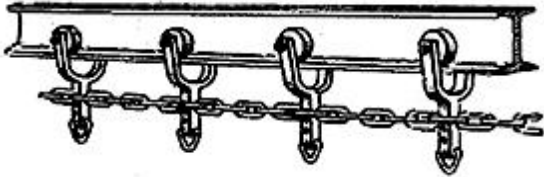
**References****Informative references**

*Attention is drawn to the following places, which may be of interest for search:*

Rollers attached to moving belts or chains	<a href="#">B65G 39/20</a>
Conveyors for slaughterhouses	<a href="#">A22B 7/001</a>

**B65G 17/22**

with oppositely-moving parts of the conveyor located in a common plane {and being formed by individual load carriers only}

**Definition statement**

*This place covers:*

Illustrative example of subject matter classified in this group:

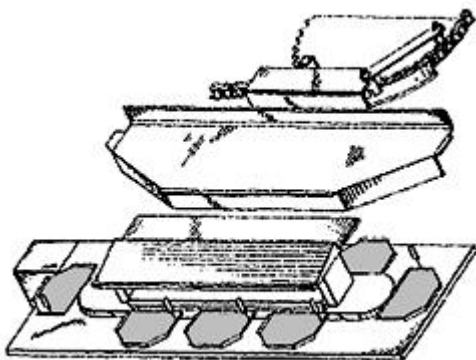

**B65G 17/24**

comprising a series of rollers which are moved {, e.g. over a supporting surface, by the traction element to effect conveyance of loads or load-carriers}

**Definition statement**

*This place covers:*

Illustrative example of subject matter classified in this group:

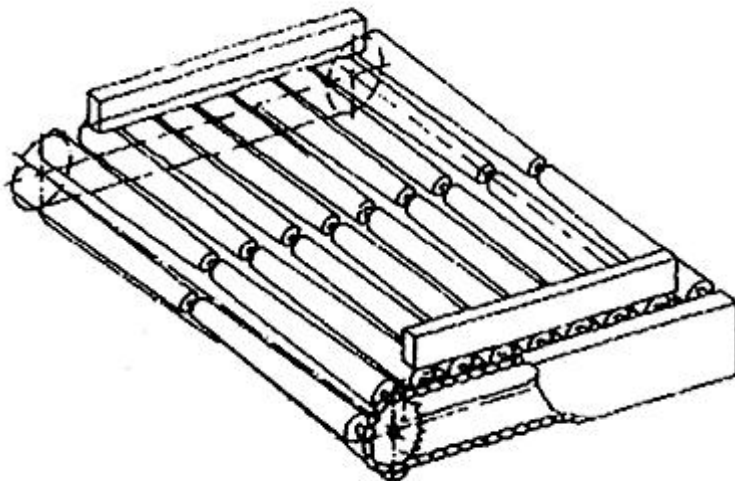
**B65G 17/26**

comprising a series of co-operating units, e.g. interconnected by pivots

**Definition statement**

*This place covers:*

Illustrative example of subject matter classified in this group:

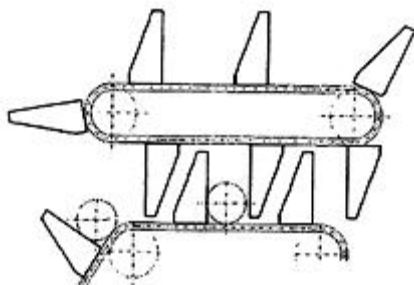
**References****Informative references**

*Attention is drawn to the following places, which may be of interest for search:*

For belts	<a href="#">B65G 15/10</a>
Conveying means adjustable for different sizes of articles	<a href="#">B65B 59/005</a>

**B65G 17/32****Individual load-carriers****Definition statement**

*This place covers:*

Illustrative example of subject matter classified in this group:

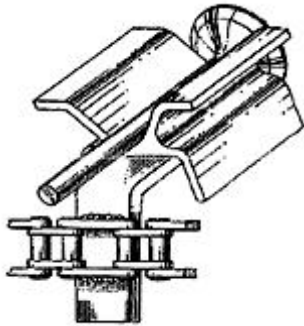
**References****Informative references**

*Attention is drawn to the following places, which may be of interest for search:*

Control	<a href="#">B65G 17/48</a>
For conveying pucks	<a href="#">B65G 2201/0258</a> , <a href="#">B65G 2201/0261</a>
Related to pucks (spring pressure)	<a href="#">B65D 25/10</a> , <a href="#">B65D 25/101</a>

**B65G 17/323****{Grippers, e.g. suction or magnetic}****Definition statement**

*This place covers:*

Illustrative example of subject matter classified in this group:

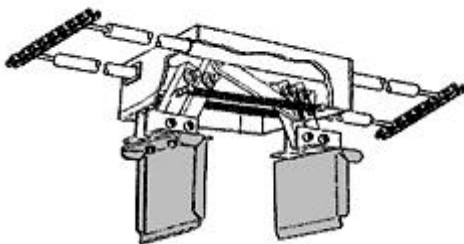

## B65G 17/326

{Clamps, constituted by articulated chain links}

### Definition statement

*This place covers:*

Illustrative example of subject matter classified in this group:

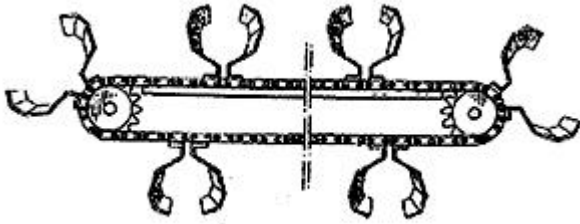

## B65G 17/34

having flat surfaces, e.g. platforms, grids, forks

### Definition statement

*This place covers:*

Illustrative example of subject matter classified in this group:

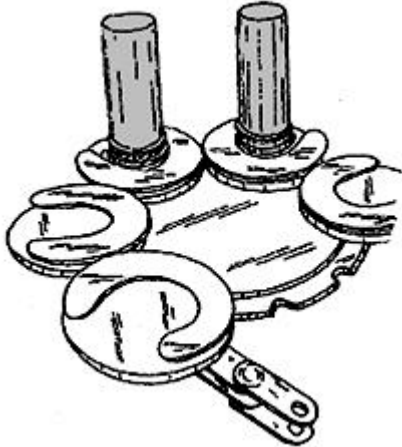

## B65G 17/345

{the surfaces being equipped with a conveyor}

### Definition statement

*This place covers:*

Illustrative example of subject matter classified in this group:

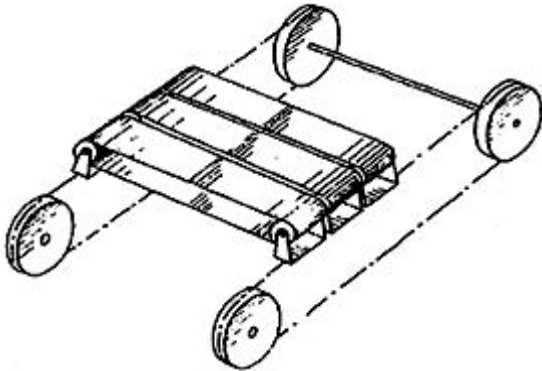

## B65G 17/36

having concave surfaces, e.g. buckets

### Definition statement

*This place covers:*

Illustrative example of subject matter classified in this group:

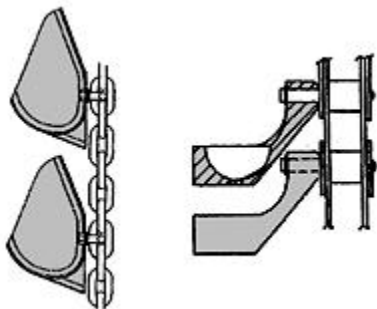

**B65G 17/365****{having open bottom buckets}****Definition statement***This place covers:*

Illustrative example of subject matter classified in this group:

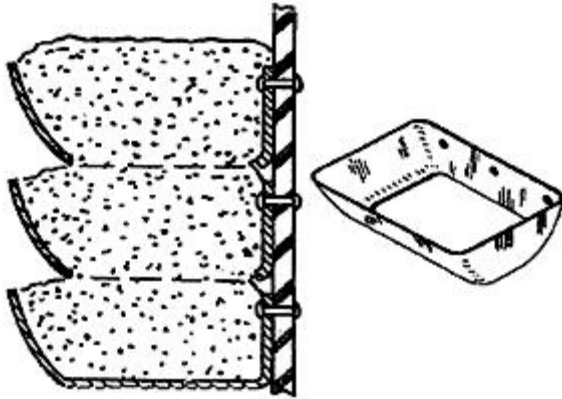
**B65G 17/38****Chains or like traction elements (drive chains [F16G 13/00](#)); Connections between traction elements and load-carriers****Definition statement***This place covers:*

Illustrative example of subject matter classified in this group:

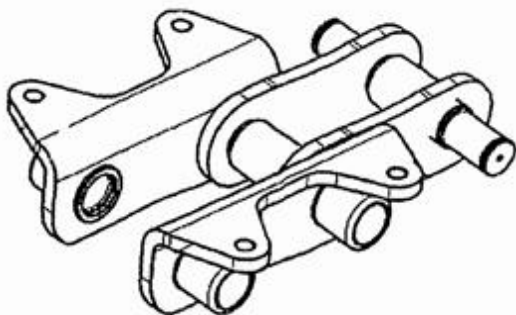
**References****Limiting references***This place does not cover:*

Drive chains	<a href="#">F16G 13/00</a>
--------------	----------------------------

**Informative references***Attention is drawn to the following places, which may be of interest for search:*

Details of the chain link	<a href="#">B65G 17/06</a>
---------------------------	----------------------------

Self-lubricating chain links
------------------------------

<a href="#">B65G 45/08</a>
----------------------------

## B65G 17/385

{adapted to follow three-dimensionally curved paths}

### Definition statement

*This place covers:*

Illustrative example of subject matter classified in this group:

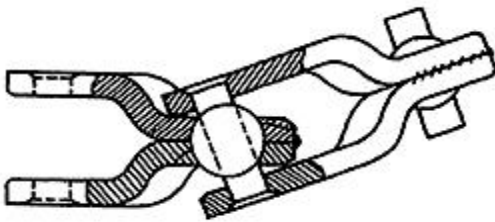

## B65G 17/40

Chains acting as load-carriers

### Definition statement

*This place covers:*

Illustrative example of subject matter classified in this group:

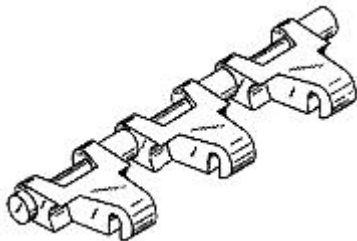

## References

### Informative references

*Attention is drawn to the following places, which may be of interest for search:*

Details of the chain link
---------------------------

<a href="#">B65G 17/08</a>
----------------------------

## B65G 17/42

### Attaching load carriers to traction elements

#### Definition statement

*This place covers:*

Illustrative example of subject matter classified in this group:

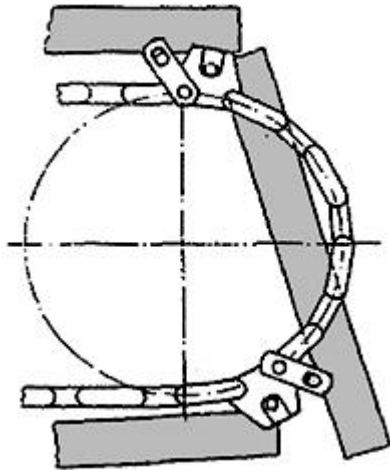

## B65G 17/44

### by means excluding relative movements

#### Definition statement

*This place covers:*

Illustrative example of subject matter classified in this group:

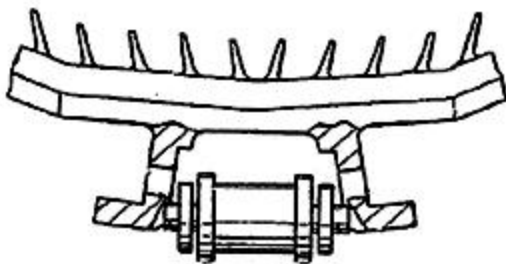



**B65G 17/46**

Means for holding or retaining the loads in fixed position on the load-carriers, e.g. magnetic

**Definition statement**

*This place covers:*

Illustrative example of subject matter classified in this group:

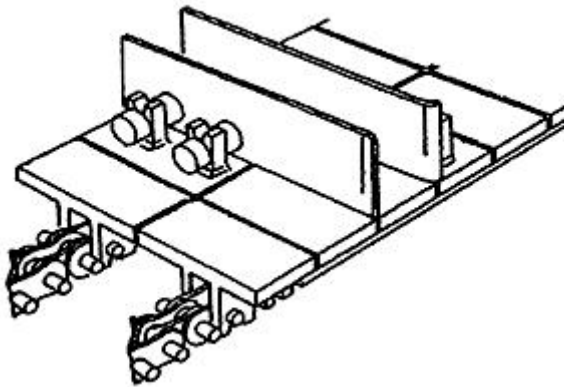
**B65G 17/48**

Controlling attitudes of load-carriers during movement ({[B65G 17/18](#) takes precedence;}) guides [B65G 21/20](#); inverting or tilting load carriers to discharge contents [B65G 47/38](#))

**Definition statement**

*This place covers:*

Illustrative example of subject matter classified in this group:

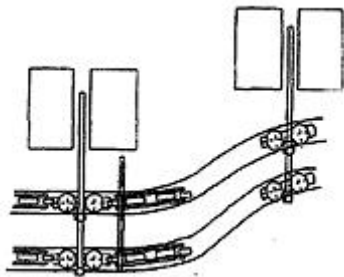

**B65G 17/485****{the load carriers being suspended}****Definition statement***This place covers:*

Illustrative example of subject matter classified in this group:

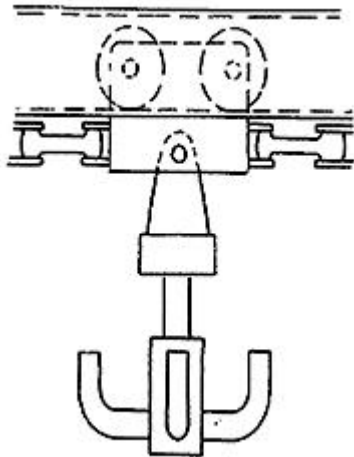
**Special rules of classification**Including means for controlling the altitude of the road carriers (otherwise: [B65G 17/20](#)).**B65G 19/00****Conveyors comprising an impeller or a series of impellers carried by an endless traction element and arranged to move articles or materials over a supporting surface or underlying material, e.g. endless scraper conveyors****References****Informative references***Attention is drawn to the following places, which may be of interest for search:*

Feeding or discharging conveyors by devices incorporated in, or operatively associated with, conveyors	<a href="#">B65G 47/00</a>
Loading or unloading	<a href="#">B65G 65/00</a>

**Special rules of classification**

In this group the following Indexing Codes are used only for search:

[B65G 2812/02861](#) - [B65G 2812/0298](#)

**B65G 19/02**

for articles, e.g. for containers

**Definition statement**

*This place covers:*

Illustrative example of subject matter classified in this group:

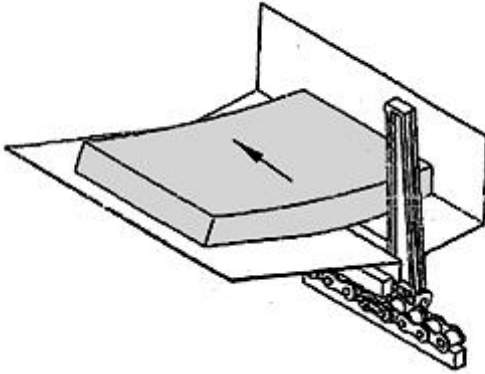
**References****Informative references**

Attention is drawn to the following places, which may be of interest for search:

Conveyors for car wash systems	<a href="#">B60S 3/004</a>
Power and free systems for (suspended) railway systems	<a href="#">B61B 10/00</a>

**B65G 19/025**

{for suspended articles}

**Definition statement**

*This place covers:*

Illustrative example of subject matter classified in this group:

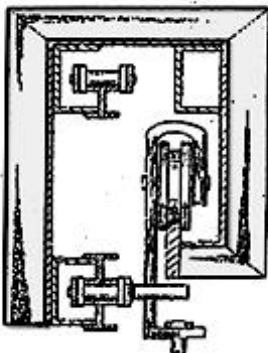

## References

### *Informative references*

*Attention is drawn to the following places, which may be of interest for search:*

Power and free systems for (suspended) railway systems)	<a href="#">B61B 10/00</a>
---------------------------------------------------------	----------------------------

## B65G 19/04

**for moving bulk material in open troughs or channels**

### Definition statement

*This place covers:*

Illustrative example of subject matter classified in this group:

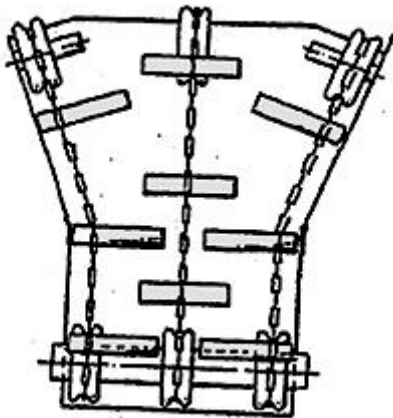

**B65G 19/06**

the impellers being scrapers similar in size and shape to the cross-section of the trough or channel

**Definition statement**

*This place covers:*

Illustrative example of subject matter classified in this group:

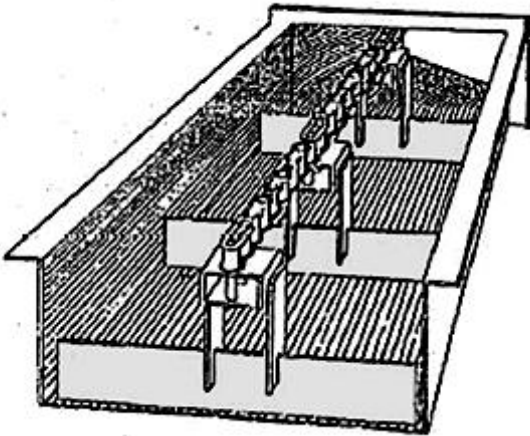
**B65G 19/08**

and attached to a single belt, rope or chain

**Definition statement**

*This place covers:*

Illustrative example of subject matter classified in this group:

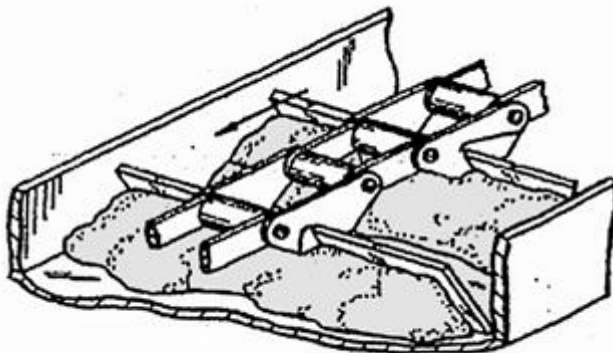
**References****Informative references**

Attention is drawn to the following places, which may be of interest for search:

Attachment of impellers to traction element	<a href="#">B65G 19/24</a>
---------------------------------------------	----------------------------

**B65G 19/10**

and attached to a pair of belts, ropes or chains

**Definition statement**

*This place covers:*

Illustrative example of subject matter classified in this group:

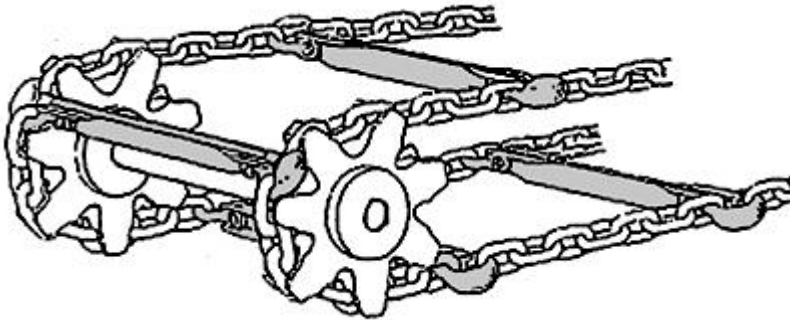
**References****Informative references**

*Attention is drawn to the following places, which may be of interest for search:*

Attachment of impellers to traction element	<a href="#">B65G 19/24</a>
---------------------------------------------	----------------------------

**B65G 19/12**

the impellers being plates having an area substantially smaller than that of the trough of channel cross-section

**Definition statement**

*This place covers:*

Illustrative example of subject matter classified in this group:

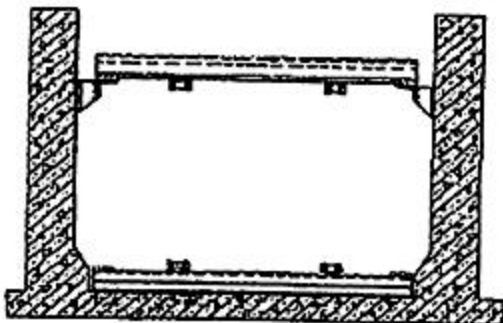

## B65G 19/14

for moving bulk material in closed conduits, e.g. tubes

### Definition statement

*This place covers:*

Illustrative example of subject matter classified in this group:

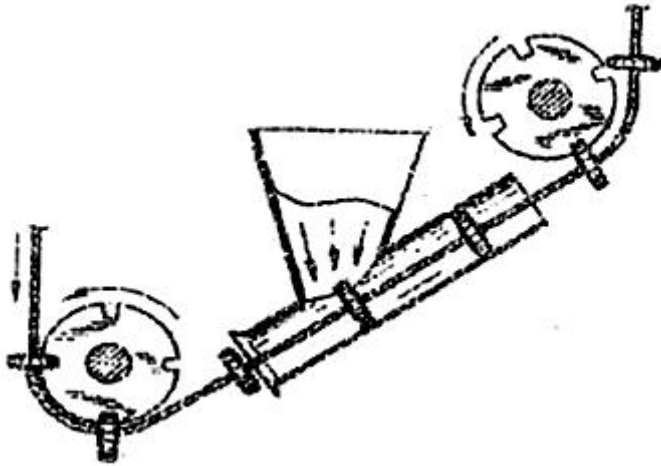

### References

#### *Informative references*

*Attention is drawn to the following places, which may be of interest for search:*

Attachment of impeller	<a href="#">B65G 19/24</a>
------------------------	----------------------------

## B65G 19/16

the impellers being elements having an area substantially smaller than that of the conduit cross-section

### Definition statement

*This place covers:*

Illustrative example of subject matter classified in this group:

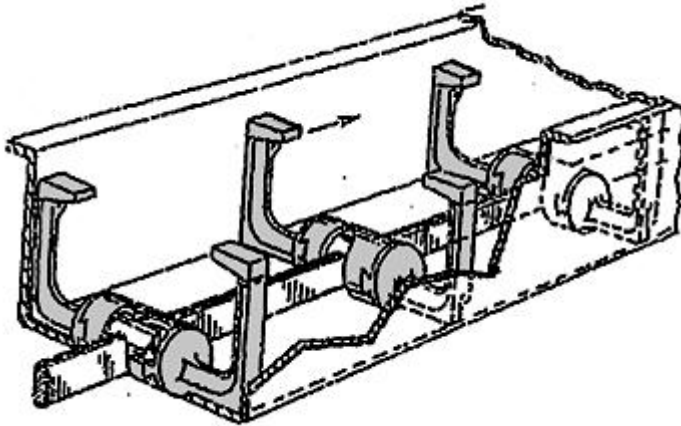

### References

#### *Informative references*

*Attention is drawn to the following places, which may be of interest for search:*

Feeding devices for stock or poultry
--------------------------------------

<a href="#">A01K 5/0208</a> , <a href="#">A01K 39/01</a>
----------------------------------------------------------



## B65G 19/165

{the impellers being endless helical springs}

### Definition statement

*This place covers:*

Illustrative example of subject matter classified in this group:

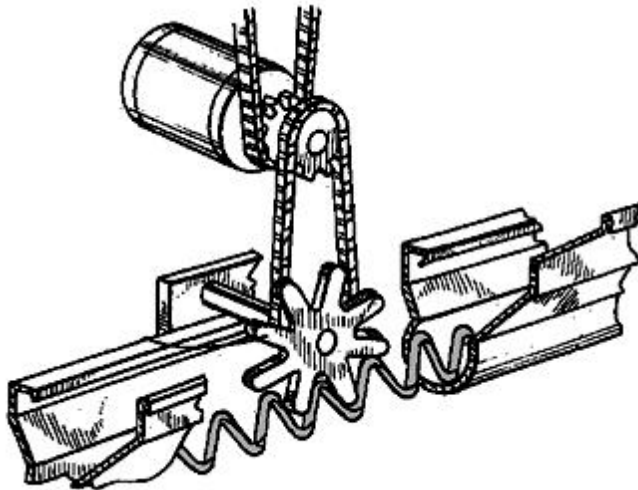

## B65G 19/20

Traction chains, ropes, or cables

### Definition statement

*This place covers:*

Illustrative example of subject matter classified in this group:

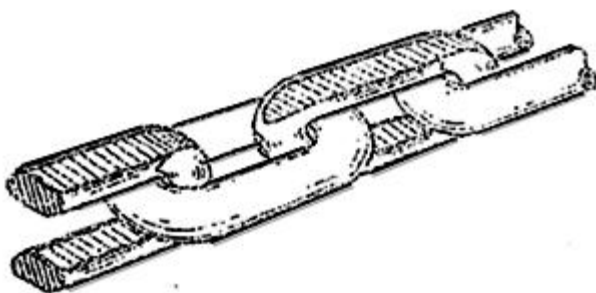

## B65G 19/205

{for article conveyors, e.g. for container conveyors}

### Definition statement

*This place covers:*

Illustrative example of subject matter classified in this group:

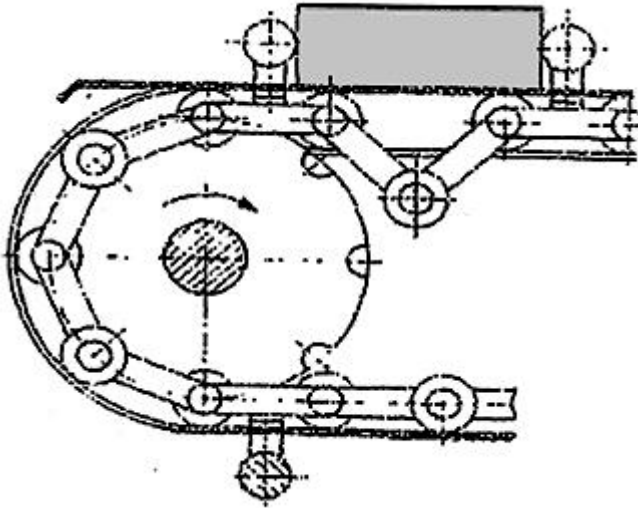

## B65G 19/22

Impellers, e.g. push-plates, scrapers; Guiding means therefor

### Definition statement

*This place covers:*

Illustrative example of subject matter classified in this group:

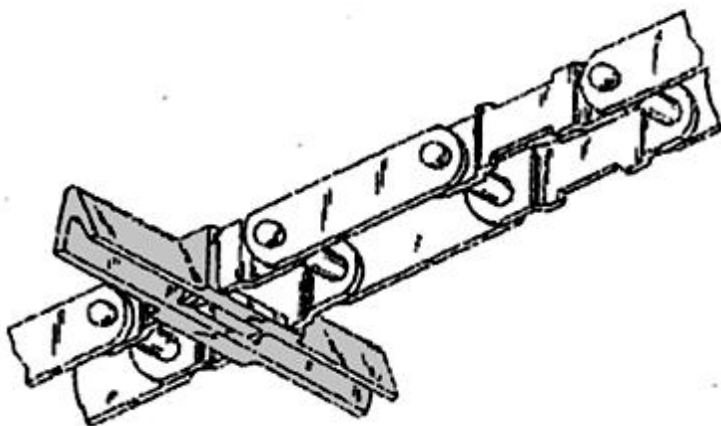

**B65G 19/225**

{for article conveyors, e.g. for container conveyors ([B65G 19/24](#) takes precedence)}

**Definition statement**

*This place covers:*

Illustrative example of subject matter classified in this group:

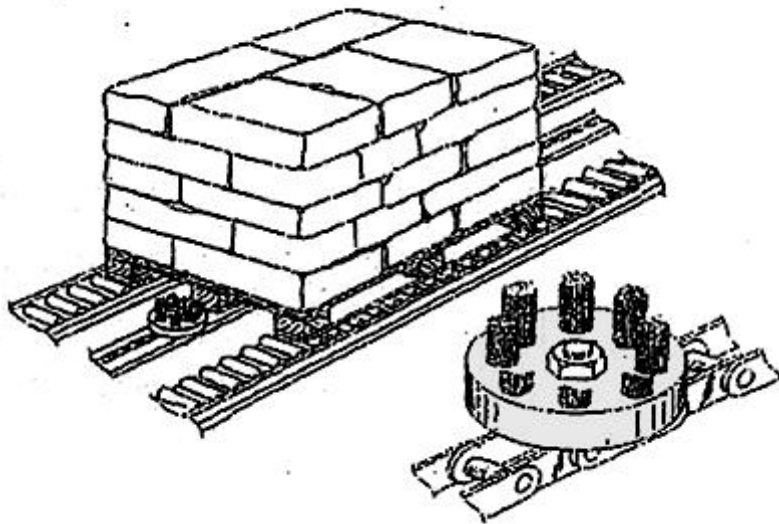
**References****Limiting references**

*This place does not cover:*

Attachment of impellers to traction element	<a href="#">B65G 19/24</a>
---------------------------------------------	----------------------------

**B65G 19/24**

**Attachment of impellers to traction element**

**Definition statement**

*This place covers:*

Illustrative example of subject matter classified in this group:

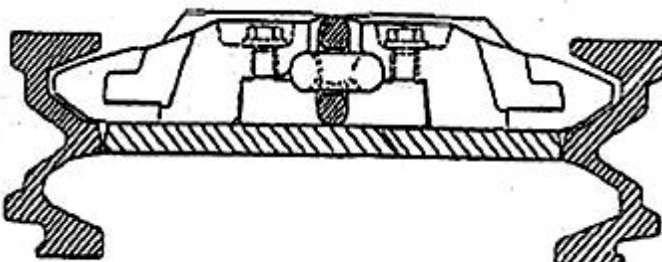

## References

### Informative references

Attention is drawn to the following places, which may be of interest for search:

Conveyors comprising an impeller and attached to a single belt, rope or chain	<a href="#">B65G 19/08</a>
Conveyors comprising an impeller and attached to a pair of belts, ropes or chains	<a href="#">B65G 19/10</a>

## B65G 19/245

{for article conveyors, e.g. for container conveyors ([B65G 19/26](#) takes precedence)}

### Definition statement

This place covers:

Illustrative example of subject matter classified in this group:

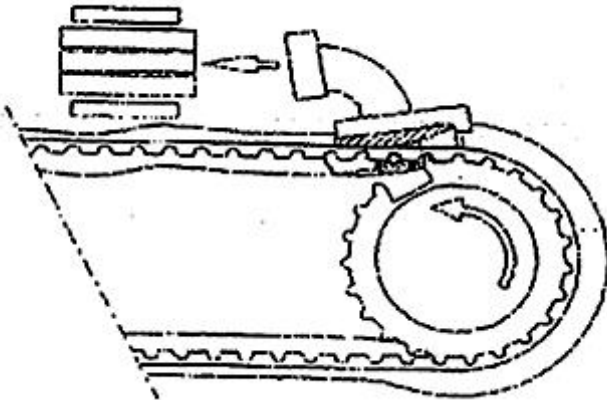

## B65G 19/26

pivotal

### Definition statement

*This place covers:*

Illustrative example of subject matter classified in this group:

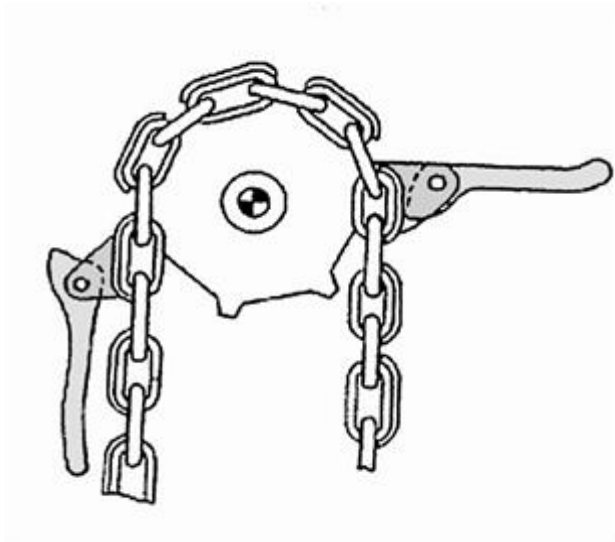

## B65G 19/265

{for article conveyors, e.g. for container conveyors}

### Definition statement

*This place covers:*

Illustrative example of subject matter classified in this group:

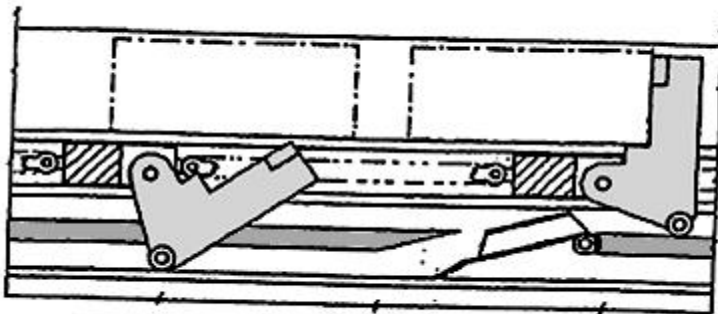

## B65G 19/28

Troughs, channels, or conduits

### Definition statement

*This place covers:*

Illustrative example of subject matter classified in this group:

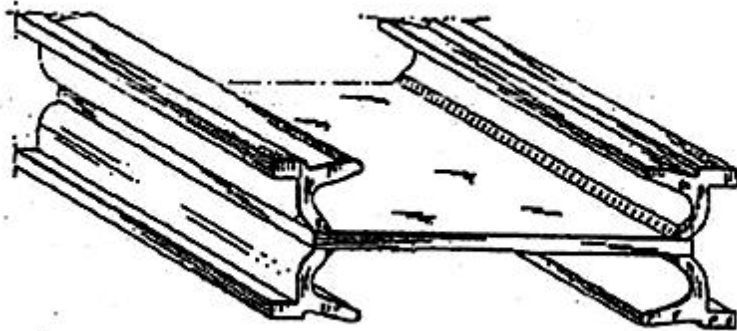

## B65G 19/282

{for article conveyors, e.g. for container conveyors ([B65G 19/30](#) takes precedence)}

### Definition statement

*This place covers:*

Illustrative example of subject matter classified in this group:

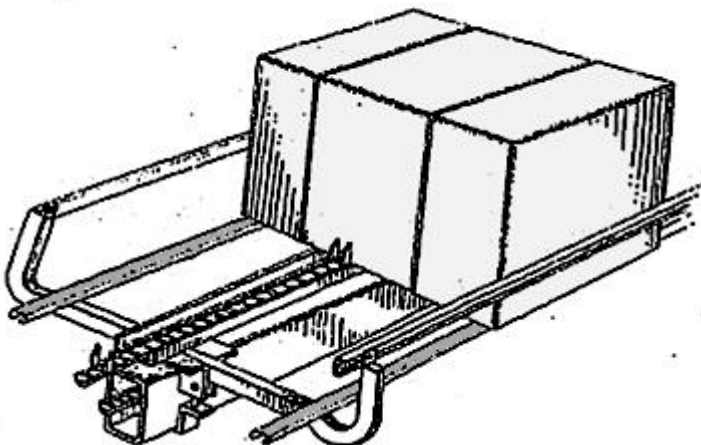

## References

### Limiting references

*This place does not cover:*

Conveyors with supporting surface modified to facilitate movement of loads	<a href="#">B65G 19/30</a>
----------------------------------------------------------------------------	----------------------------

## B65G 19/285

{with detachable or replaceable parts, e.g. replaceable wear channels  
([B65G 19/282](#) takes precedence)}

### Definition statement

*This place covers:*

Illustrative example of subject matter classified in this group:

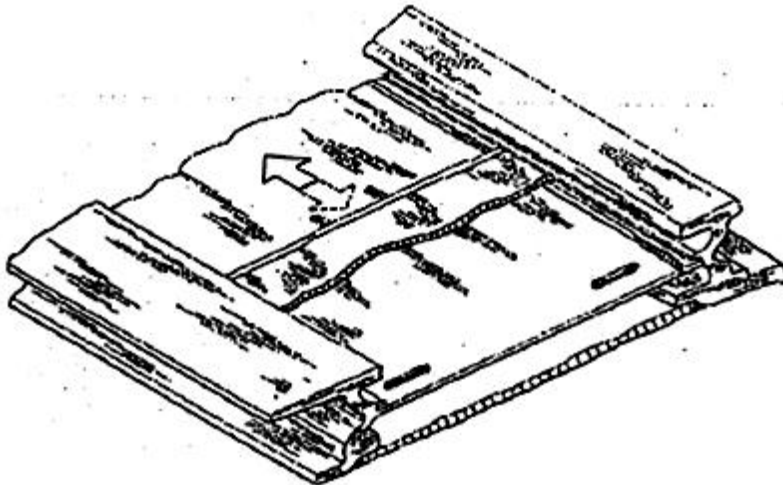



## B65G 19/287

{Coupling means for trough sections ([B65G 19/282](#) takes precedence)}

### Definition statement

*This place covers:*

Illustrative example of subject matter classified in this group:

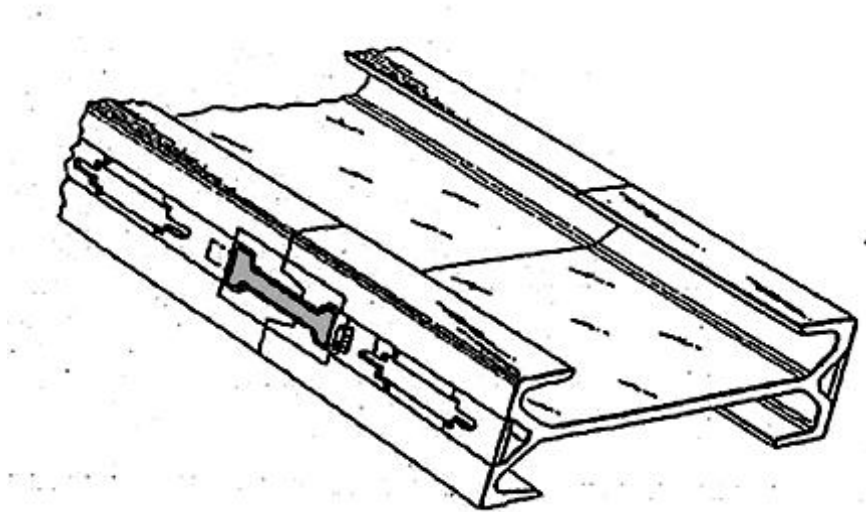

## B65G 19/30

with supporting surface modified to facilitate movement of loads, e.g. friction reducing devices

### Definition statement

*This place covers:*

Illustrative example of subject matter classified in this group:

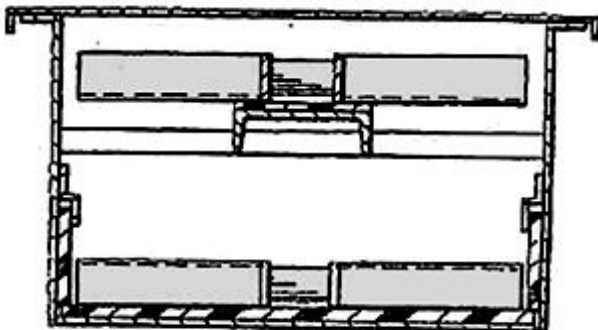



## References

### *Informative references*

Attention is drawn to the following places, which may be of interest for search:

Guides for impellers and/or traction element	<a href="#">B65G 21/2045</a>
----------------------------------------------	------------------------------

## B65G 19/303

{for article conveyors, e.g. for container conveyors}

### Definition statement

*This place covers:*

Illustrative example of subject matter classified in this group:

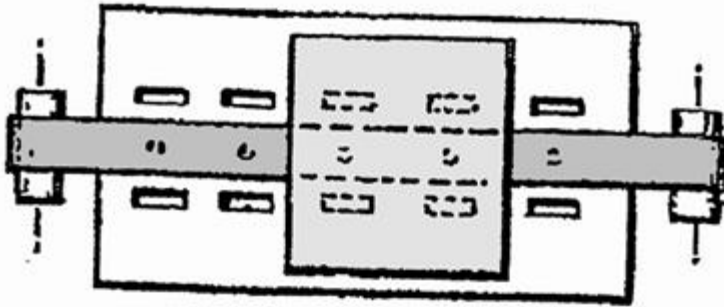

## B65G 19/306

{the supporting surface being provided with rollers}

### Definition statement

*This place covers:*

Illustrative example of subject matter classified in this group:

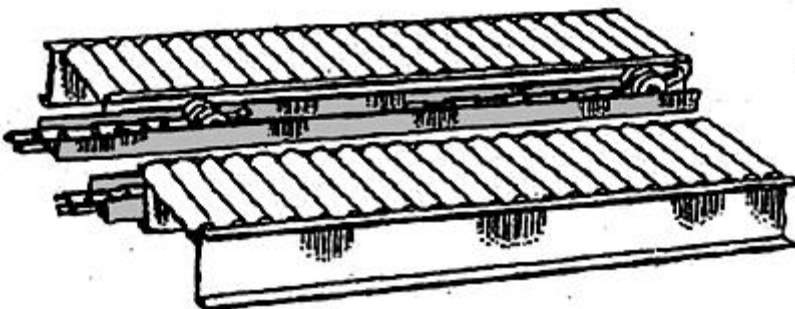

## B65G 21/00

Supporting or protective framework or housings for endless load-carriers or traction elements of belt or chain conveyors

### Definition statement

*This place covers:*

Illustrative example of subject matter classified in this group:

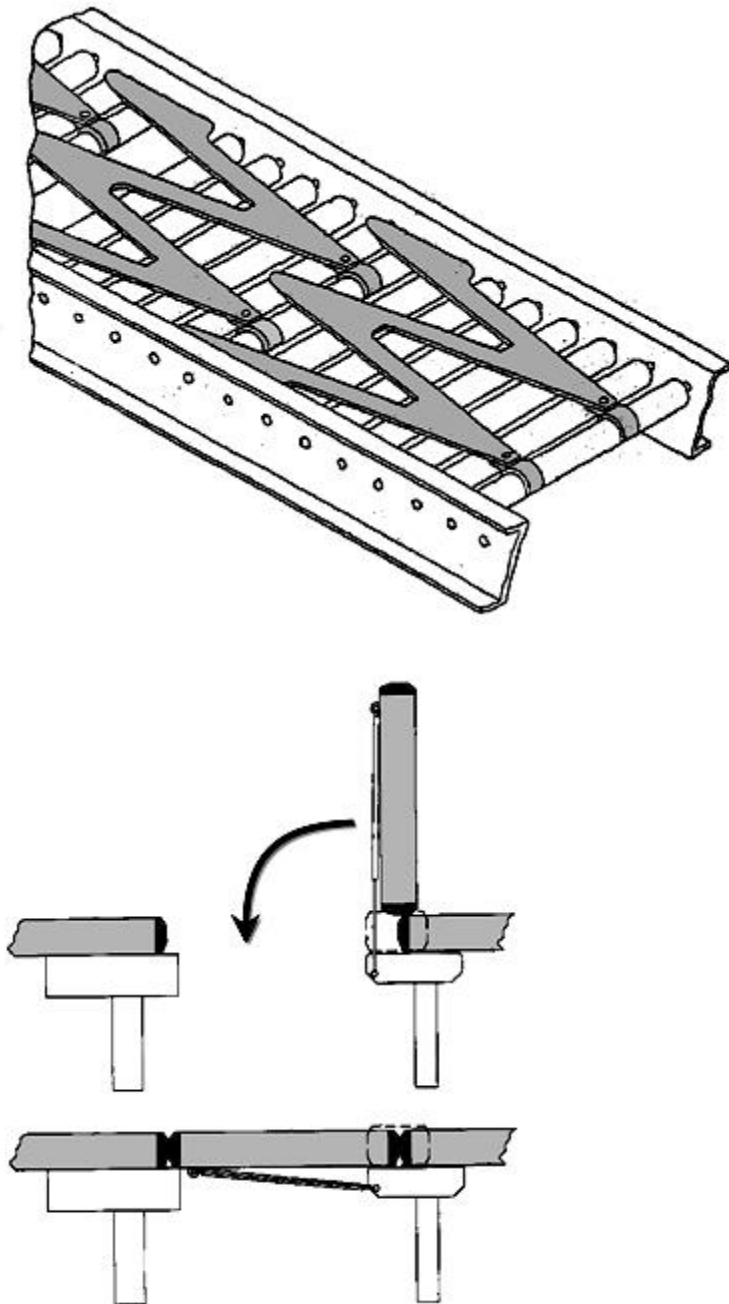

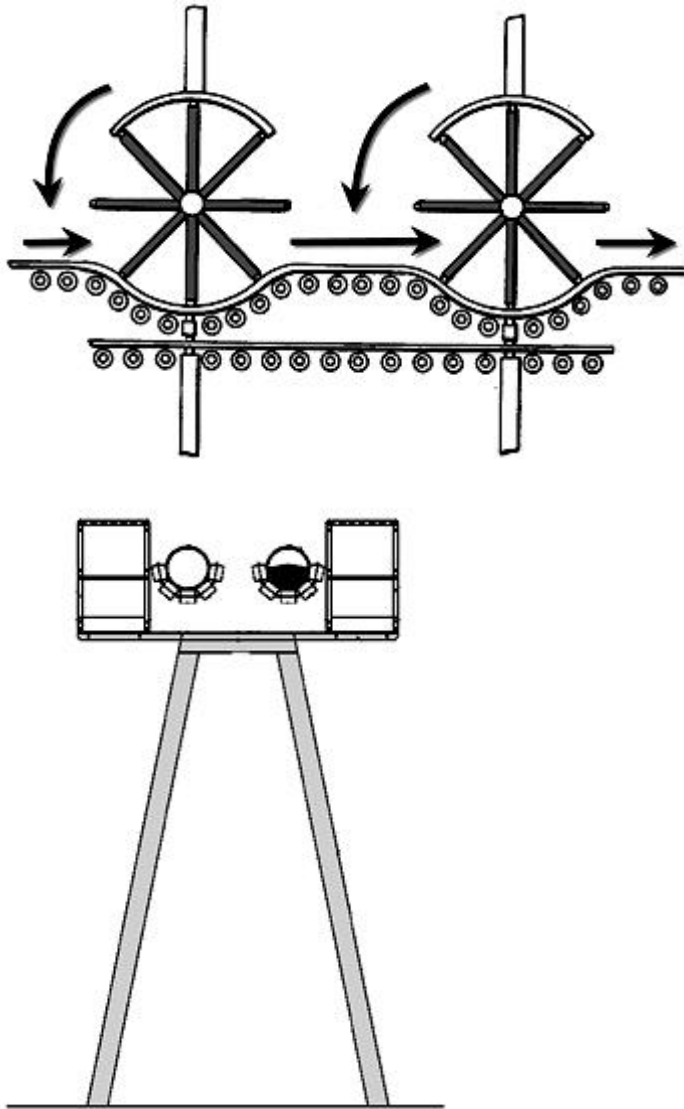

## References

### Informative references

Attention is drawn to the following places, which may be of interest for search:

Pivoting part(s) to permit passage of people	<a href="#">B65G 13/00</a>
For load carriers in jiggling conveyors	<a href="#">B65G 27/08</a>
Supporting framework or bases for conveyors as a whole	<a href="#">B65G 41/00</a>
Preventing static electricity	<a href="#">B65G 43/00</a>
Hygienic means	<a href="#">B65G 2207/26</a>
Guards for rolls in roll machines	<a href="#">F16P 1/005</a>

## B65G 21/005

{for conveyors floating on liquids}

### Definition statement

*This place covers:*

Illustrative example of subject matter classified in this group:



## B65G 21/02

consisting essentially of struts, ties, or like structural elements

### Definition statement

*This place covers:*

Illustrative example of subject matter classified in this group:

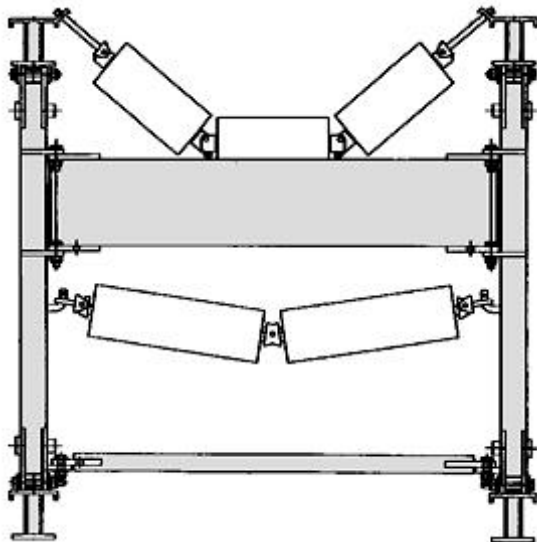

## B65G 21/04

the ties being formed by longitudinal cables or ropes

### Definition statement

*This place covers:*

Illustrative example of subject matter classified in this group:

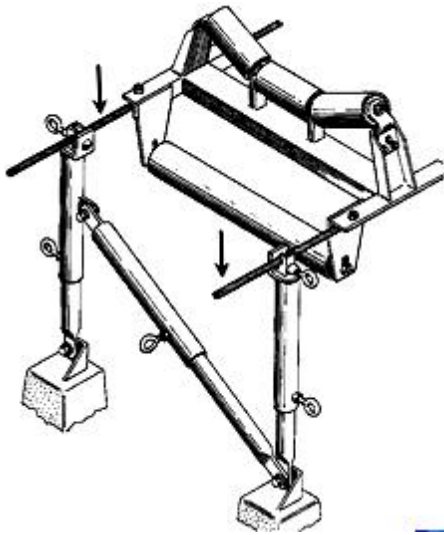

### References

#### *Informative references*

*Attention is drawn to the following places, which may be of interest for search:*

Attachment of rollers to cables	<a href="#">B65G 39/145</a>
---------------------------------	-----------------------------

## B65G 21/06

constructed to facilitate rapid assembly or dismantling

### Definition statement

*This place covers:*

Illustrative example of subject matter classified in this group:

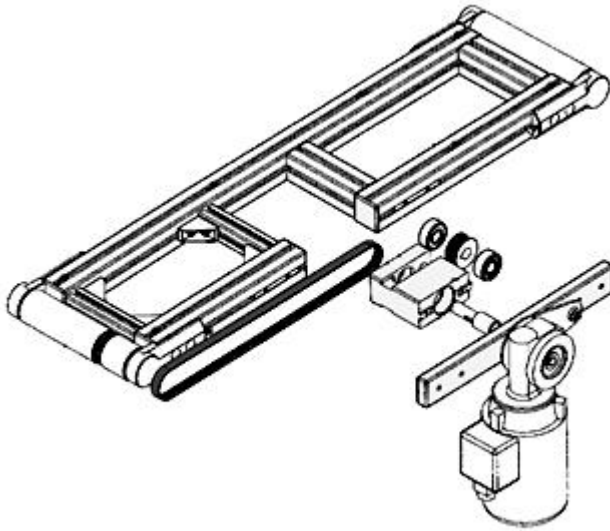

## B65G 21/08

Protective roofs or arch supports therefor

### Definition statement

*This place covers:*

Illustrative example of subject matter classified in this group:

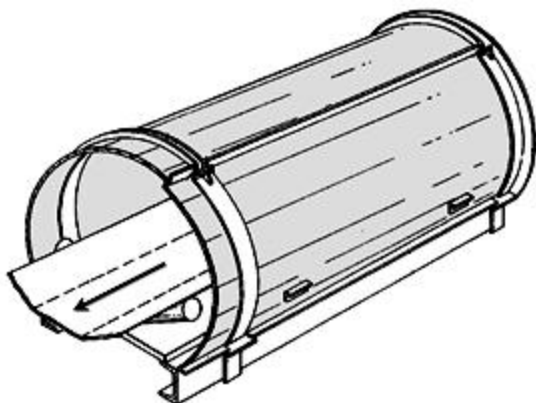

**B65G 21/10**

movable, or having interchangeable or relatively movable parts; Devices for moving framework or parts thereof

**Definition statement**

*This place covers:*

Illustrative example of subject matter classified in this group:

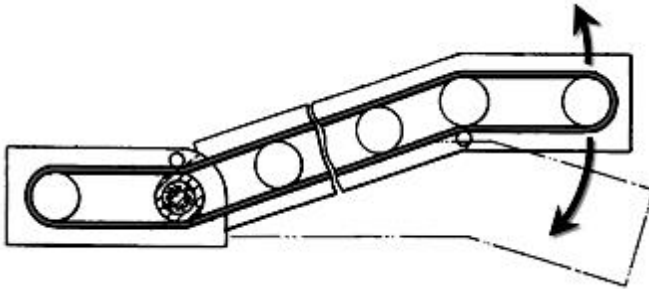
**References****Limiting references**

*This place does not cover:*

Adjustment of length	<a href="#">B65G 21/14</a>
Conveyor adjustably mounted on the frame	<a href="#">B65G 41/001</a>

**B65G 21/105**

{having demountable driving or return heads}

**Definition statement**

*This place covers:*

Illustrative example of subject matter classified in this group:

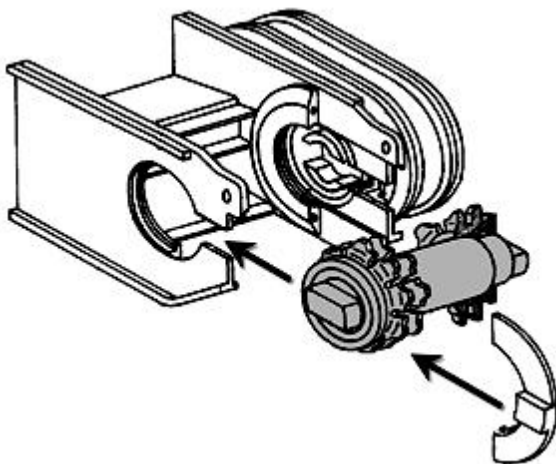

## B65G 21/12

to allow adjustment of position of load-carrier or traction element as a whole

### Definition statement

*This place covers:*

Illustrative example of subject matter classified in this group:

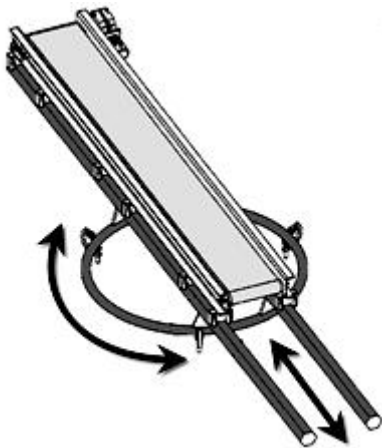

## B65G 21/14

to allow adjustment of length or configuration of load-carrier or traction element (varying speed of conveyance by adjusting configuration of load-carrier [B65G 23/00](#); {tensioning arrangements for belt or chain [B65G 23/44](#)})

### Definition statement

*This place covers:*

Illustrative example of subject matter classified in this group:

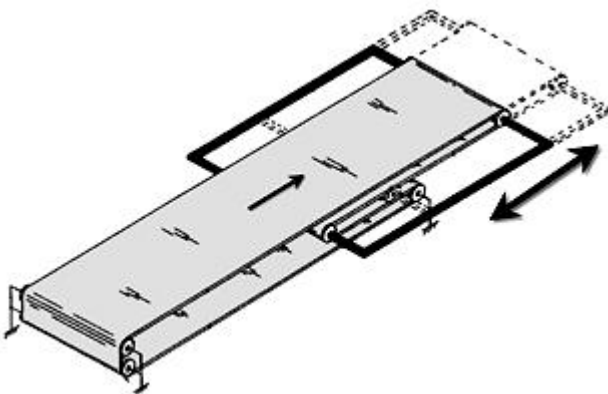



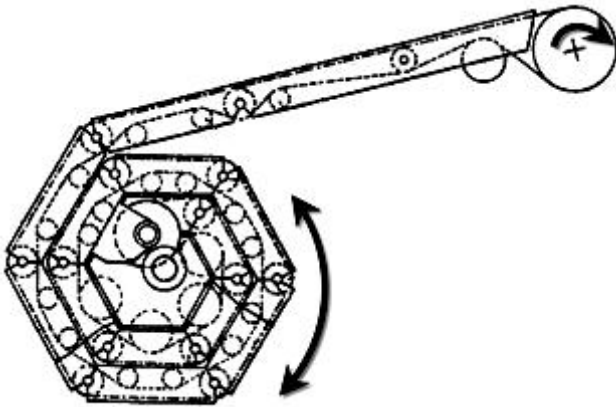

## References

### Limiting references

*This place does not cover:*

Length for configuration	<a href="#">B65G 21/20</a>
--------------------------	----------------------------

### Special rules of classification

For speed adjustment of [B65G 47/31](#) conveyors see [B65G 23/30](#).

## B65G 21/16

for conveyors having endless load-carriers movable in curved paths

### Definition statement

*This place covers:*

Illustrative example of subject matter classified in this group:

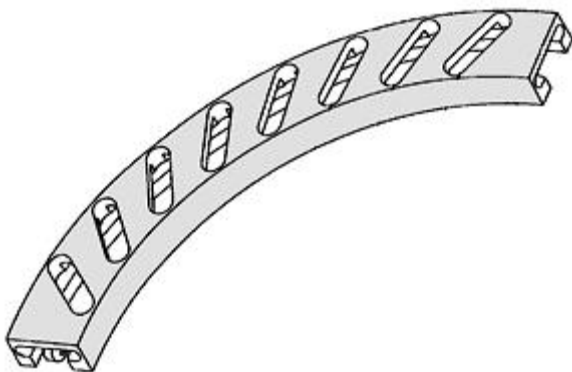

## B65G 21/18

in three-dimensionally curved paths

### Definition statement

*This place covers:*

Illustrative example of subject matter classified in this group:

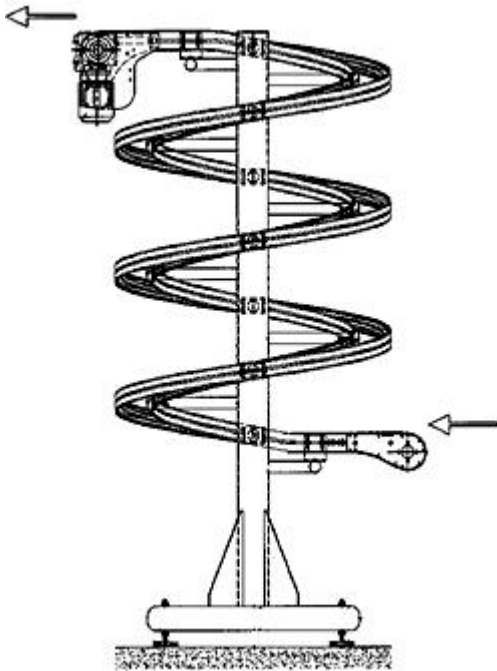

## B65G 21/20

Means incorporated in, or attached to, framework or housings for guiding load-carriers, traction elements or loads supported on moving surfaces (arrangements for supporting belts [B65G 15/60](#); rollers or roller arrangements [B65G 39/00](#))

### Definition statement

*This place covers:*

Illustrative example of subject matter classified in this group:

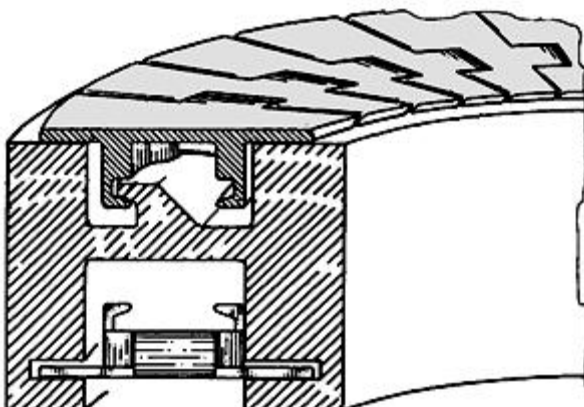

## References

### Limiting references

*This place does not cover:*

Moving rollers for supporting a chain conveyor (for belt conveyor)	<a href="#">B65G 15/60</a>
Rollers or roller arrangements	<a href="#">B65G 39/00</a>

### Informative references

*Attention is drawn to the following places, which may be of interest for search:*

Details of chain conveyors	<a href="#">B65G 17/30</a>
The supporting surface being provided with rollers	<a href="#">B65G 19/306</a>
Belts, cables or ropes predominantly used for driving purposes; Chains; Fittings predominantly used therefor	<a href="#">F16G</a>
Frames for freezing/cooling purposes	<a href="#">F25D 3/11</a> , <a href="#">F25D 13/06</a> , <a href="#">F25D 25/04</a>

## B65G 21/2009

{Magnetic retaining means}

### Definition statement

*This place covers:*

Illustrative example of subject matter classified in this group:

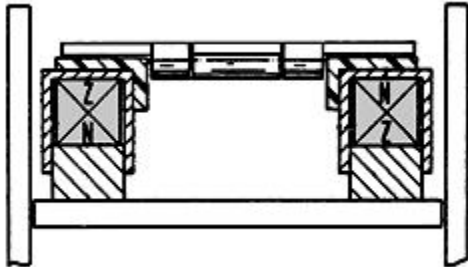

## References

### Limiting references

*This place does not cover:*

Magnetic retaining means for retaining the load on the load-carrying surface	<a href="#">B65G 21/2018</a>
------------------------------------------------------------------------------	------------------------------

## B65G 21/2018

{for retaining the load on the load-carrying surface, (retaining loads by magnetic load-carriers, e.g. belts [B65G 15/58](#), chains [B65G 17/46](#); individual magnetic grippers [B65G 17/323](#))}

### Definition statement

*This place covers:*

Illustrative example of subject matter classified in this group:

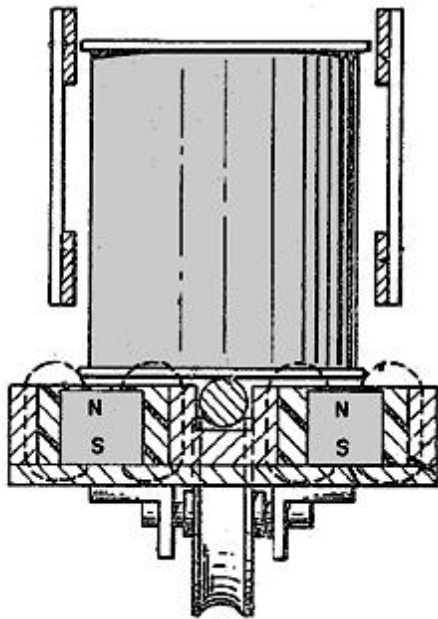

### References

#### Informative references

*Attention is drawn to the following places, which may be of interest for search:*

Stacking	<a href="#">B65G 57/04</a>
Destacking	<a href="#">B65G 59/04</a>
Stacking (FICLA)	B65G15/58&A
Chains (FICLA)	B65G15/46&B

**B65G 21/2027****{Suction retaining means}****Definition statement***This place covers:*

Illustrative example of subject matter classified in this group:

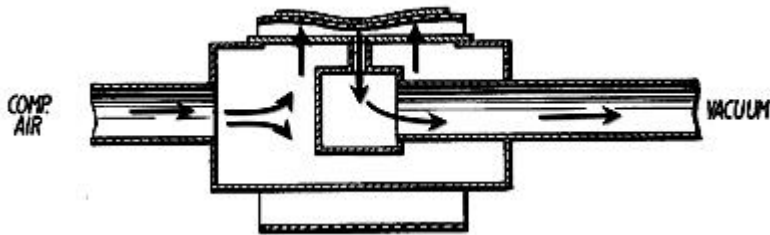
**References****Limiting references***This place does not cover:*

For retaining the load on the load-carrying surface	<a href="#">B65G 21/2036</a>
-----------------------------------------------------	------------------------------

**B65G 21/2036****{for retaining the load on the load-carrying surface (individual suction grippers [B65G 17/323](#))}****Definition statement***This place covers:*

Illustrative example of subject matter classified in this group:

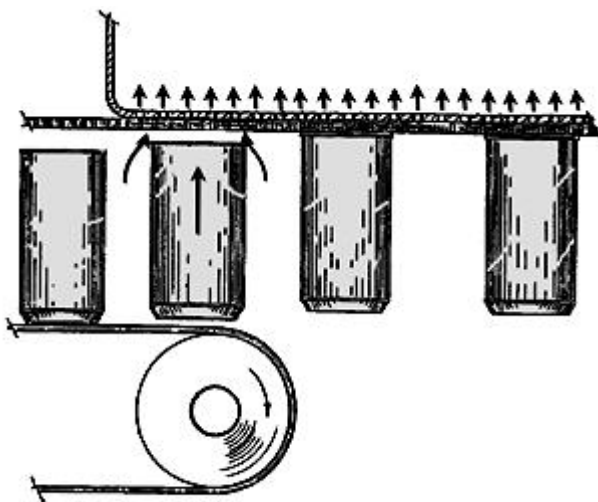

## References

### Informative references

Attention is drawn to the following places, which may be of interest for search:

Stacking	<a href="#">B65G 57/04</a>
Destacking	<a href="#">B65G 59/04</a>
Stacking (FICLA)	B65G15/58&A
Chains (FICLA)	B65G15/46&B

## B65G 21/2054

{comprising elements movable in the direction of load-transport}

### Definition statement

*This place covers:*

Illustrative example of subject matter classified in this group:

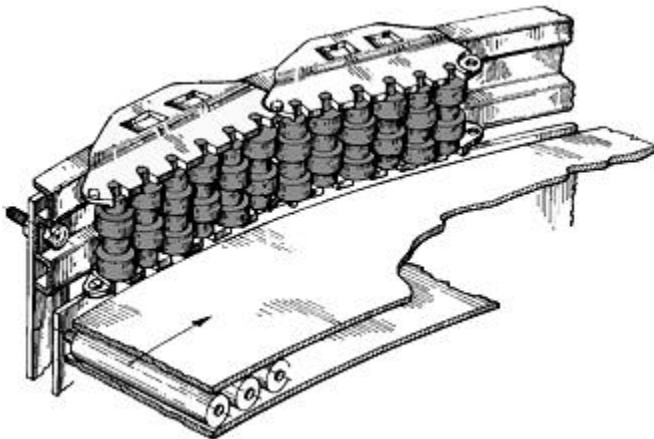

## References

### Informative references

Attention is drawn to the following places, which may be of interest for search:

See also for the construction of the roller itself	<a href="#">B65G 39/18</a>
----------------------------------------------------	----------------------------

## B65G 21/2063

{comprising elements not movable in the direction of load-transport}

### Definition statement

*This place covers:*

Illustrative example of subject matter classified in this group:

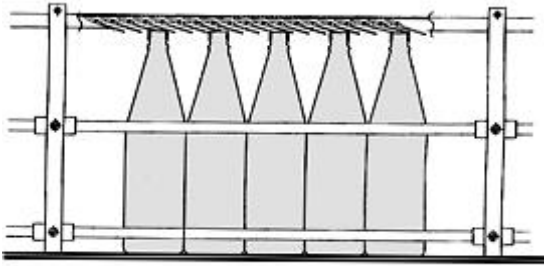

## B65G 21/2072

{Lateral guidance means}

### Definition statement

*This place covers:*

Illustrative example of subject matter classified in this group:

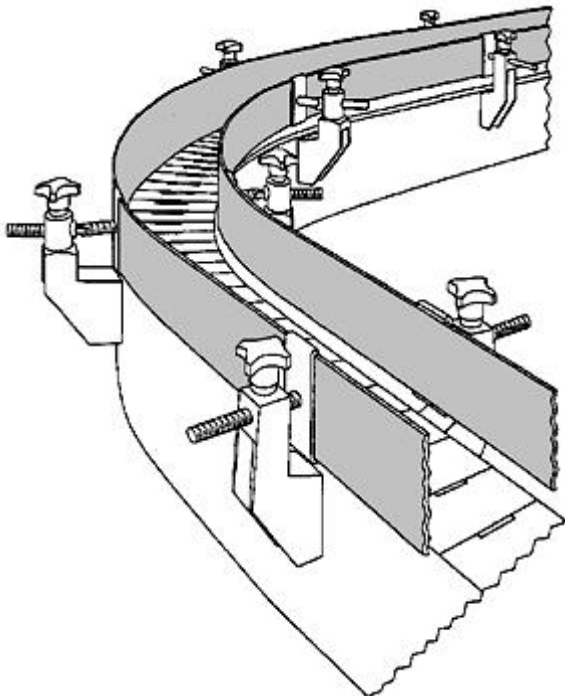

## B65G 21/2081

{for bulk material, e.g. skirts}

### Definition statement

*This place covers:*

Illustrative example of subject matter classified in this group:

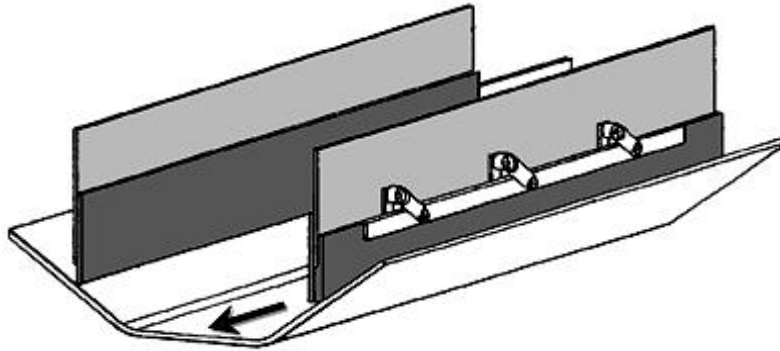

## B65G 21/209

{for augmenting or creating a pressure force between the load and the load-carrying surface}

### Definition statement

*This place covers:*

Illustrative example of subject matter classified in this group:

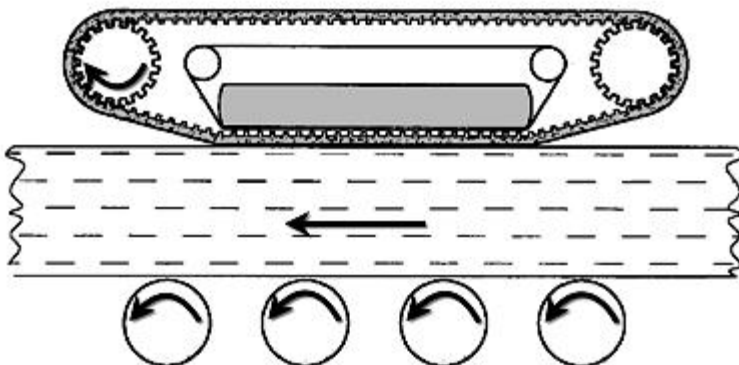



## B65G 21/22

Rails or the like engaging sliding elements or rollers attached to load-carriers or traction elements

### Definition statement

*This place covers:*

Illustrative example of subject matter classified in this group:

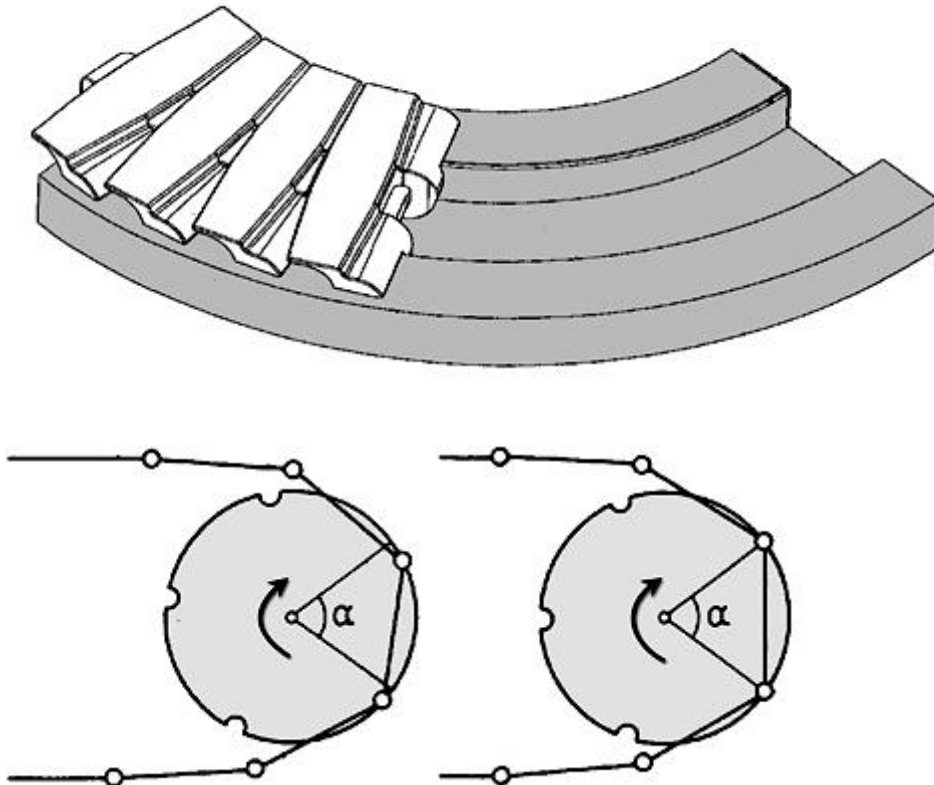

### References

#### Informative references

Attention is drawn to the following places, which may be of interest for search:

Guiding a conveyor belt in a circular arc	<a href="#">B65G 15/02</a>
Guiding means for preventing polygonal or chordal effect	<a href="#">B66B</a> , <a href="#">F16H 7/06</a>

## B65G 23/00

### Driving gear for endless conveyors; Belt- or chain-tensioning arrangements

#### Definition statement

*This place covers:*

Illustrative example of subject matter classified in this group:

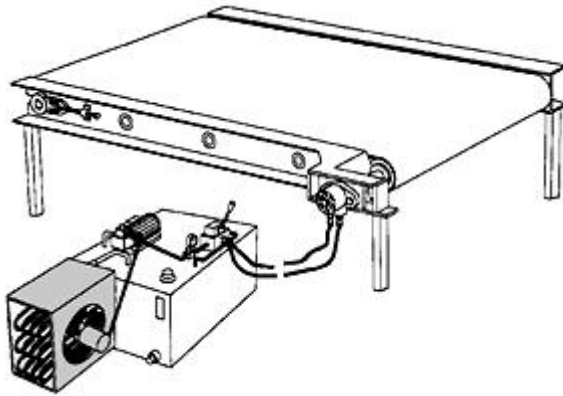
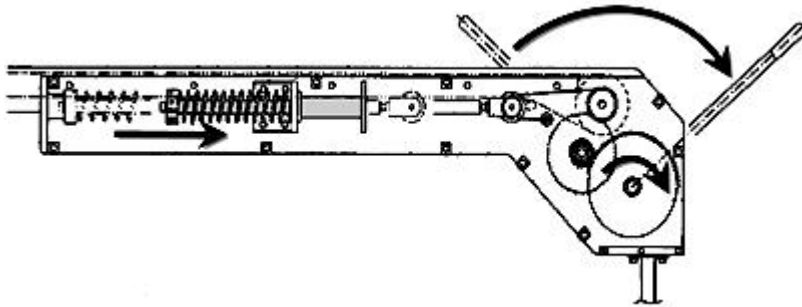

#### References

##### Informative references

*Attention is drawn to the following places, which may be of interest for search:*

If driving is specific to the spiral shape of the conveyor	<a href="#">B65G 21/18</a>
Cooling means for internal drive	<a href="#">B65G 23/08</a>
Control devices for conveyors in general	<a href="#">B65G 43/00</a>
Polygonal effect	<a href="#">B66B 23/022</a>

**B65G 23/02****Belt- or chain-engaging elements****Definition statement**

*This place covers:*

Illustrative example of subject matter classified in this group:

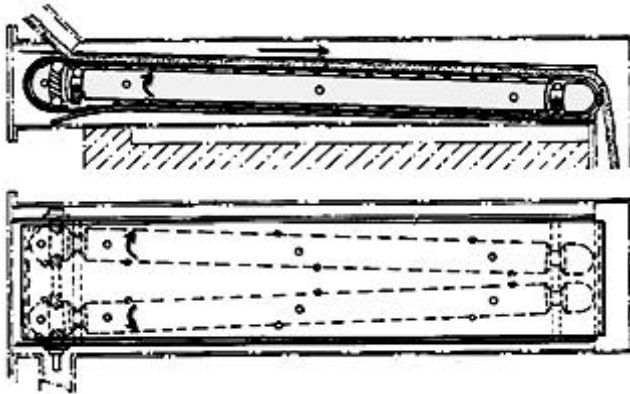
**B65G 23/04****Drums, rollers, or wheels {(B65G 23/18 takes precedence)}****Definition statement**

*This place covers:*

Illustrative example of subject matter classified in this group:

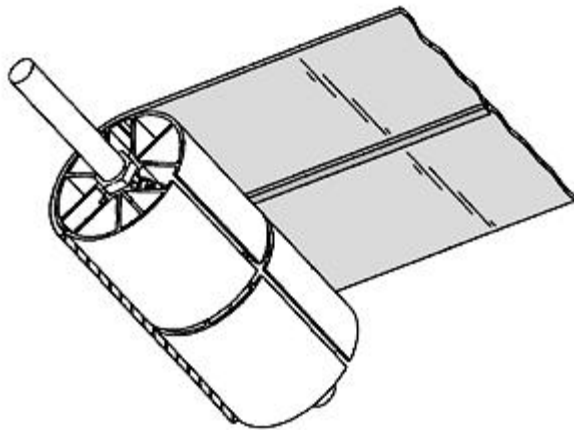
**References****Informative references**

*Attention is drawn to the following places, which may be of interest for search:*

Rollers	<a href="#">B65G 39/02</a>
---------	----------------------------

**B65G 23/06**

with projections engaging abutments on belts or chains, e.g. sprocket wheels

**Definition statement**

*This place covers:*

Illustrative example of subject matter classified in this group:

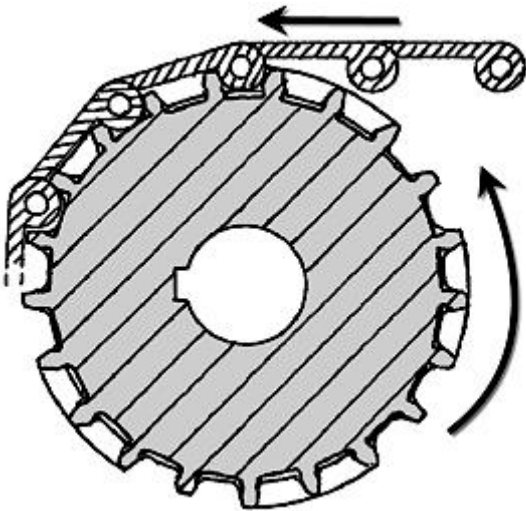
**B65G 23/08**

with self-contained driving mechanisms, e.g. motors and associated gearing

**Definition statement**

*This place covers:*

Illustrative example of subject matter classified in this group:

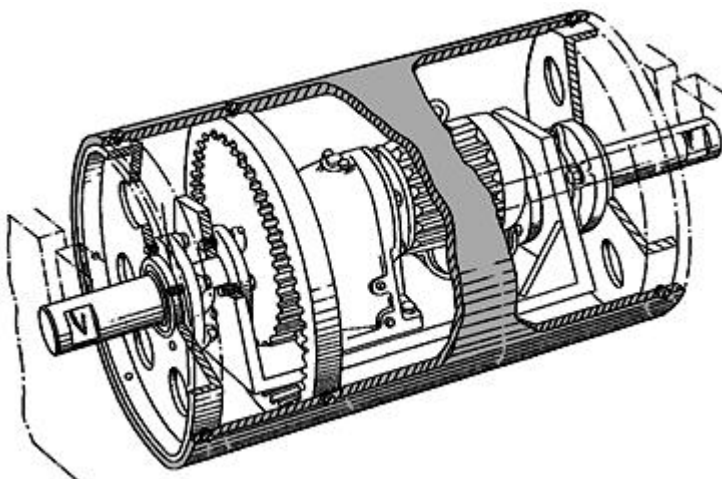
**References****Informative references**

Attention is drawn to the following places, which may be of interest for search:

Cooling means for external drive	<a href="#">B65G 23/00</a>
----------------------------------	----------------------------

Treadmills	<a href="#">A63B 22/0235</a>
------------	------------------------------

## B65G 23/10

arranged intermediate the ends of the conveyors

### Definition statement

*This place covers:*

Illustrative example of subject matter classified in this group:

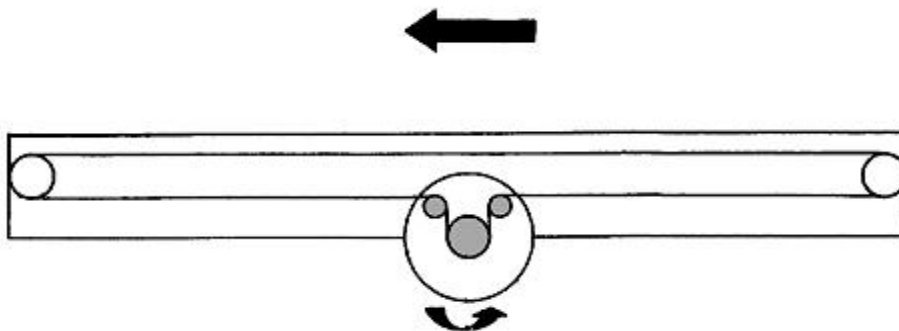

### References

#### Limiting references

*This place does not cover:*

Arrangements of co-operating drums or rollers to augment tractive effort applied to the belts	<a href="#">B65G 23/12</a>
-----------------------------------------------------------------------------------------------	----------------------------

## B65G 23/12

Arrangements of co-operating drums or rollers to augment tractive effort applied to the belts

### Definition statement

*This place covers:*

Illustrative example of subject matter classified in this group:

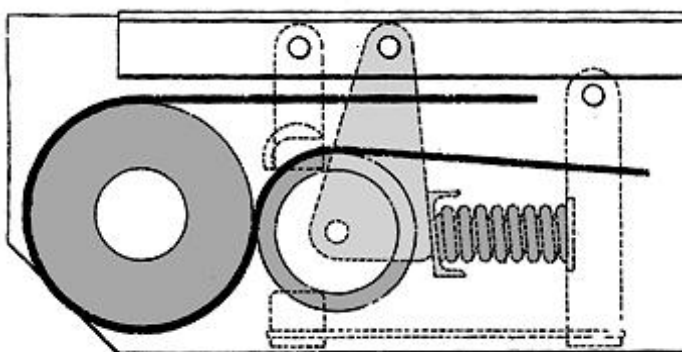

**B65G 23/14**

Endless driving elements extending parallel to belt or chain {(B65G 23/18 takes precedence)}

**Definition statement**

*This place covers:*

Illustrative example of subject matter classified in this group:

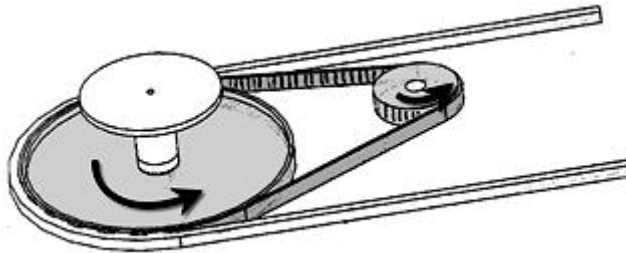
**References****Limiting references**

*This place does not cover:*

Driving gear for endless conveyors with dogs engaging abutments	<a href="#">B65G 23/18</a>
-----------------------------------------------------------------	----------------------------

**B65G 23/16**

with dogs engaging abutments on belts or chains

**Definition statement**

*This place covers:*

Illustrative example of subject matter classified in this group:

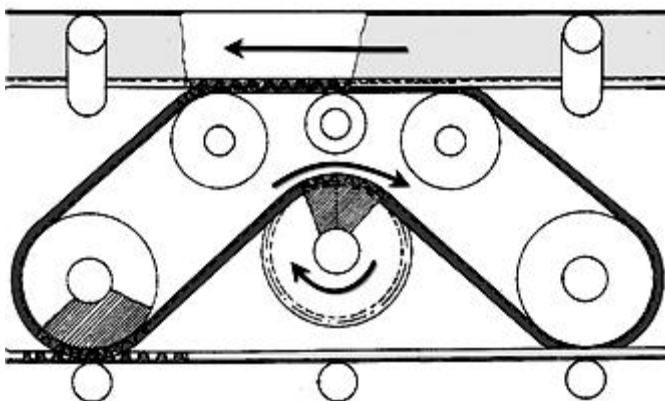

**B65G 23/18****Suction or magnetic elements****Definition statement**

*This place covers:*

Illustrative example of subject matter classified in this group:

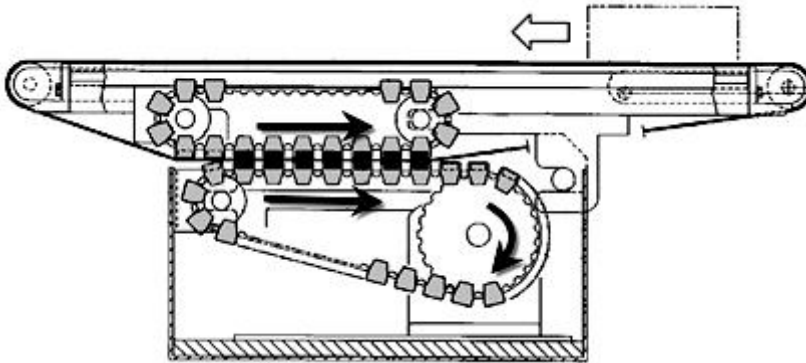
**References****Limiting references**

*This place does not cover:*

For suction elements	<a href="#">B65G 23/19</a>
----------------------	----------------------------

**B65G 23/19****Suction elements****Definition statement**

*This place covers:*

Illustrative example of subject matter classified in this group:

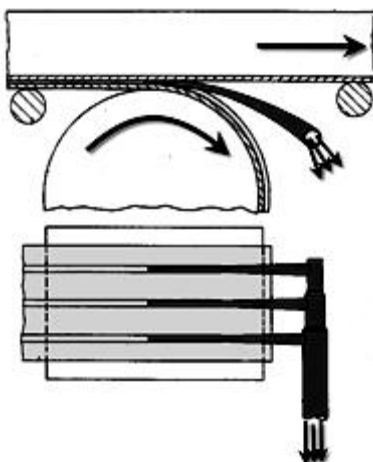



**B65G 23/20****Screws****Definition statement**

*This place covers:*

Illustrative example of subject matter classified in this group:

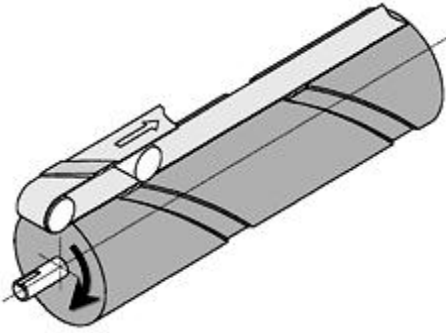
**References****Informative references**

*Attention is drawn to the following places, which may be of interest for search:*

For effecting intermittent movement	<a href="#">B65G 23/38</a>
-------------------------------------	----------------------------

**B65G 23/22**

**Arrangements or mountings of driving motors {([B65G 23/08](#) takes precedence)}**

**Definition statement**

*This place covers:*

Illustrative example of subject matter classified in this group:

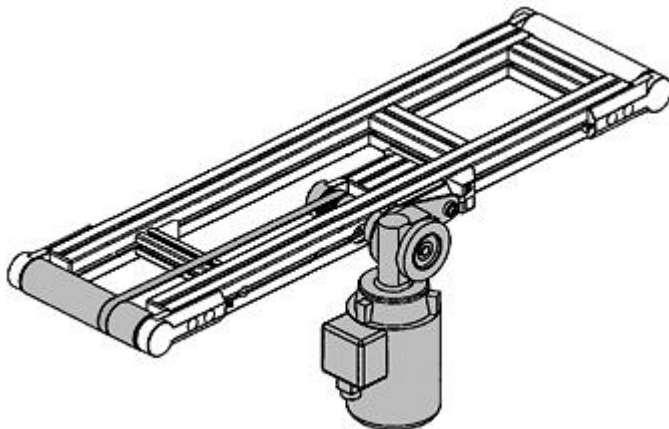



## B65G 23/23

### of electric linear motors

#### Definition statement

*This place covers:*

The belt or chain is driven as a load propelled by the reactive means of the electric linear motor.

Illustrative example of subject matter classified in this group:

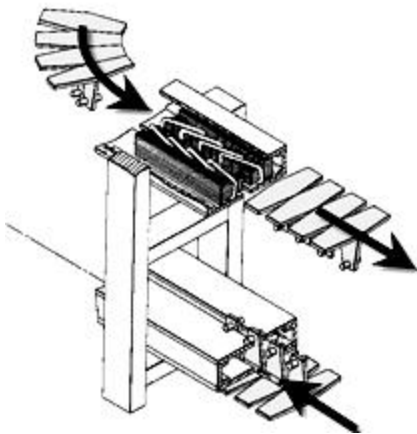

## B65G 23/24

### Gearing between driving motor and belt- or chain-engaging elements (contained in drums, rollers or wheels [B65G 23/08](#))

#### Definition statement

*This place covers:*

Illustrative example of subject matter classified in this group:

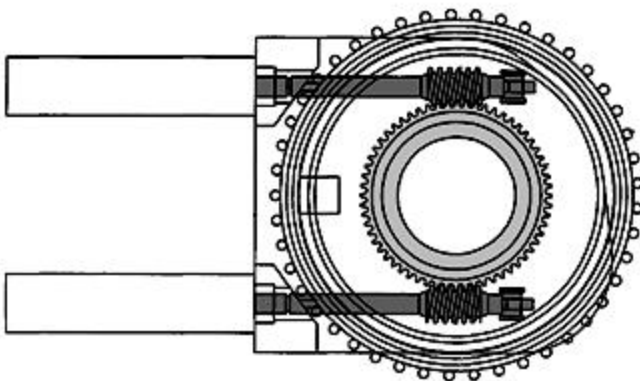

**B65G 23/26****Applications of clutches or brakes****Definition statement**

*This place covers:*

Illustrative example of subject matter classified in this group:

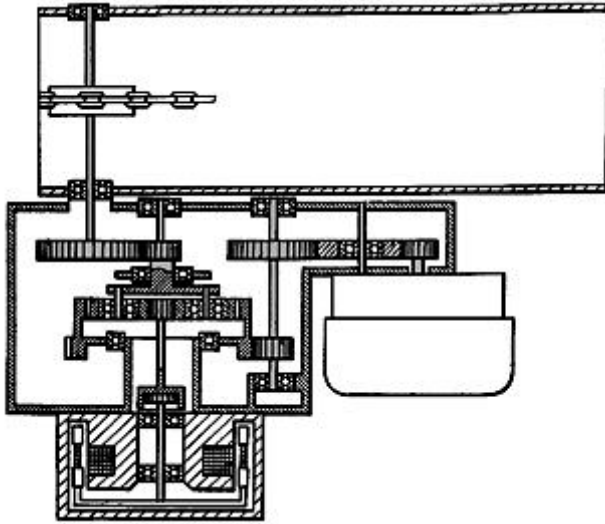
**References****Informative references**

*Attention is drawn to the following places, which may be of interest for search:*

Emergency stop	<a href="#">B65G 43/06</a>
----------------	----------------------------

**B65G 23/28****Arrangements for equalising the drive to several elements****Definition statement**

*This place covers:*

Illustrative example of subject matter classified in this group:

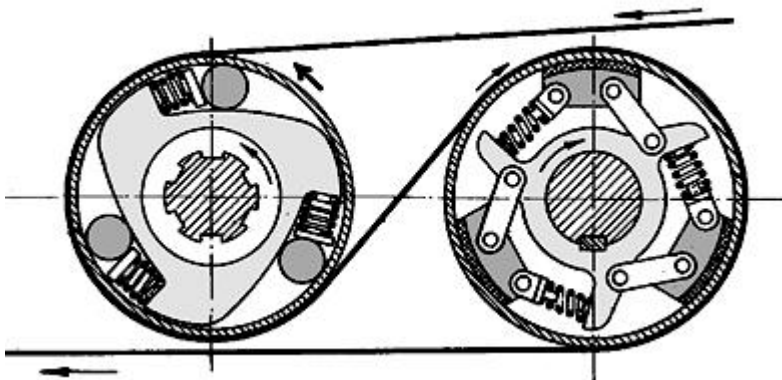

**B65G 23/30****Variable-speed gearing****Definition statement**

*This place covers:*

Illustrative example of subject matter classified in this group:

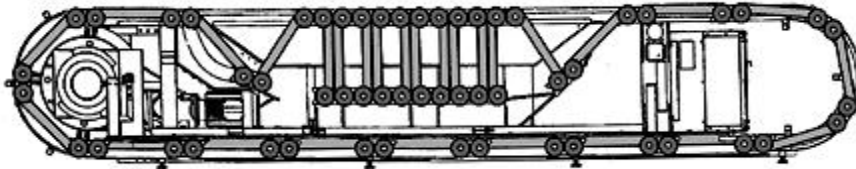
**B65G 23/32****for effecting drive at two or more points spaced along the length of the conveyors****Definition statement**

*This place covers:*

Illustrative example of subject matter classified in this group:

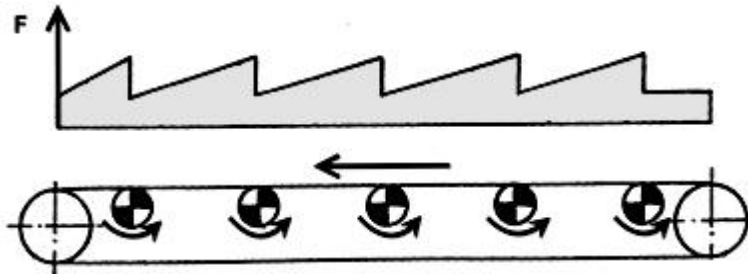
**B65G 23/34****comprising a single motor coupled to spaced driving elements****Definition statement**

*This place covers:*

Illustrative example of subject matter classified in this group:

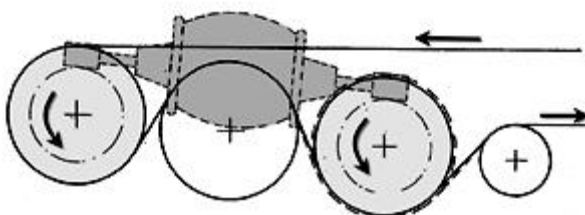

**B65G 23/36**

comprising two or more driving motors each coupled to a separate driving element, e.g. at either end of the conveyors

**Definition statement**

*This place covers:*

Illustrative example of subject matter classified in this group:

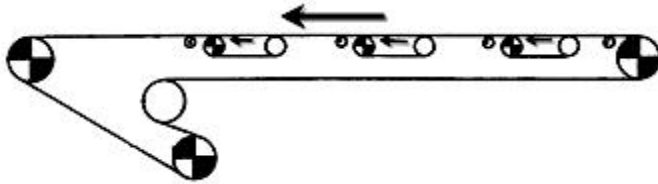
**B65G 23/38**

for effecting intermittent movement of belts or chains

**Definition statement**

*This place covers:*

Illustrative example of subject matter classified in this group:

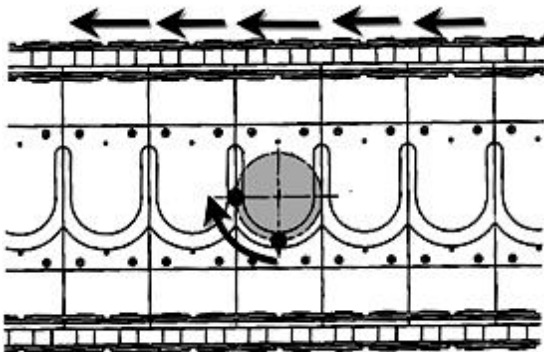
**References****Limiting references**

*This place does not cover:*

Driving screws	<a href="#">B65G 23/20</a>
----------------	----------------------------

**B65G 23/40****Applications of pawl and ratchet mechanisms or Geneva wheels****Definition statement**

*This place covers:*

Illustrative example of subject matter classified in this group:

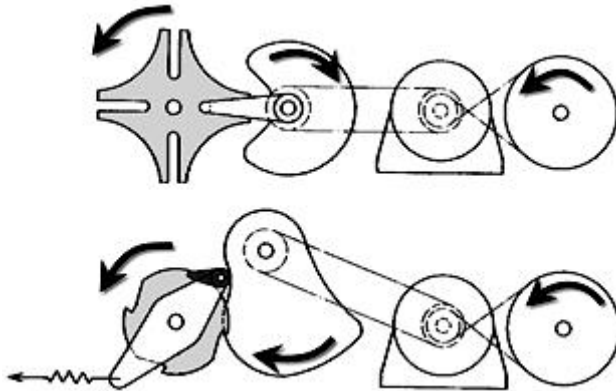
**B65G 23/42****Reciprocating members engaging successive abutments on belts or chains****Definition statement**

*This place covers:*

Illustrative example of subject matter classified in this group:

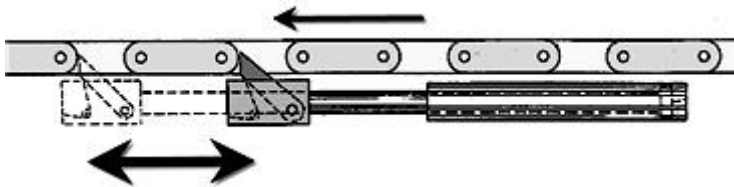
**References****Limiting references**

*This place does not cover:*

Driving wheel	<a href="#">B65G 23/38</a>
---------------	----------------------------

## B65G 23/44

### Belt or chain tensioning arrangements

#### Definition statement

*This place covers:*

Illustrative example of subject matter classified in this group:

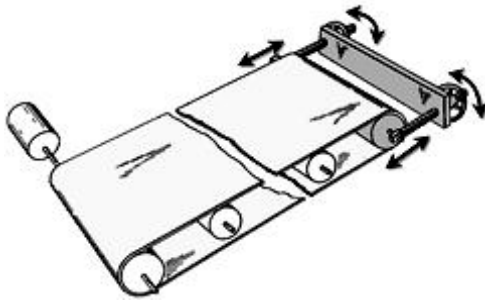

#### References

##### Informative references

*Attention is drawn to the following places, which may be of interest for search:*

Aligning belts or chains	<a href="#">B65G 39/16</a>
Saw chains	<a href="#">B27B 17/14</a>
Driving ropes, V-belts, chains	<a href="#">F16H 7/08</a>
In Xerox printers	<a href="#">G03G 15/1615</a>
Electrography	<a href="#">G03G 2215/00156</a>

## B65G 25/00

**Conveyors comprising a cyclically-moving, e.g. reciprocating, carrier or impeller which is disengaged from the load during the return part of its movement (jigging [B65G 27/00](#))**

#### References

##### Limiting references

*This place does not cover:*

Jigging conveyors	<a href="#">B65G 27/00</a>
-------------------	----------------------------

##### Informative references

*Attention is drawn to the following places, which may be of interest for search:*

Feeding or discharging conveyors by devices incorporated in, or operatively associated with, conveyors	<a href="#">B65G 47/00</a>
Loading or unloading	<a href="#">B65G 65/00</a>
Walking beam conveyors	<a href="#">B65G 2812/09</a>
Conveyors with reciprocating means	<a href="#">B65G 2812/12</a>

### Special rules of classification

This group is dedicated to conveyors with substantial paths of movement in contrast to [B65G 27/00](#) (jigging conveyors).

### B65G 25/02

**the carrier or impeller having different forward and return paths of movement, e.g. walking beam conveyors**

#### Definition statement

*This place covers:*

Illustrative example of subject matter classified in this group:

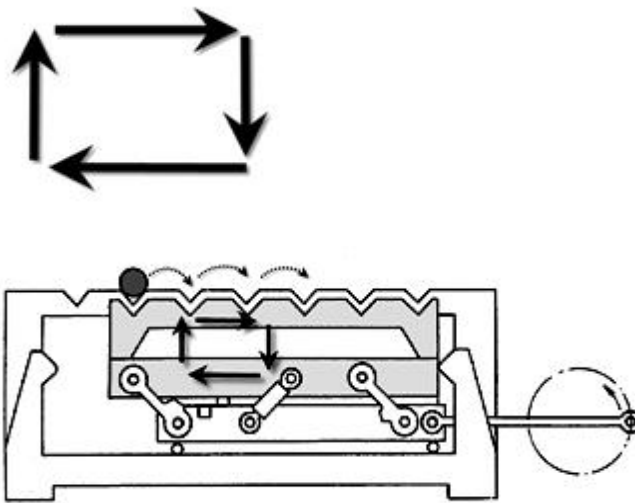

### References

#### Informative references

Attention is drawn to the following places, which may be of interest for search:

Vertical transfer	<a href="#">B65G 35/00</a>
Old technology	<a href="#">B65G 2812/12</a>
Removing chips in a machine tool	<a href="#">B23Q 11/0057</a>

### B65G 25/04

**the carrier or impeller having identical forward and return paths of movement, e.g. reciprocating conveyors**

#### Definition statement

*This place covers:*

Illustrative example of subject matter classified in this group:



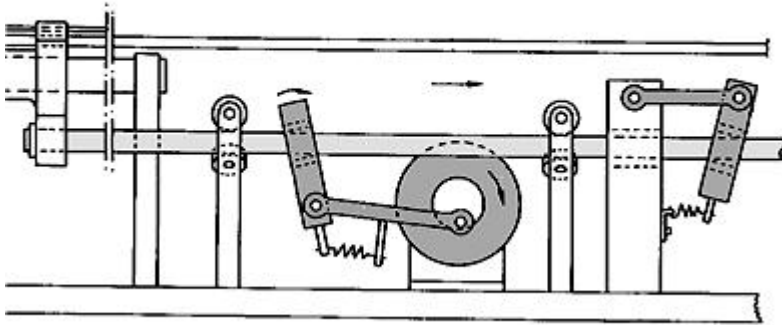

## References

### Informative references

Attention is drawn to the following places, which may be of interest for search:

Old technology	<a href="#">B65G 2812/09</a>
----------------	------------------------------

## B65G 25/06

having carriers, e.g. belts

### Definition statement

This place covers:

Illustrative example of subject matter classified in this group:

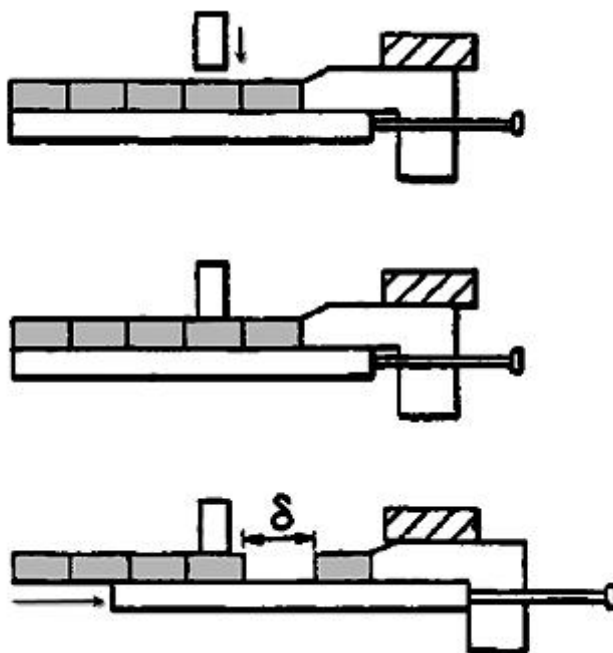



## B65G 25/065

{Reciprocating floor conveyors}

### Definition statement

*This place covers:*

Illustrative example of subject matter classified in this group:

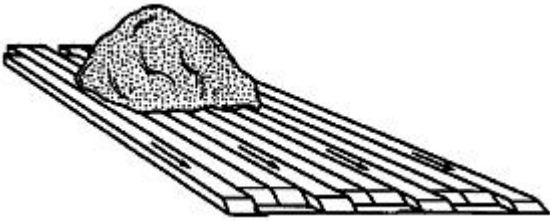
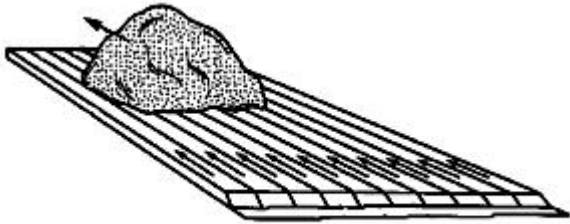

## B65G 25/08

having impellers, e.g. pushers

### Definition statement

*This place covers:*

Illustrative example of subject matter classified in this group:

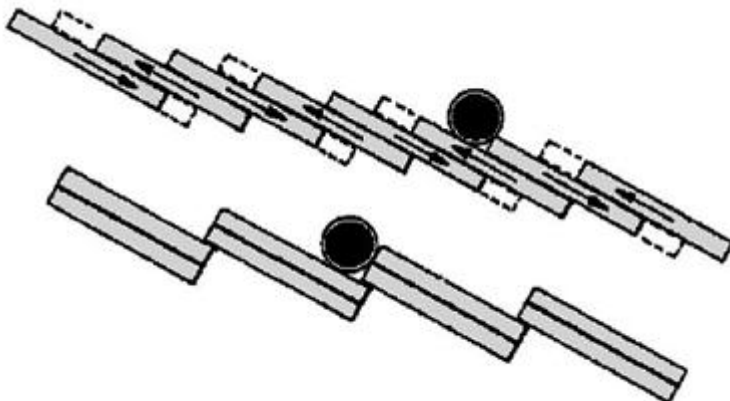

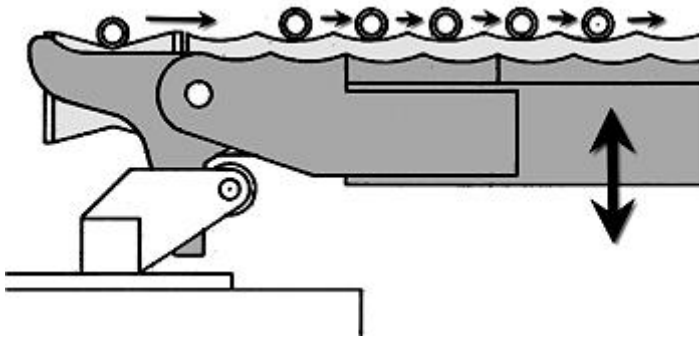

## References

### Informative references

Attention is drawn to the following places, which may be of interest for search:

Devices for feeding articles or materials to conveyors (Movement in one direction, substantially outwards)	<a href="#">B65G 47/1471</a>
By means of pick-up devices, the container remaining immobile	<a href="#">B65G 47/1478</a>
Vertically reciprocating carriers with inclined surfaces to roll articles to the next stop	<a href="#">B65G 47/266</a>

## B65G 25/10

with impeller pivotally mounted on a reciprocating bar

### Definition statement

This place covers:

Illustrative example of subject matter classified in this group:

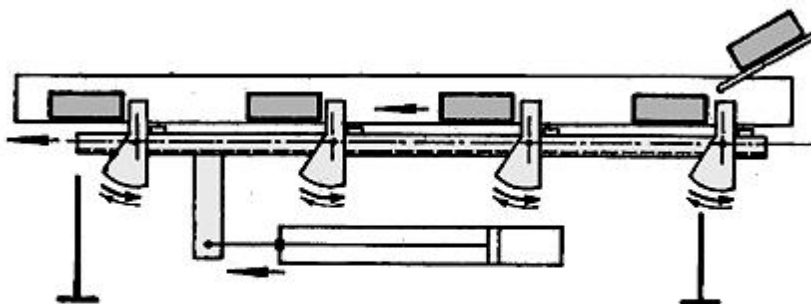

## B65G 25/12

with impeller fixed to a reciprocating bar and the bar being rotated about its longitudinal axis on its return stroke

### Definition statement

*This place covers:*

Illustrative example of subject matter classified in this group:

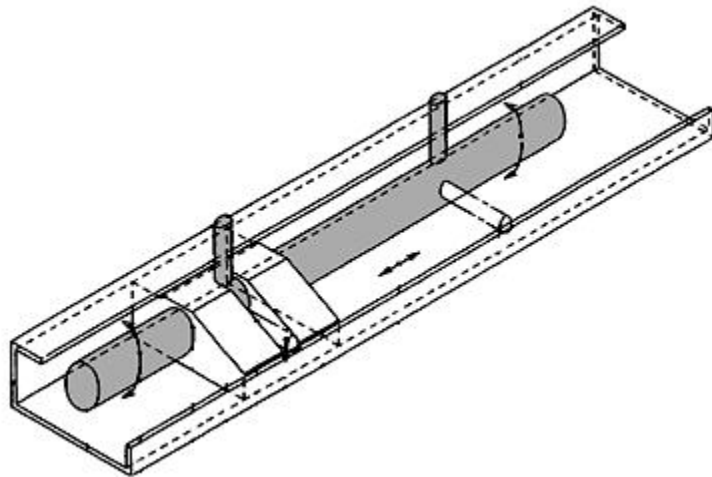

## B65G 27/00

Jigging conveyors

### Definition statement

*This place covers:*

Illustrative example of subject matter classified in this group:

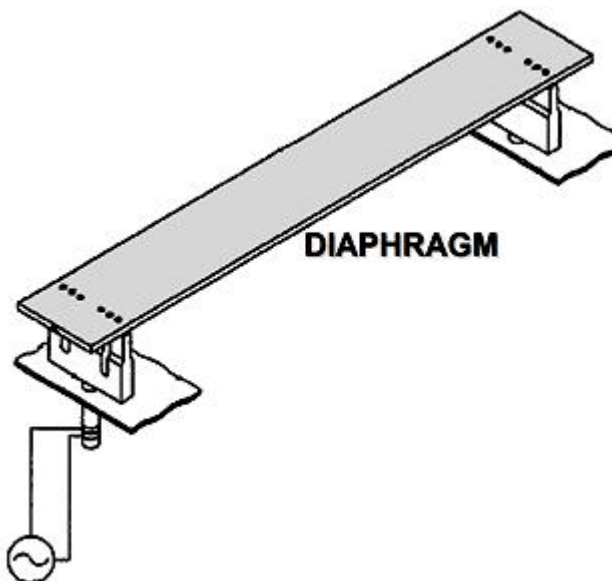

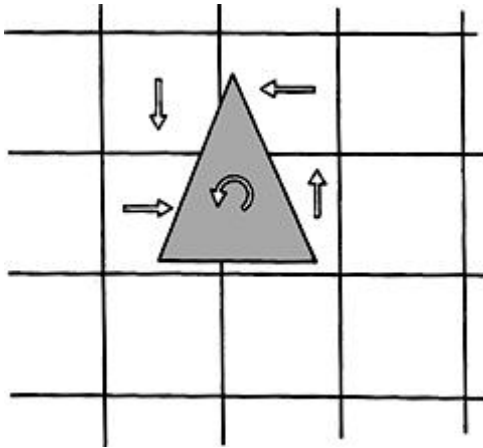

## References

### Application-oriented references

Examples of places where the subject matter of this place is covered when specially adapted, used for a particular purpose, or incorporated in a larger system:

Jigs for wet separation	<a href="#">B03B</a>
Jiggers for screening, sifting or sorting	<a href="#">B07B 1/28</a>

### Informative references

Attention is drawn to the following places, which may be of interest for search:

Feeding or discharging conveyors by devices incorporated in, or operatively associated with, conveyors	<a href="#">B65G 47/00</a>
Loading or unloading	<a href="#">B65G 65/00</a>
Vibrating conveyors	<a href="#">B65G 2812/03</a> - <a href="#">B65G 2812/0396</a>
Generating or transmitting mechanical vibrations	<a href="#">B06</a>

**B65G 27/02**

comprising helical or spiral channels or conduits for elevation of materials

**Definition statement**

*This place covers:*

Illustrative example of subject matter classified in this group:

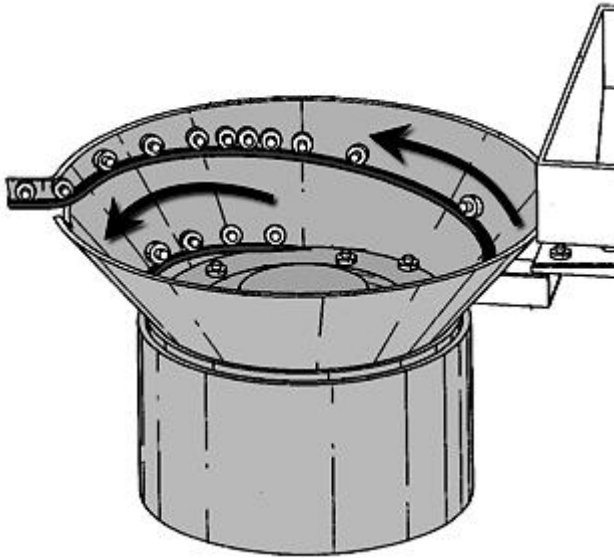
**References****Informative references**

*Attention is drawn to the following places, which may be of interest for search:*

Helical or spiral chutes in general	<a href="#">B65G 11/06</a>
Use of such conveyors for arranging or orientating articles during feeding	<a href="#">B65G 47/1421</a>

## B65G 27/04

### Load carriers other than helical or spiral channels or conduits

#### Definition statement

*This place covers:*

Illustrative example of subject matter classified in this group:

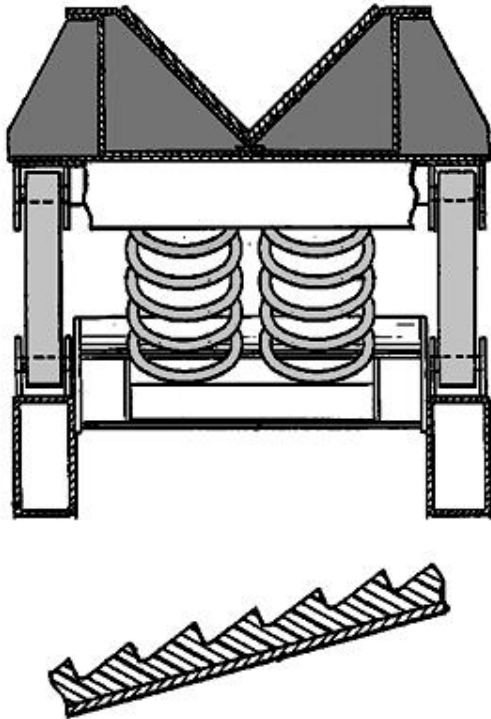

## B65G 27/06

### Joints connecting load-carrier sections

#### Definition statement

*This place covers:*

Illustrative example of subject matter classified in this group:

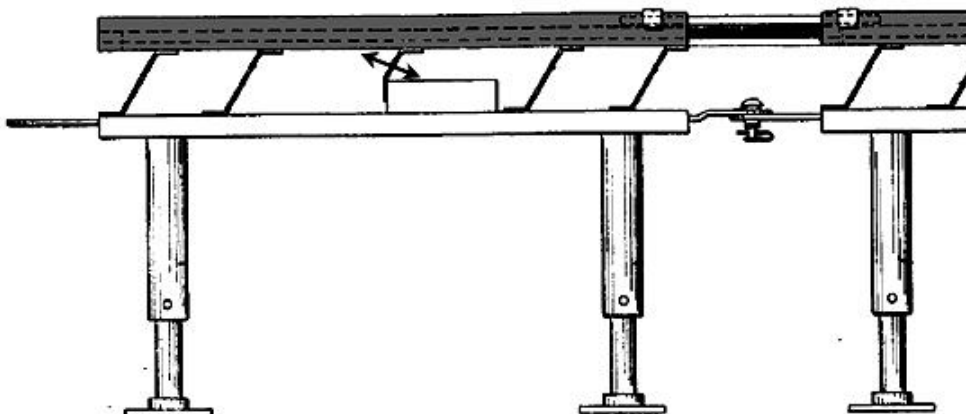

## B65G 27/08

Supports or mountings for load-carriers, e.g. framework, bases, spring arrangements ((spring arrangements as jiggling movement transmitting units [B65G 27/10](#)))

### Definition statement

*This place covers:*

Illustrative example of subject matter classified in this group:

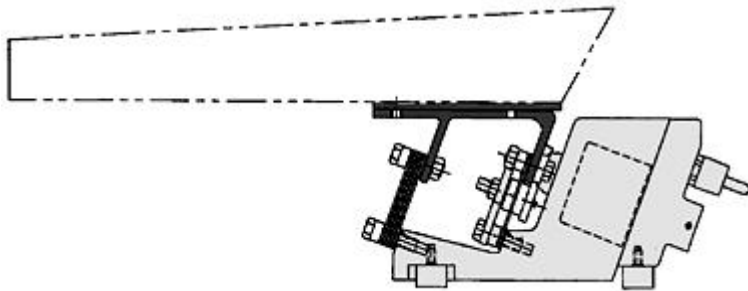

## B65G 27/12

of shaking devices, i.e. devices for producing movements of low frequency and large amplitude

### Definition statement

*This place covers:*

Illustrative example of subject matter classified in this group:

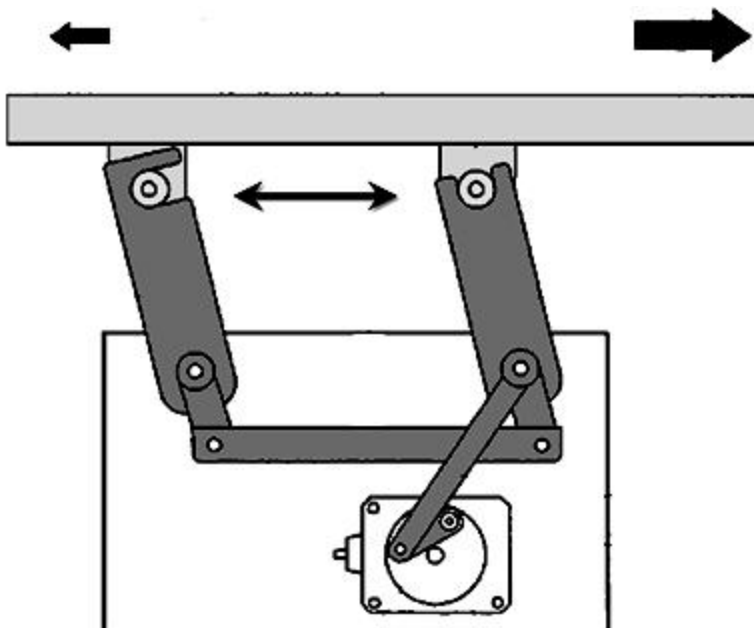

**B65G 27/14****hydraulic****Definition statement***This place covers:*

Illustrative example of subject matter classified in this group:

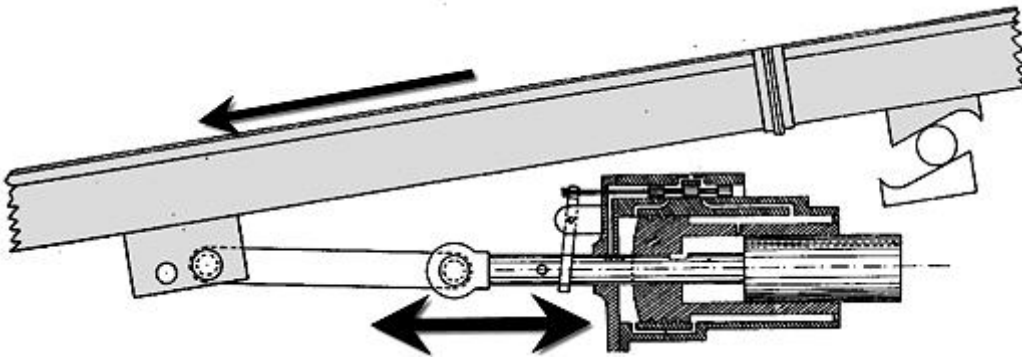
**B65G 27/16****of vibrators, i.e. devices for producing movements of high frequency and small amplitude****Definition statement***This place covers:*

Illustrative example of subject matter classified in this group.

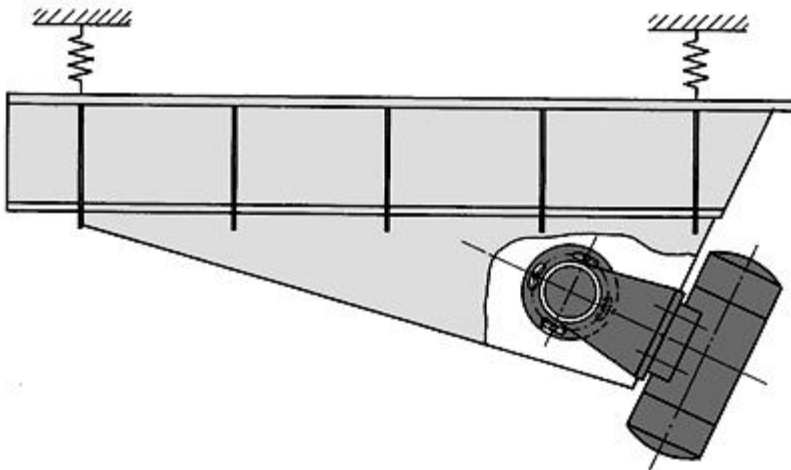



**B65G 27/18****Mechanical devices {(B65G 27/26 takes precedence)}****Definition statement***This place covers:*

Illustrative example of subject matter classified in this group:

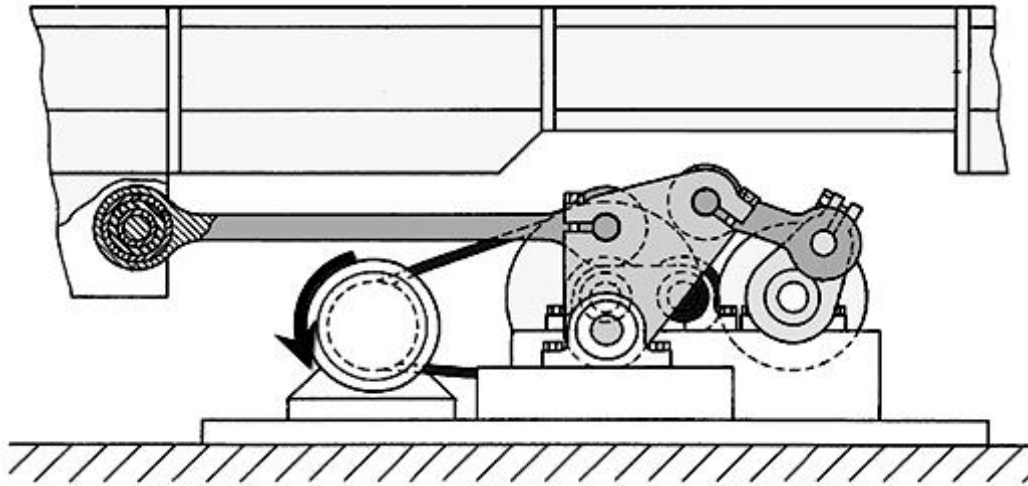
**B65G 27/20****rotating unbalanced masses****Definition statement***This place covers:*

Illustrative example of subject matter classified in this group:

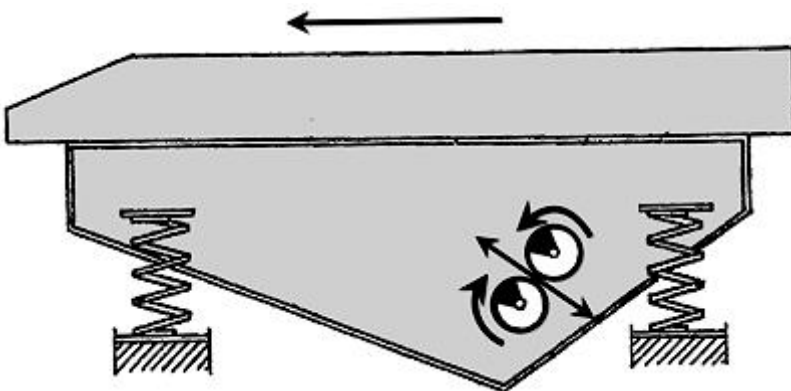

## B65G 27/22

### Hydraulic or pneumatic devices

#### Definition statement

*This place covers:*

Illustrative example of subject matter classified in this group:

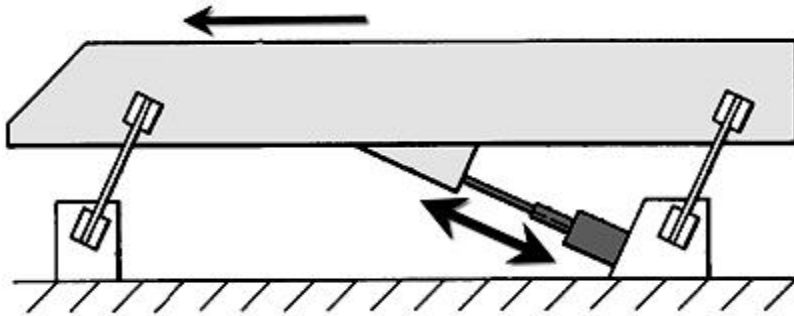

## B65G 27/24

### Electromagnetic devices

#### Definition statement

*This place covers:*

Illustrative example of subject matter classified in this group:

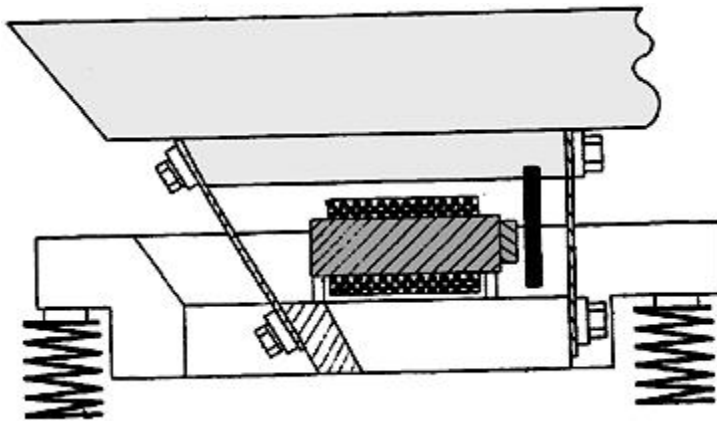

## B65G 27/26

with elastic coupling between vibrator and load carrier

### Definition statement

*This place covers:*

Illustrative example of subject matter classified in this group:

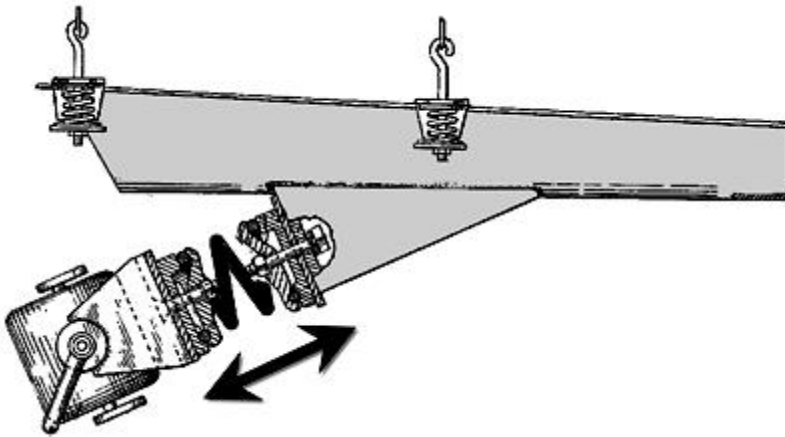

## B65G 27/28

with provision for dynamic balancing

### Definition statement

*This place covers:*

Illustrative example of subject matter classified in this group:

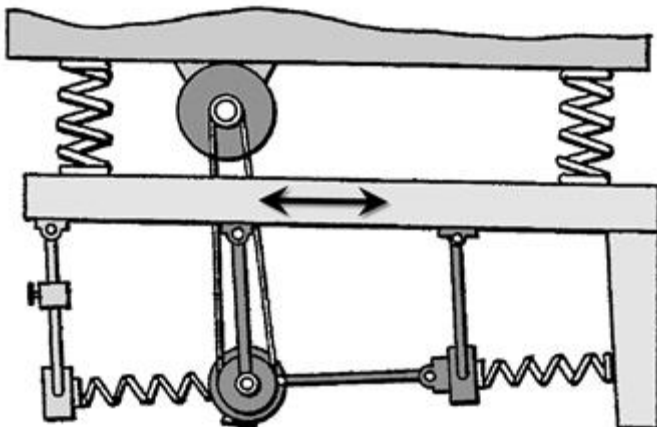

**B65G 27/30**

by means of an oppositely-moving mass, e.g. a second conveyor

**Definition statement**

*This place covers:*

Illustrative example of subject matter classified in this group:

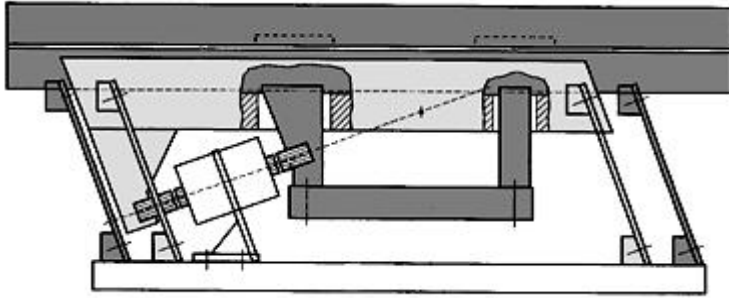
**B65G 27/32**

with means for controlling direction, frequency or amplitude of vibration or shaking movement

**Definition statement**

*This place covers:*

Illustrative example of subject matter classified in this group:

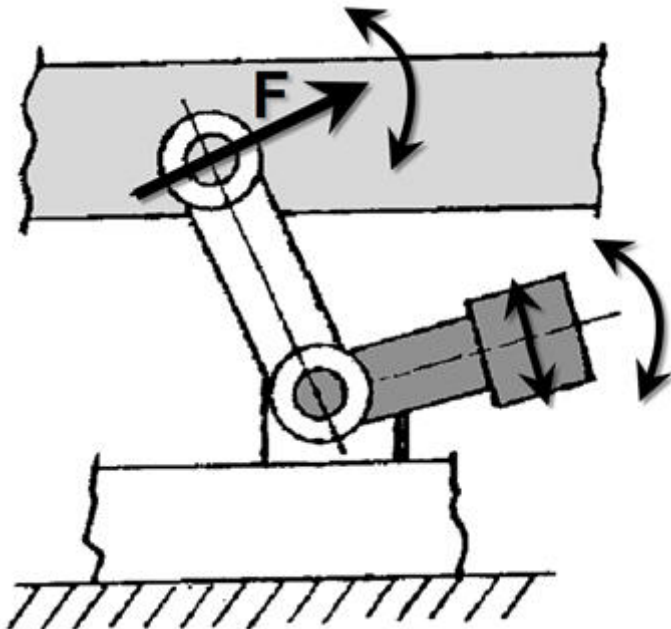

## B65G 27/34

comprising a series of co-operating units

### Definition statement

*This place covers:*

Illustrative example of subject matter classified in this group:

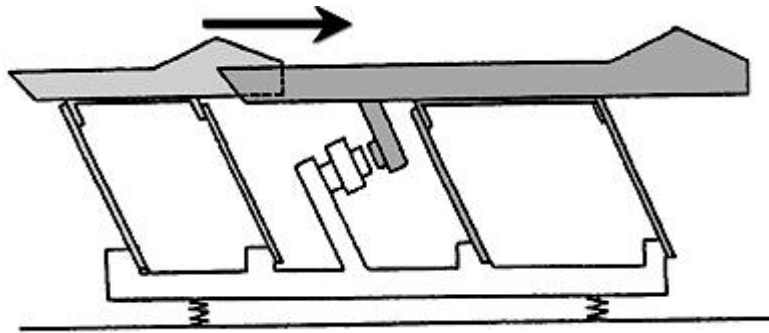

## B65G 29/00

Rotary conveyors, e.g. rotating discs, arms, star-wheels or cones (mechanical projectors [B65G 31/00](#); screw or rotary spiral conveyors [B65G 33/00](#))

### Definition statement

*This place covers:*

Illustrative example of subject matter classified in this group:

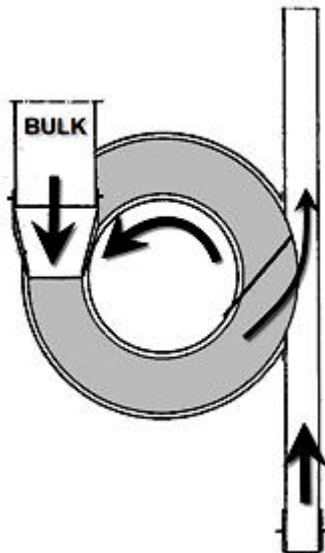

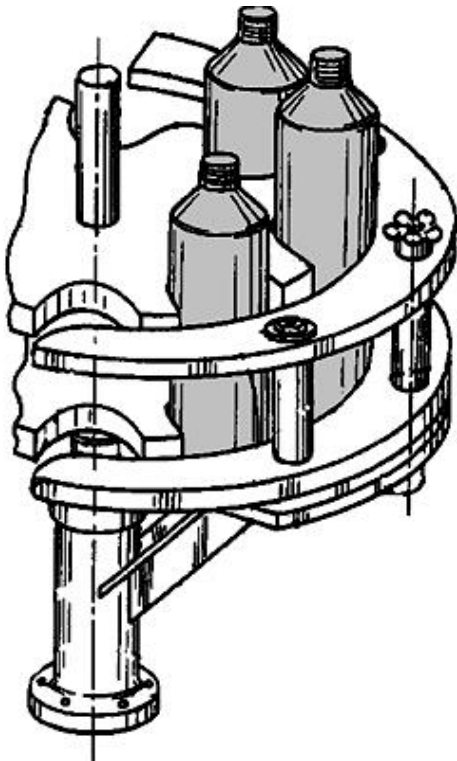
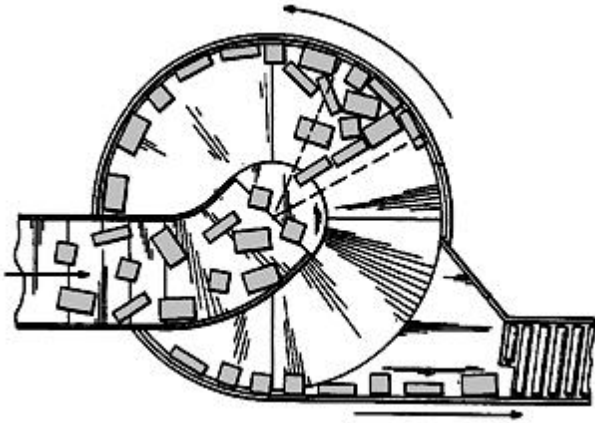

**References**

**Limiting references**

*This place does not cover:*

Mechanical projectors	<a href="#">B65G 31/00</a>
Screw or rotary spiral conveyors	<a href="#">B65G 33/00</a>

**Informative references**

*Attention is drawn to the following places, which may be of interest for search:*

Feeding or discharging conveyors by devices incorporated in, or operatively associated with, conveyors	<a href="#">B65G 47/00</a>
Turntables as feeding, transfer or discharging devices	<a href="#">B65G 47/80</a>
Starwheels as feeding, transfer or discharging devices	<a href="#">B65G 47/84</a>
For articles	<a href="#">B65G 47/846</a>

Loading or unloading	<a href="#">B65G 65/00</a>
Turntable	<a href="#">B65G 2812/14</a>

## B65G 29/02

for inclined or vertical transit

### Definition statement

*This place covers:*

Illustrative example of subject matter classified in this group:

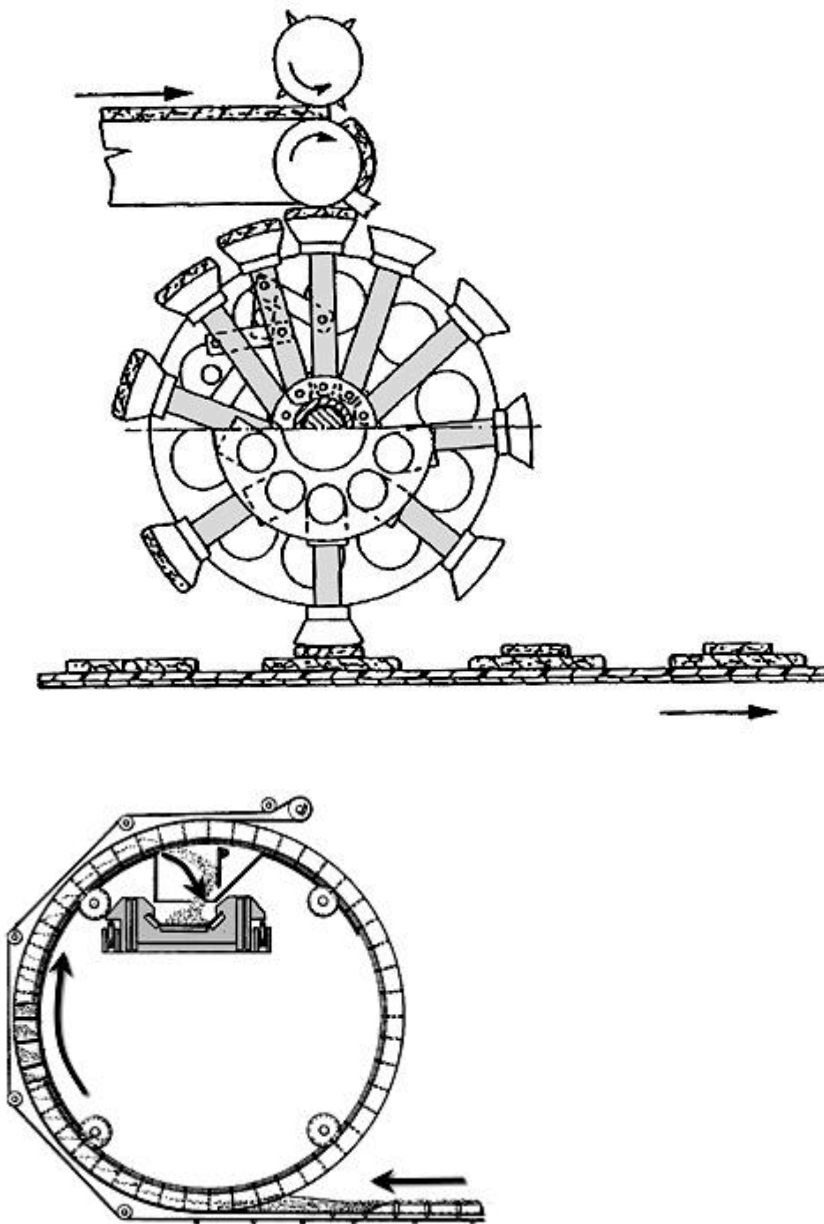

## References

### *Informative references*

Attention is drawn to the following places, which may be of interest for search:

Series of wheels	<a href="#">B65G 35/00</a>
For articles	<a href="#">B65G 47/846</a>

## B65G 31/00

### Mechanical throwing machines for articles or solid materials

## References

### *Application-oriented references*

Examples of places where the subject matter of this place is covered when specially adapted, used for a particular purpose, or incorporated in a larger system:

Distributors for fertilisers	<a href="#">A01C</a>
Moulding machines	<a href="#">B22C</a>
Sandblasting devices	<a href="#">B24C</a>
Implements for applying plaster	<a href="#">E04F 21/06</a>

### *Informative references*

Attention is drawn to the following places, which may be of interest for search:

Feeding or discharging conveyors by devices incorporated in, or operatively associated with, conveyors	<a href="#">B65G 47/00</a>
Loading or unloading	<a href="#">B65G 65/00</a>



## B65G 31/02

comprising belts

### Definition statement

*This place covers:*

Illustrative example of subject matter classified in this group

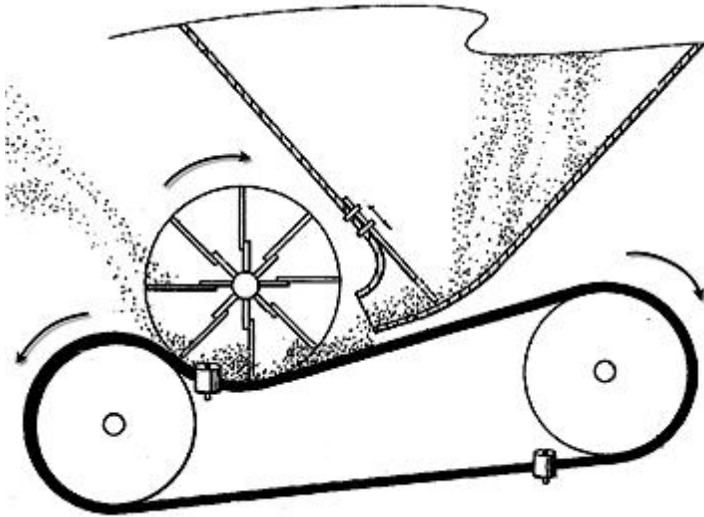

## B65G 31/04

comprising discs, drums, or like rotary impellers

### Definition statement

*This place covers:*

Illustrative example of subject matter classified in this group:

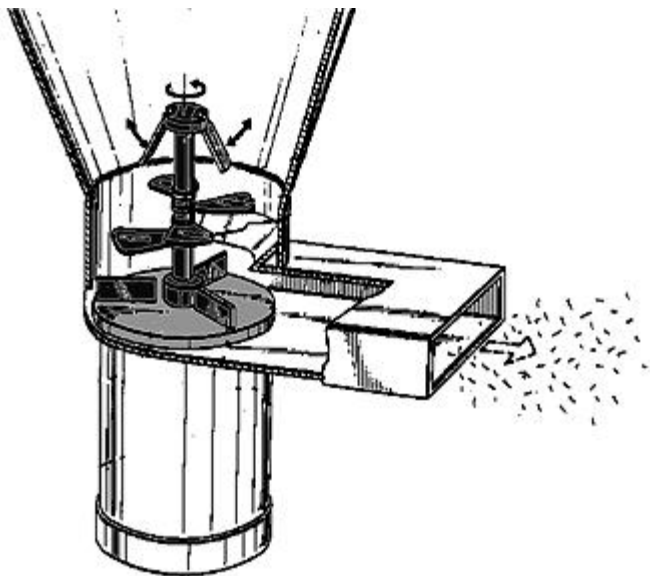

**B65G 33/00****Screw or rotary spiral conveyors****References****Informative references**

Attention is drawn to the following places, which may be of interest for search:

Feeding or discharging conveyors by devices incorporated in, or operatively associated with, conveyors	<a href="#">B65G 47/00</a>
Loading or unloading	<a href="#">B65G 65/00</a>
Screws for extruding, compressing, kneading, mixing, pumping, or other special operations	<a href="#">B01F 27/00</a> , <a href="#">B29C 48/395</a> , <a href="#">F04D</a>
Making helical bodies	<a href="#">B21H 3/00</a>
Dewatering	<a href="#">B30B 9/12</a>
Screw-press for dewatering solid material	<a href="#">B30B 11/00</a> , <a href="#">C02F 11/00</a>

**B65G 33/02****for articles****Definition statement**

*This place covers:*

Illustrative example of subject matter classified in this group:

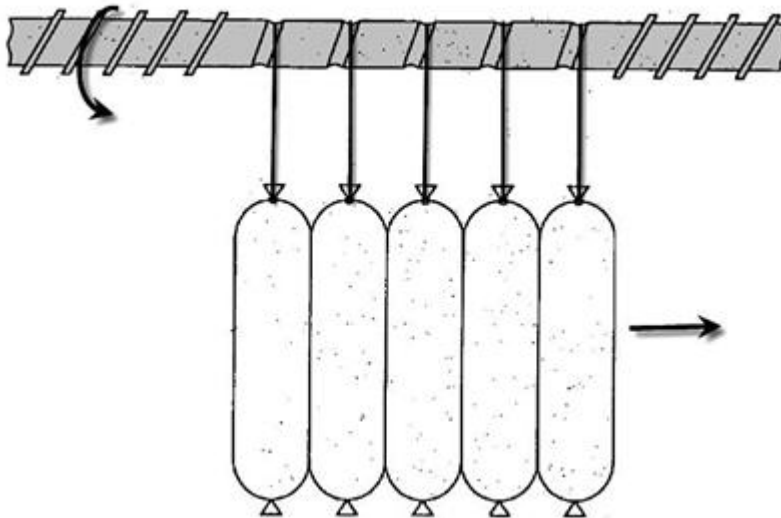

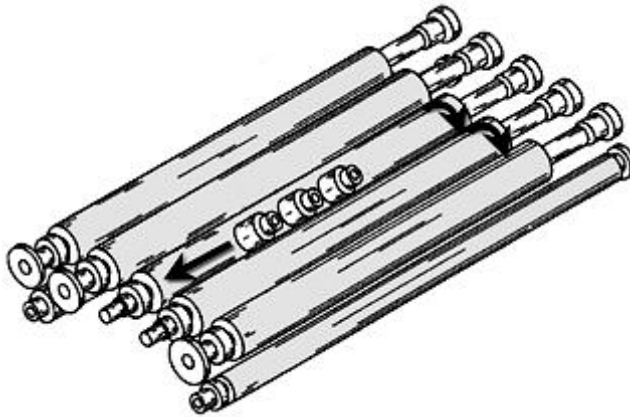

## References

### Informative references

Attention is drawn to the following places, which may be of interest for search:

Carriers	<a href="#">B65G 35/063</a>
----------	-----------------------------

## B65G 33/04

conveyed between a single screw and guiding means

### Definition statement

This place covers:

Illustrative example of subject matter classified in this group:

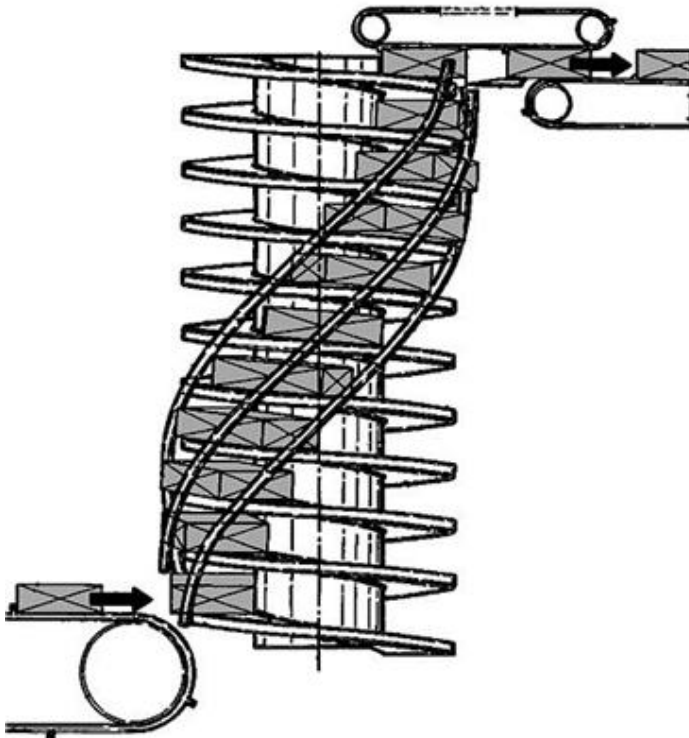

## B65G 33/06

conveyed and guided by parallel screws

### Definition statement

*This place covers:*

Illustrative example of subject matter classified in this group:

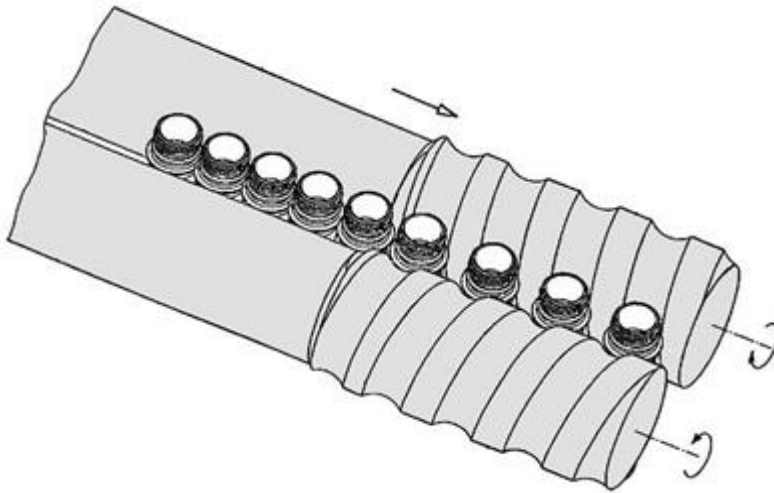

## B65G 33/10

with non-enclosed screws

### Definition statement

*This place covers:*

Illustrative example of subject matter classified in this group:

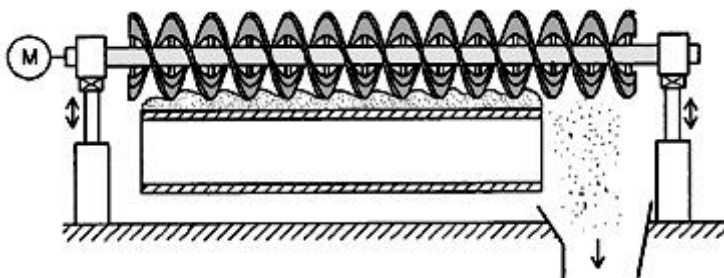

## B65G 33/12

with screws formed by straight tubes or drums having internal threads, or by spiral or helical tubes

### Definition statement

*This place covers:*

Illustrative example of subject matter classified in this group:

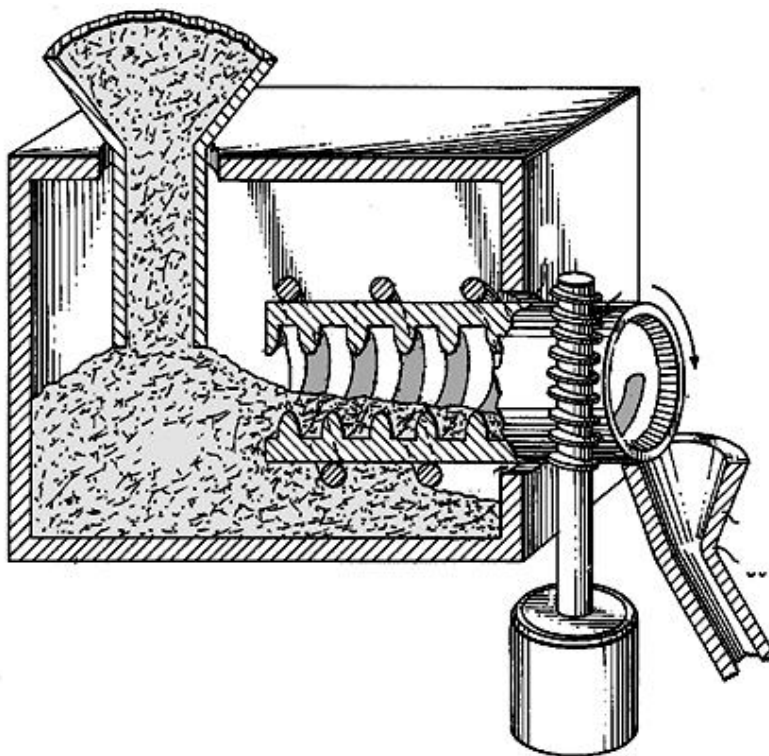
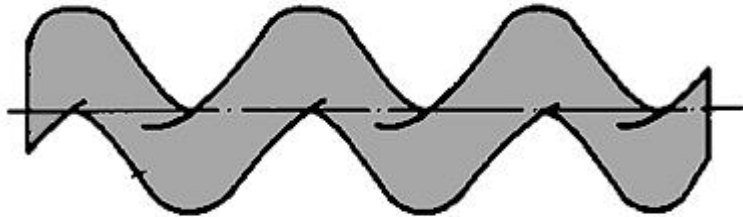

### References

#### *Informative references*

*Attention is drawn to the following places, which may be of interest for search:*

Rotating tubes for unloading hoppers	<a href="#">B65G 65/489</a>
--------------------------------------	-----------------------------

## **B65G 33/14**

**comprising a screw or screws enclosed in a tubular housing**

### **Definition statement**

*This place covers:*

Illustrative example of subject matter classified in this group:

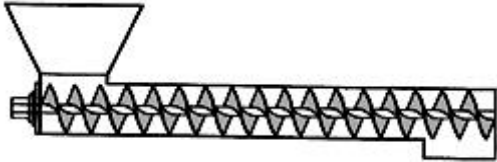

## **B65G 33/16**

**with flexible screws operating in flexible tubes**

### **Definition statement**

*This place covers:*

Illustrative example of subject matter classified in this group:

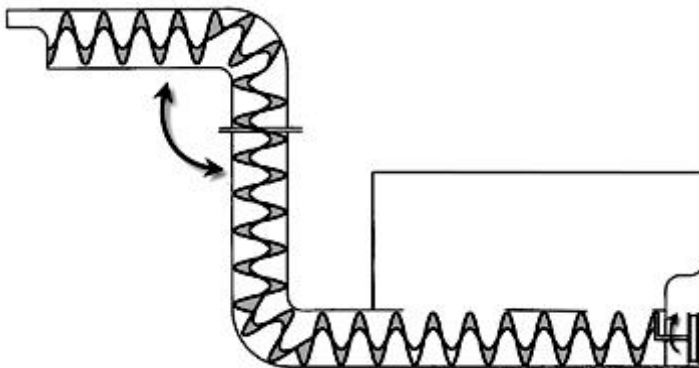

**B65G 33/18**

with multiple screws in parallel arrangements {, e.g. concentric}

**Definition statement**

*This place covers:*

Illustrative example of subject matter classified in this group:

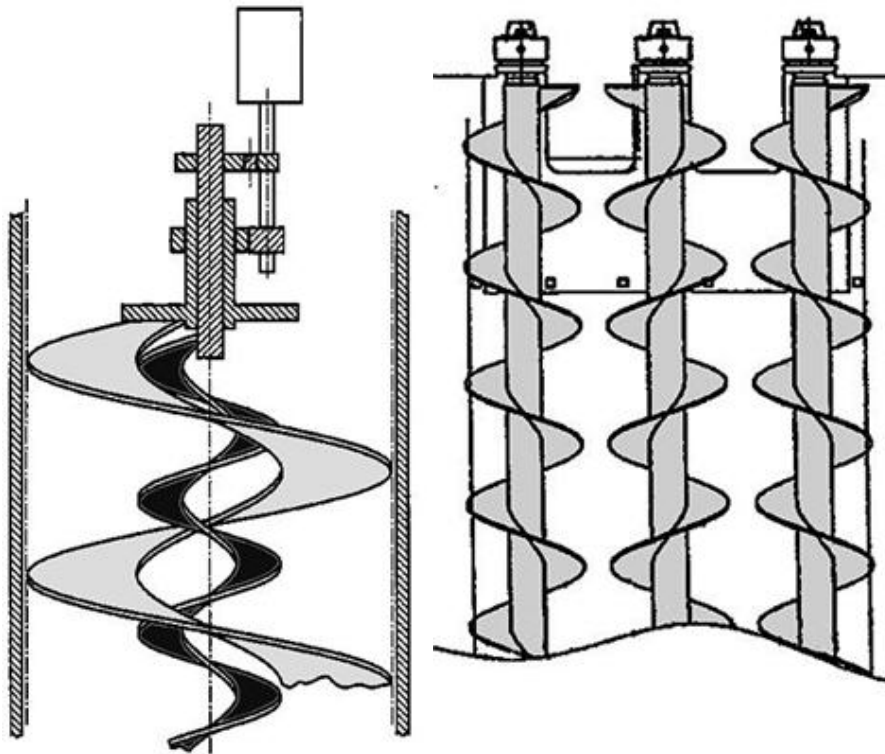



## B65G 33/20

the housing being rotatable relative to the screw

### Definition statement

*This place covers:*

Illustrative example of subject matter classified in this group:

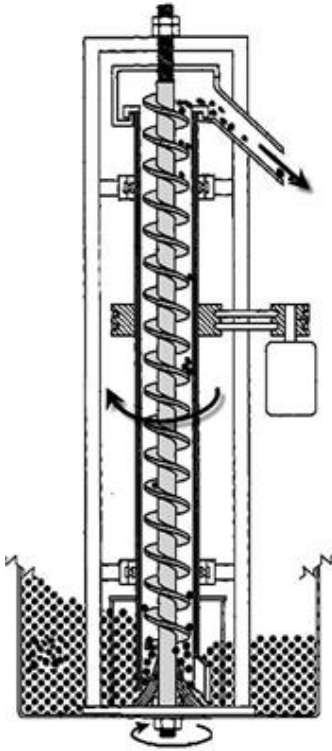



**B65G 33/22**

with means for retarding material flow at the delivery end of the housing

**Definition statement**

*This place covers:*

Illustrative example of subject matter classified in this group:

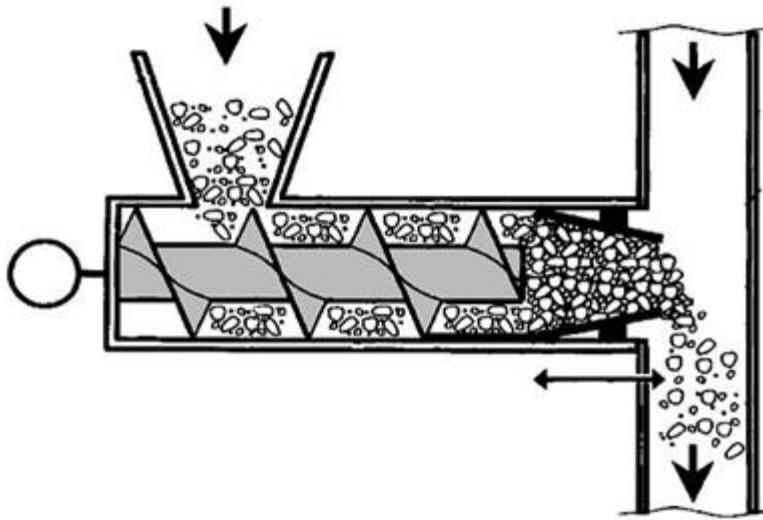
**B65G 33/26**

**Screws**

**Definition statement**

*This place covers:*

Illustrative example of subject matter classified in this group:

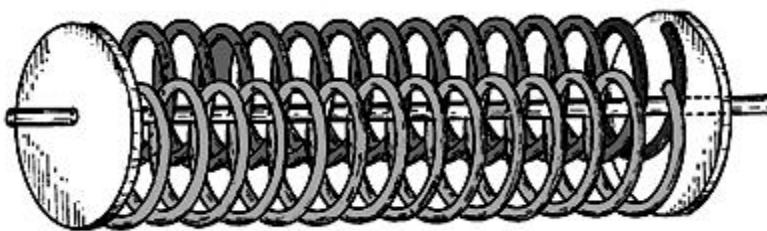
**References****Informative references**

*Attention is drawn to the following places, which may be of interest for search:*

Manufacture of screws	<a href="#">B21C 37/26</a>
As gearing elements	<a href="#">F16H 25/20</a>

## B65G 33/265

{with a continuous helical surface (flexible screws [B65G 33/16](#))}

### Definition statement

*This place covers:*

Illustrative example of subject matter classified in this group:

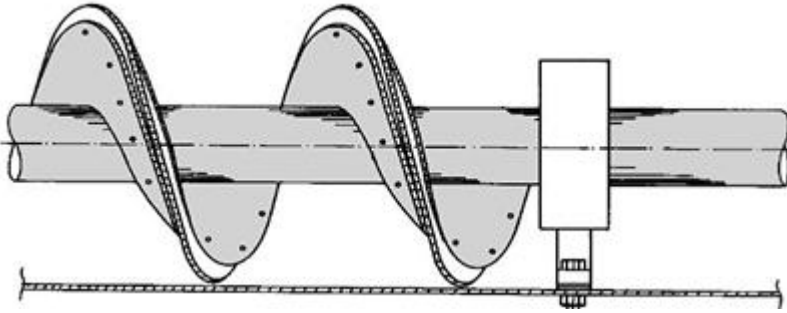

## B65G 33/30

with a discontinuous helical surface

### Definition statement

*This place covers:*

Illustrative example of subject matter classified in this group:

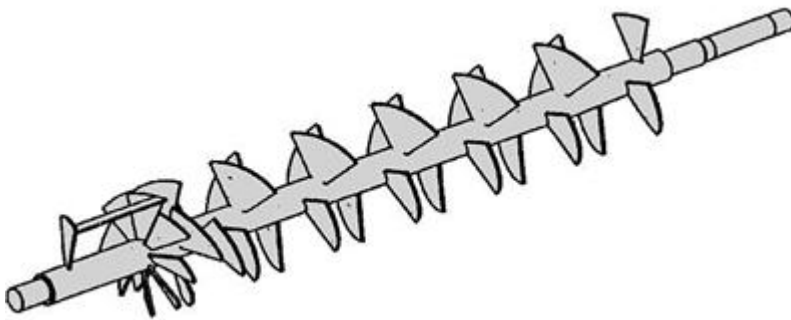

## B65G 33/32

**Adaptations of bearings or couplings for supporting and connecting screws**  
([B65G 33/16](#) takes precedence)

### Definition statement

*This place covers:*

Illustrative example of subject matter classified in this group:

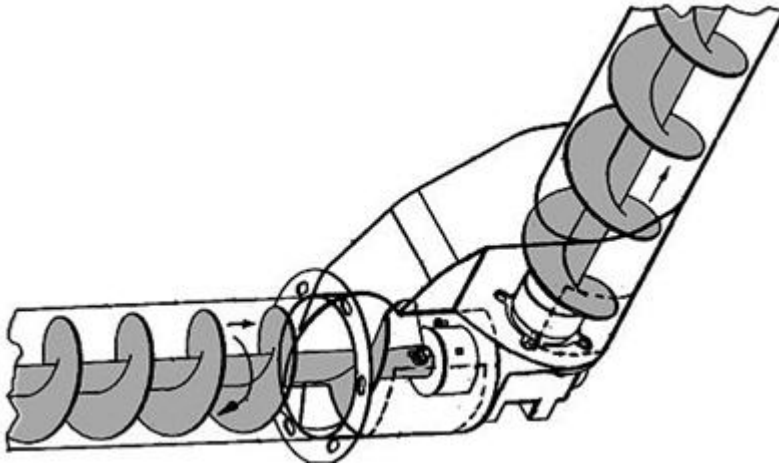

### References

#### Informative references

Attention is drawn to the following places, which may be of interest for search:

Auger couplers	<a href="#">B60P 1/40</a>
----------------	---------------------------

## B65G 33/34

**Applications of driving gear**

### Definition statement

*This place covers:*

Illustrative example of subject matter classified in this group:

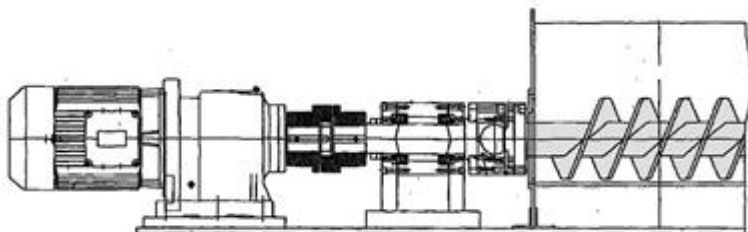

## B65G 33/36

for rotating housing and screw at different speeds

### Definition statement

*This place covers:*

Illustrative example of subject matter classified in this group:

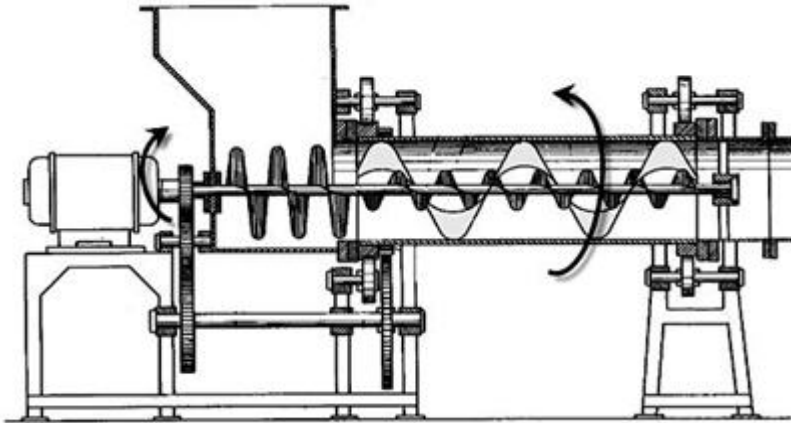

## B65G 33/38

for effecting simultaneous rotation and reciprocation of screw

### Definition statement

*This place covers:*

Illustrative example of subject matter classified in this group:

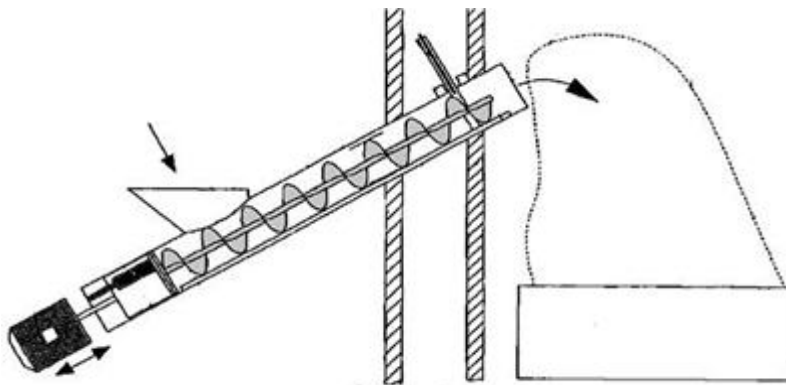

## B65G 35/00

### Mechanical conveyors not otherwise provided for

#### Definition statement

*This place covers:*

Illustrative example of subject matter classified in this group:

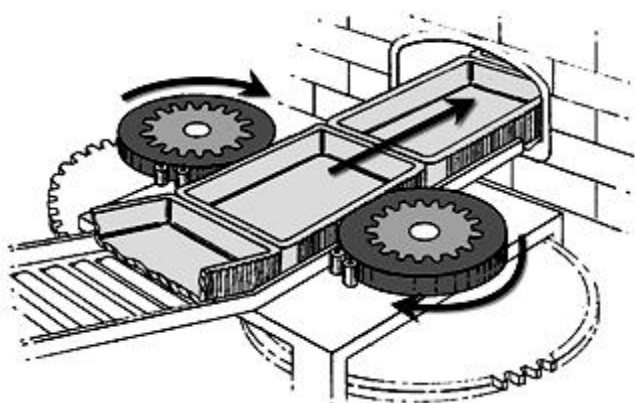
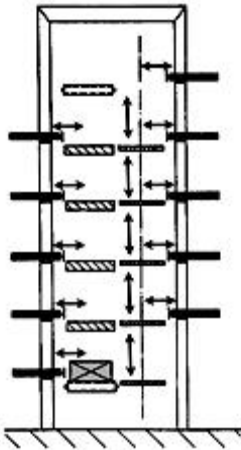
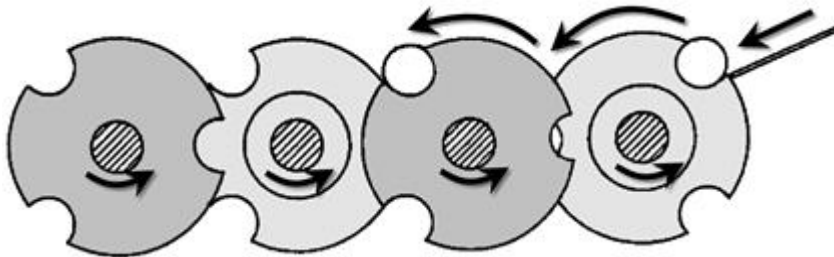

#### References

##### Informative references

*Attention is drawn to the following places, which may be of interest for search:*

Feeding or discharging conveyors by devices incorporated in, or operatively associated with, conveyors	<a href="#">B65G 47/00</a>
Movement in one direction, substantially outwards	<a href="#">B65G 47/1471</a>

Loading or unloading	<a href="#">B65G 65/00</a>
Railway systems	<a href="#">B61B</a>

## B65G 35/005

{with peristaltic propulsion along a flexible tube}

### Definition statement

*This place covers:*

Illustrative example of subject matter classified in this group:

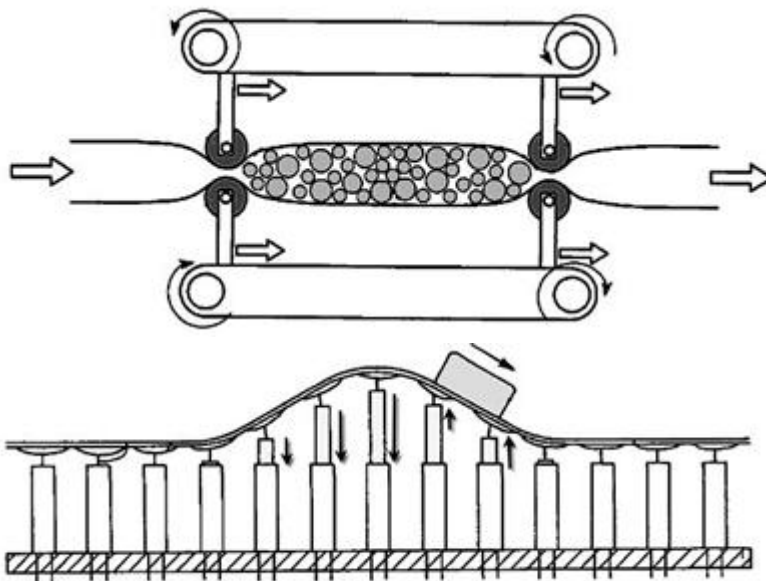

**B65G 35/02**

comprising an endless traction element, e.g. a belt, arranged to roll cylindrical articles over a supporting surface

**Definition statement**

*This place covers:*

Illustrative example of subject matter classified in this group:

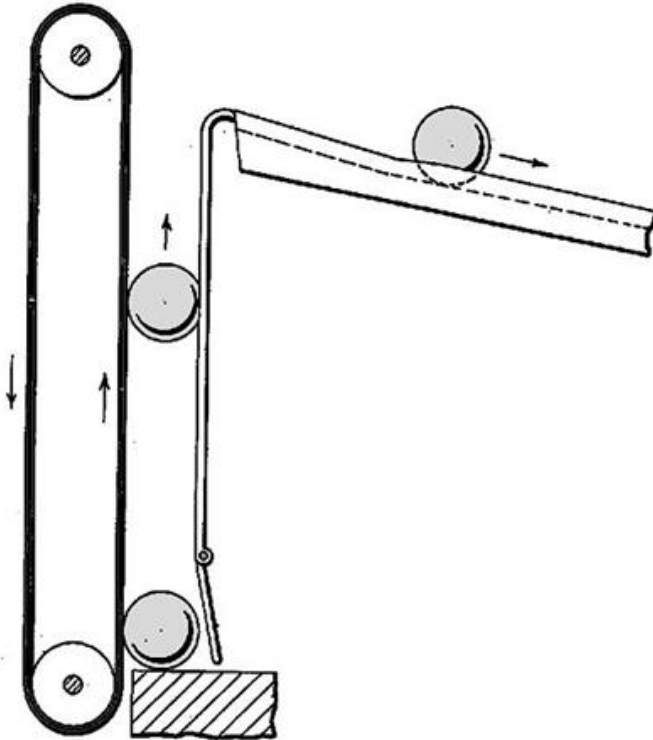
**B65G 35/04**

comprising a flexible load carrier, e.g. a belt, which is wound up at one end and paid out at the other (reciprocating belt conveyors [B65G 25/06](#))

**Definition statement**

*This place covers:*

Illustrative example of subject matter classified in this group:

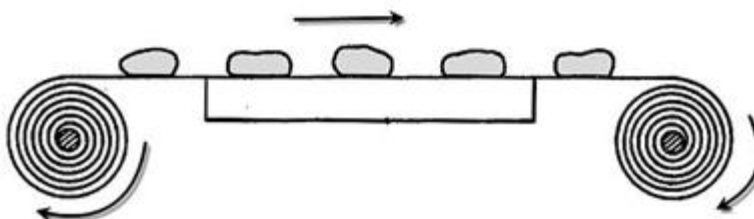

## References

### Limiting references

*This place does not cover:*

Reciprocating belt conveyors	<a href="#">B65G 25/06</a>
------------------------------	----------------------------

## B65G 35/06

comprising a load-carrier moving along a path, e.g. a closed path, and adapted to be engaged by any one of a series of traction elements spaced along the path (effecting drive at two or more points spaced along the length of an endless conveyor [B65G 23/32](#))

### Definition statement

*This place covers:*

Illustrative example of subject matter classified in this group:

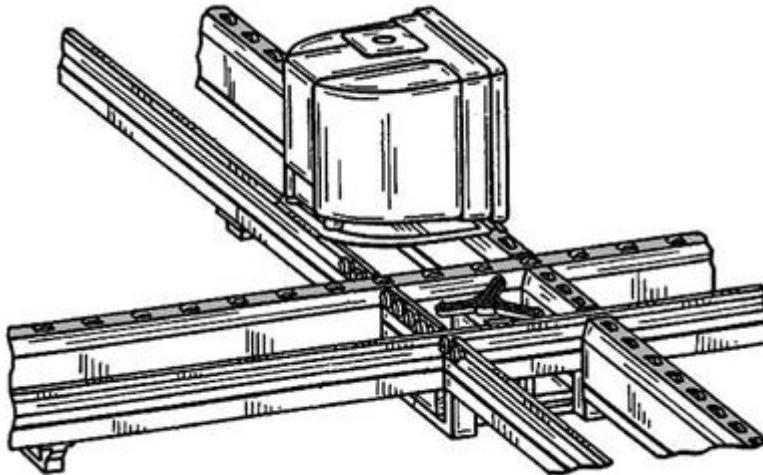

## References

### Limiting references

*This place does not cover:*

Effecting drive at two or more points spaced along the length of an endless conveyor	<a href="#">B65G 23/32</a>
--------------------------------------------------------------------------------------	----------------------------

### Informative references

*Attention is drawn to the following places, which may be of interest for search:*

Comprising load carriers resting on the traction element	<a href="#">B65G 17/002</a>
Only one traction element in the closed path	<a href="#">B65G 19/02</a>
Details, components, or accessories for machine tools, e.g. arrangements for copying or controlling	<a href="#">B23Q</a>



## B65G 35/063

{the traction element being a rotating bar or tube}

### Definition statement

*This place covers:*

Only for independent load carriers.

Illustrative example of subject matter classified in this group:

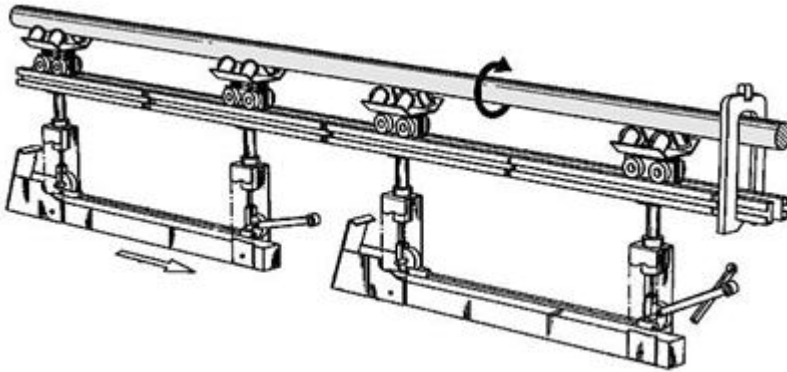

## B65G 35/066

{the bar or the tube being provided with a helical or annular channel}

### Definition statement

*This place covers:*

Illustrative example of subject matter classified in this group:

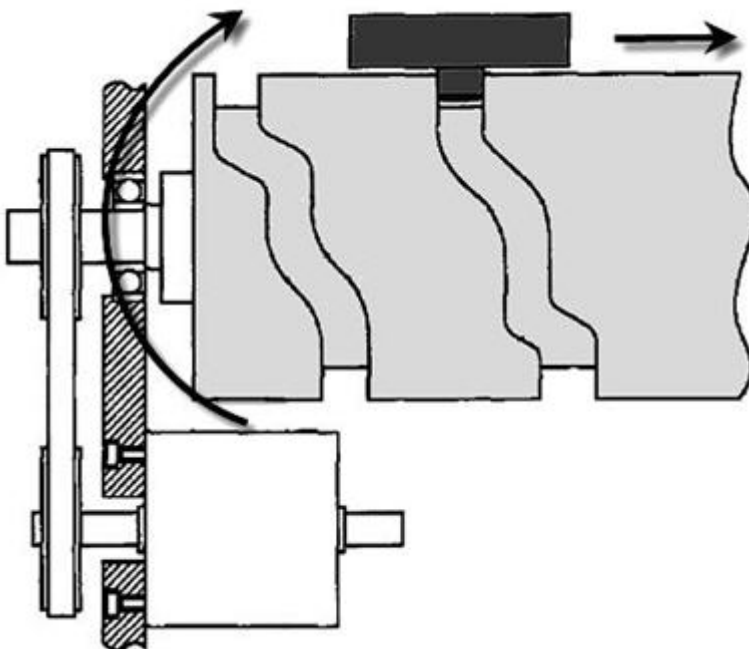

## B65G 35/08

comprising trains of unconnected load-carriers, e.g. belt sections, movable in a path, e.g. a closed path, adapted to contact each other and to be propelled by means arranged to engage each load-carrier in turn

### Definition statement

*This place covers:*

Independent load carriers pushing each other

Illustrative example of subject matter classified in this group:

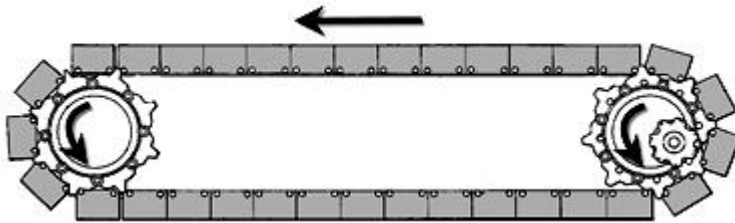

## B65G 37/00

Combinations of mechanical conveyors of the same kind, or of different kinds, of interest apart from their application in particular machines or use in particular manufacturing processes (series of co-operating belt conveyor units [B65G 15/22](#); series of co-operating chain conveyor units [B65G 17/26](#); sequence control of combined conveyors [B65G 43/10](#))

### Definition statement

*This place covers:*

Illustrative example of subject matter classified in this group:

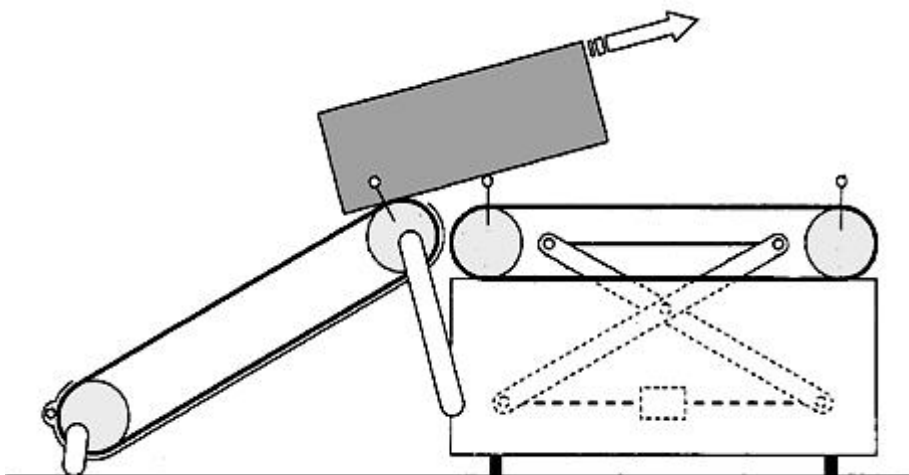

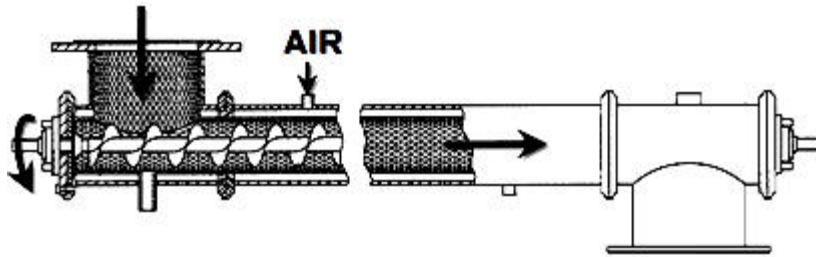

## References

### Limiting references

*This place does not cover:*

Series of co-operating belt conveyor units	<a href="#">B65G 15/22</a>
Series of co-operating chain conveyor units	<a href="#">B65G 17/26</a>
Sequence control of combined conveyors	<a href="#">B65G 43/10</a>

### Application-oriented references

*Examples of places where the subject matter of this place is covered when specially adapted, used for a particular purpose, or incorporated in a larger system:*

Feeding or discharging conveyors by devices incorporated in, or operatively associated with, conveyors	<a href="#">B65G 47/00</a>
Specially adapted for handling radioactive materials	<a href="#">G21</a>

### Informative references

*Attention is drawn to the following places, which may be of interest for search:*

Mechanical storage devices	<a href="#">B65G 1/04</a>
Loading or unloading	<a href="#">B65G 65/00</a>

## B65G 37/005

{comprising two or more co-operating conveying elements with parallel longitudinal axes (the conveying elements being endless surfaces [B65G 15/10](#))}

### Definition statement

*This place covers:*

Illustrative example of subject matter classified in this group:

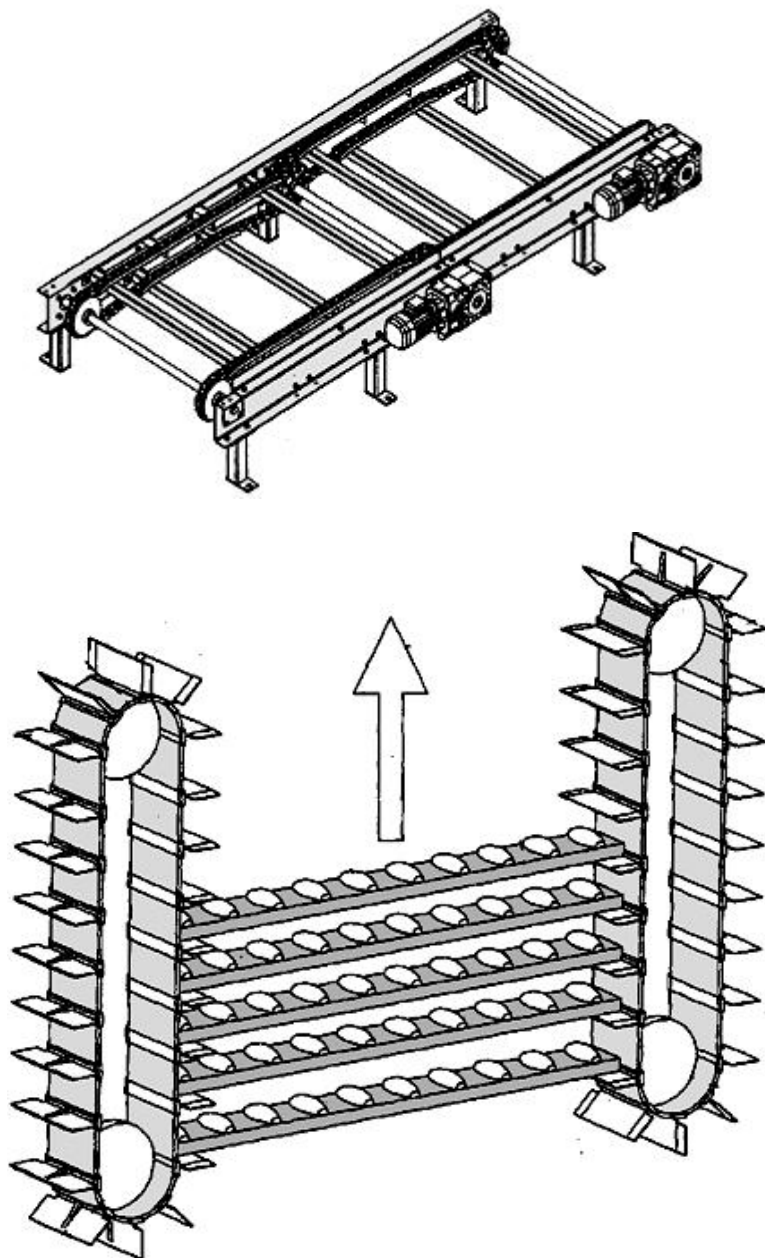

## References

### Limiting references

*This place does not cover:*

Parallel conveying belts, wherein the articles is in direct contact with the belts	<a href="#">B65G 15/10</a>
------------------------------------------------------------------------------------	----------------------------

## B65G 37/02

### Flow-sheets for conveyor combinations in warehouses, magazines or workshops

#### Definition statement

*This place covers:*

Illustrative example of subject matter classified in this group:

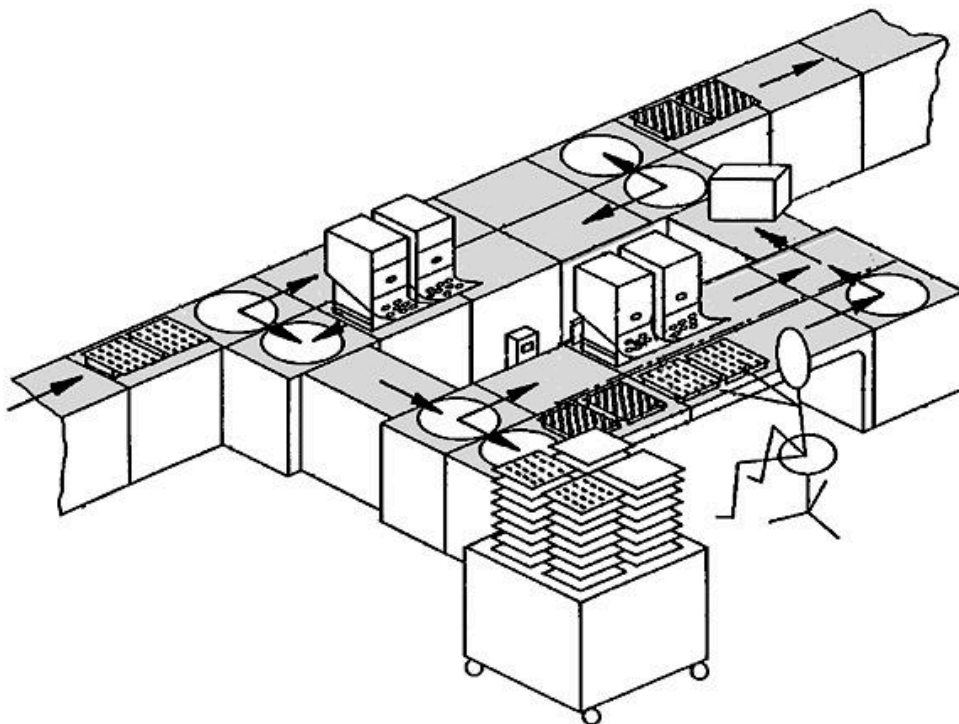

## B65G 39/00

Rollers, e.g. drive rollers, or arrangements thereof incorporated in roller-ways or other types of mechanical conveyors (driving gear for rollers of roller-ways [B65G 13/06](#))

### Definition statement

*This place covers:*

Illustrative example of subject matter classified in this group:

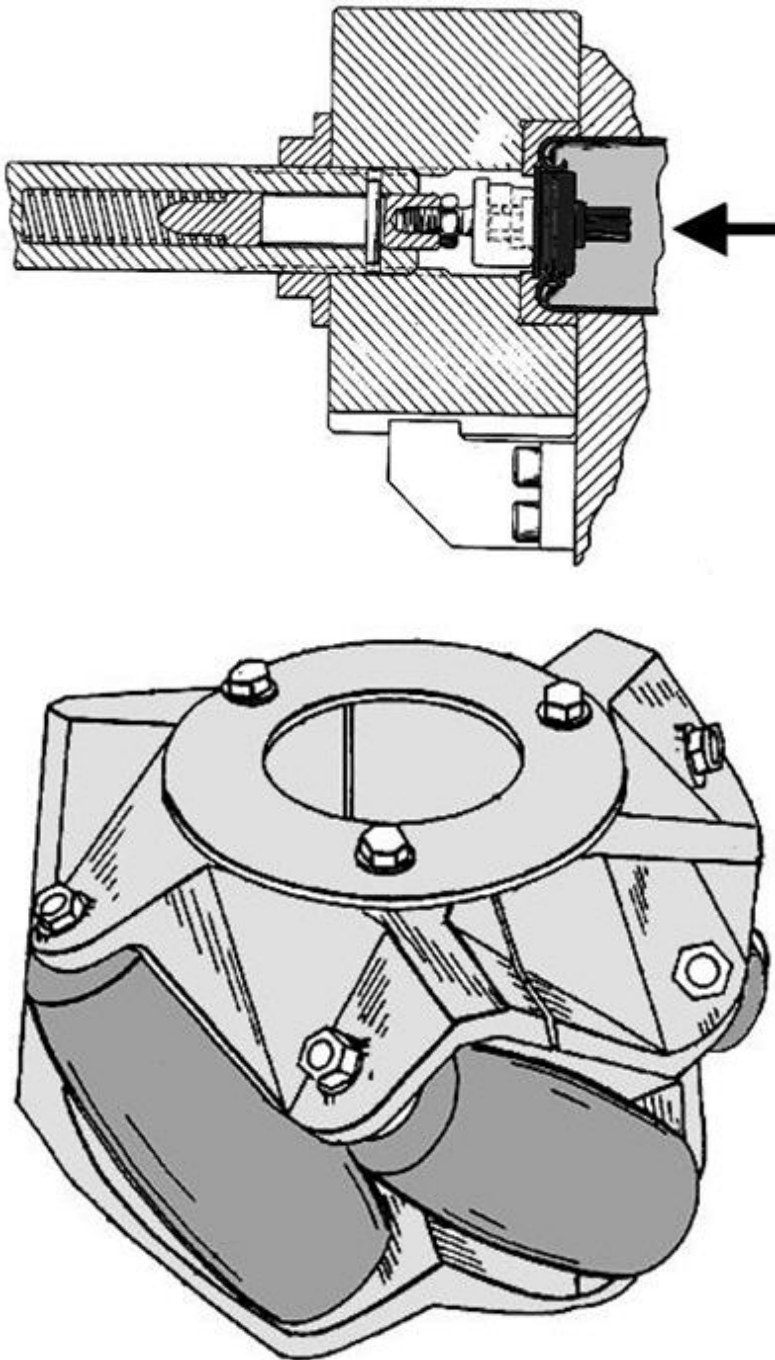



## References

### Limiting references

*This place does not cover:*

Driving gear for rollers of roller-ways	<a href="#">B65G 13/06</a>
-----------------------------------------	----------------------------

### Application-oriented references

*Examples of places where the subject matter of this place is covered when specially adapted, used for a particular purpose, or incorporated in a larger system:*

Drive rollers of endless conveyors	<a href="#">B65G 23/04</a>
Arrangement of rollers in metal-rolling equipment	<a href="#">B21B 39/10</a>

### Informative references

*Attention is drawn to the following places, which may be of interest for search:*

Rollers for facilitating the change of the belt or of a roller of a belt conveyor	<a href="#">B65G 15/00</a>
Omni-rolls	<a href="#">B65G 2207/34</a>
Manufacturing rollers	<a href="#">B29D 99/0032</a>
Safety (e.g. for heat protection, bearing damages)	<a href="#">F16C 19/52</a>
Friction members	<a href="#">F16H 55/32</a>

## B65G 39/02

### Adaptations of individual rollers and supports therefor

#### Definition statement

*This place covers:*

The construction of the roller itself

Illustrative example of subject matter classified in this group:

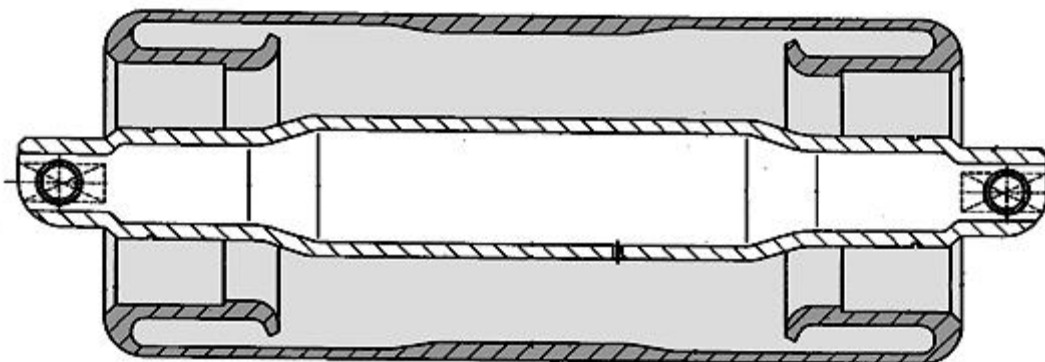

## **B65G 39/025**

**{having spherical roller elements}**

### **Definition statement**

*This place covers:*

Illustrative example of subject matter classified in this group:



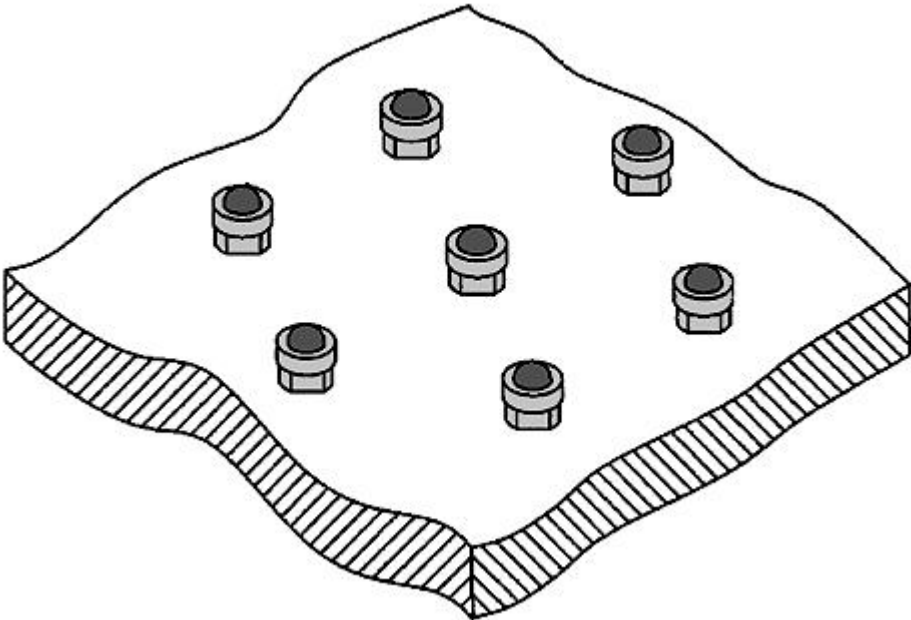
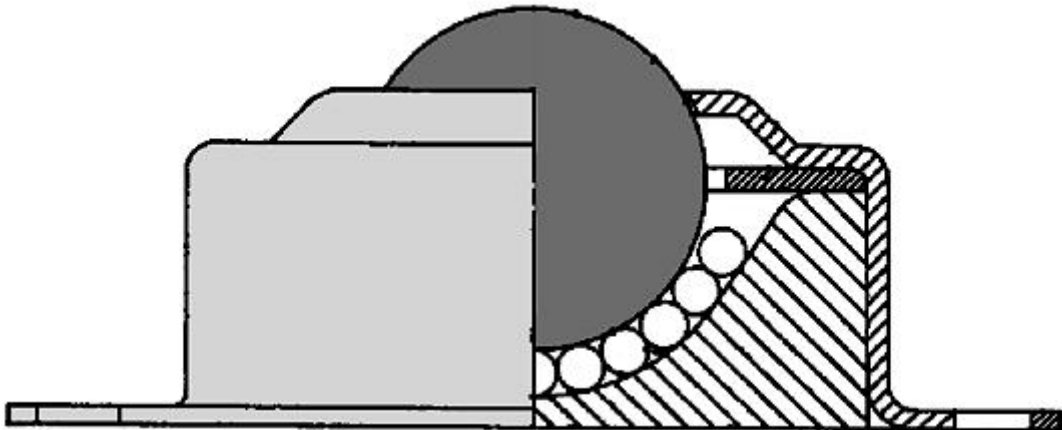
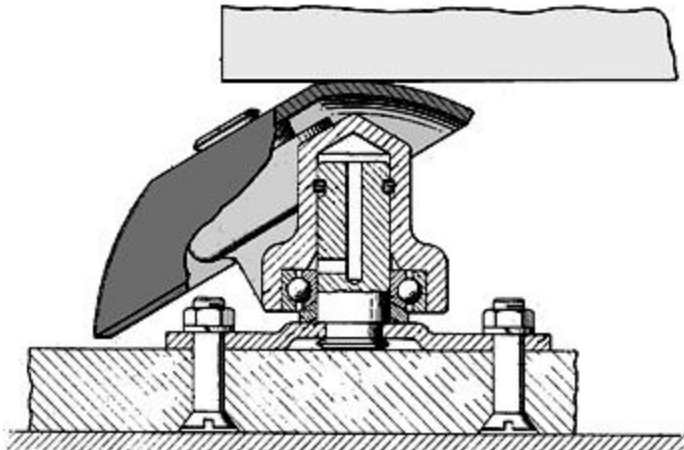

**B65G 39/04**

the rollers comprising a number of roller forming elements mounted on a single axle

**Definition statement**

*This place covers:*

Illustrative example of subject matter classified in this group:

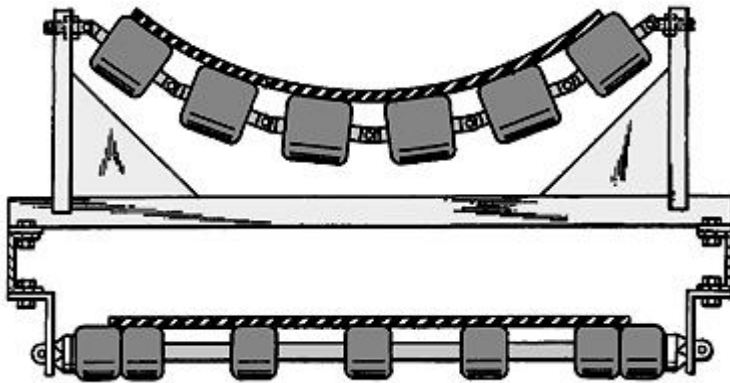
**References****Informative references**

*Attention is drawn to the following places, which may be of interest for search:*

For the detail of the roller attachment	<a href="#">B65G 39/02</a>
-----------------------------------------	----------------------------

**B65G 39/06**

the roller sleeves being shock-absorbing, e.g. formed by helically-wound wires

**Definition statement**

*This place covers:*

Illustrative example of subject matter classified in this group:

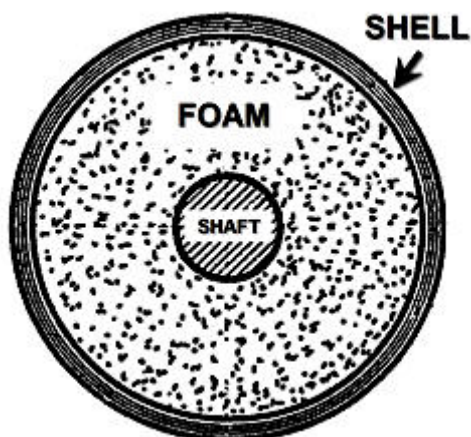

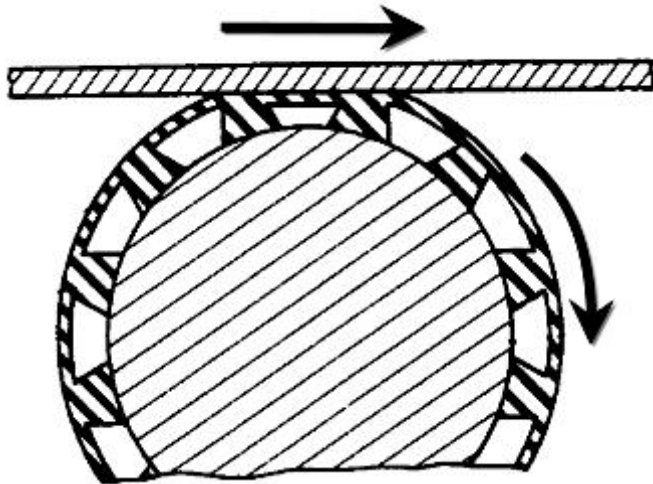

### B65G 39/07

#### Other adaptations of sleeves

#### Definition statement

*This place covers:*

Illustrative example of subject matter classified in this group:

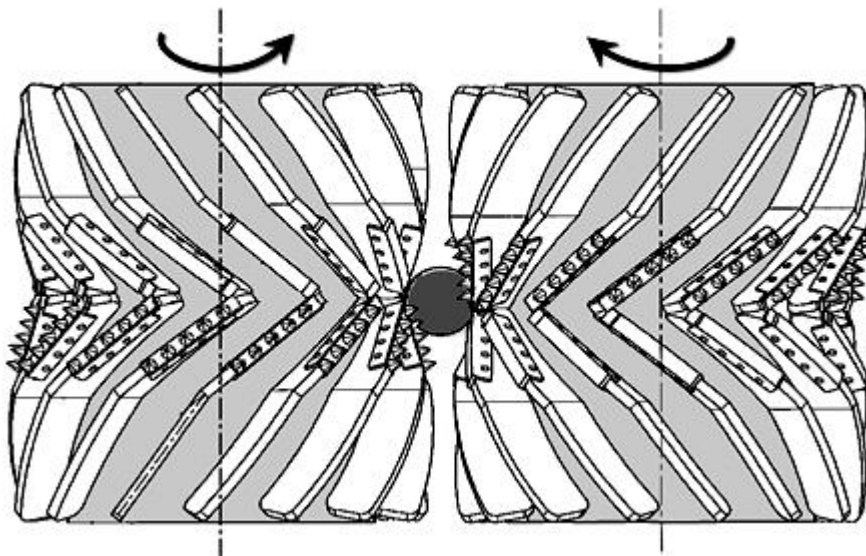

#### References

#### Limiting references

*This place does not cover:*

For cleaning belts,	<a href="#">B65G 39/073</a>
For general cleaning purposes	<a href="#">B08B 1/32</a>

## B65G 39/071

for aligning belts or sheets

### Definition statement

*This place covers:*

Illustrative example of subject matter classified in this group:

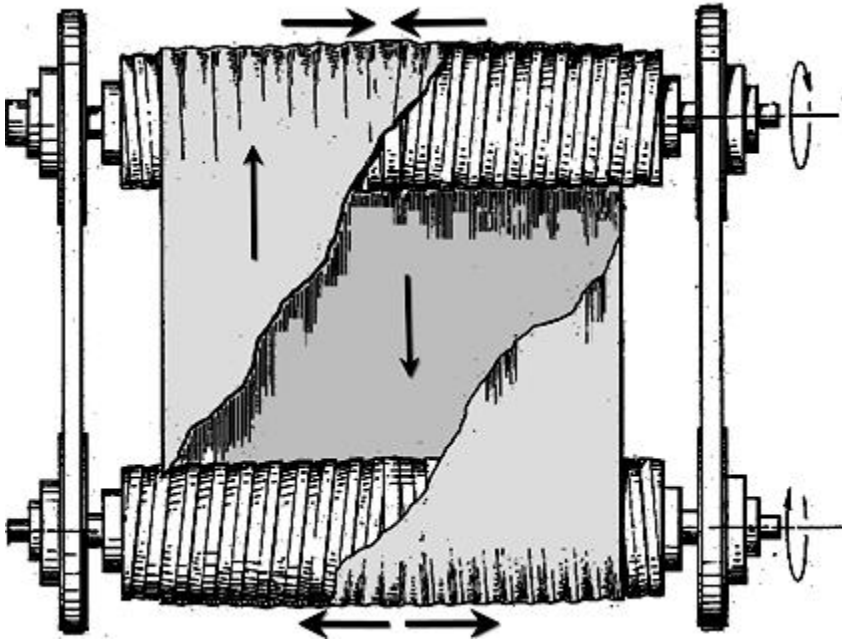

### References

#### *Informative references*

*Attention is drawn to the following places, which may be of interest for search:*

Roller support control for aligning the belt	<a href="#">B65G 39/16</a>
----------------------------------------------	----------------------------

## **B65G 39/073**

**for cleaning belts**

### **Definition statement**

*This place covers:*

Illustrative example of subject matter classified in this group:

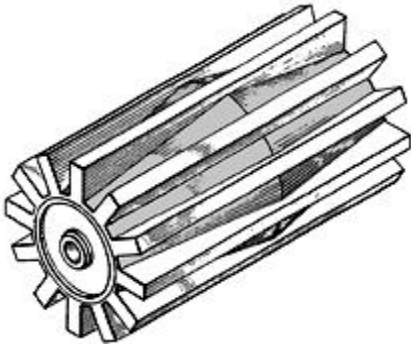

### **References**

#### ***Informative references***

*Attention is drawn to the following places, which may be of interest for search:*

Rotating bodies for general cleaning purposes	<a href="#">B08B 1/32</a>
-----------------------------------------------	---------------------------

## B65G 39/08

the rollers being magnetic

### Definition statement

*This place covers:*

Illustrative example of subject matter classified in this group:

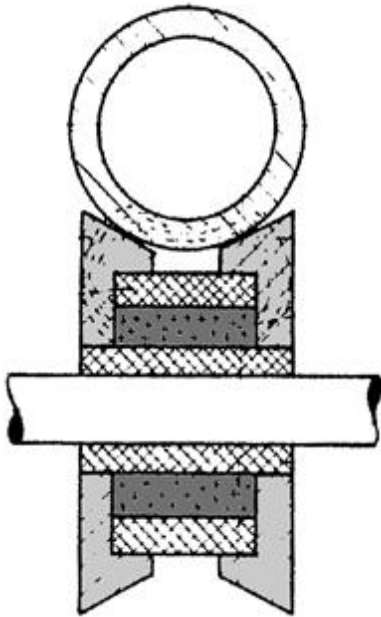

### References

#### *Application-oriented references*

*Examples of places where the subject matter of this place is covered when specially adapted, used for a particular purpose, or incorporated in a larger system:*

In magnetic belt separators	<a href="#">B03C 1/00</a>
-----------------------------	---------------------------

## B65G 39/09

### Arrangements of bearing or sealing means

#### Definition statement

*This place covers:*

Illustrative example of subject matter classified in this group:

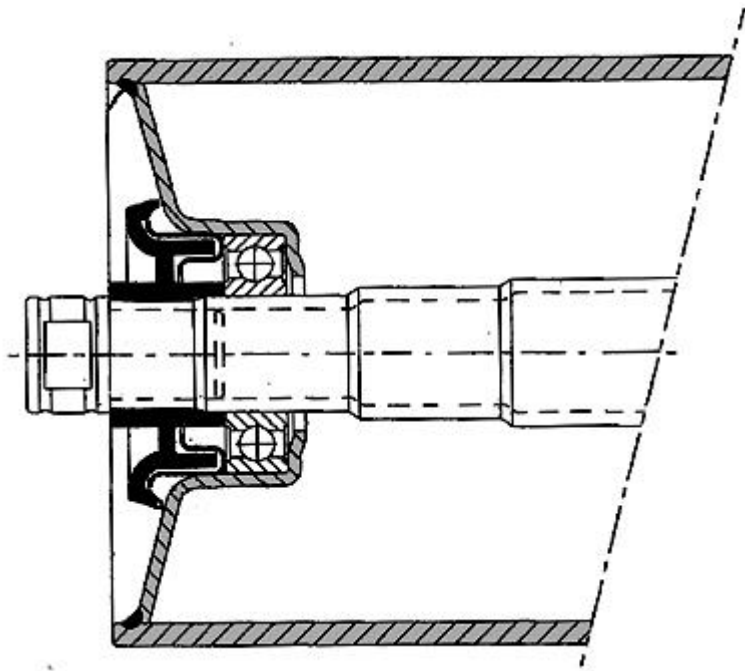

## B65G 39/10

### Arrangements of rollers (on a single axle [B65G 39/04](#))

#### Definition statement

*This place covers:*

Rollers fixed (not adjustable) to the frame



Illustrative example of subject matter classified in this group:

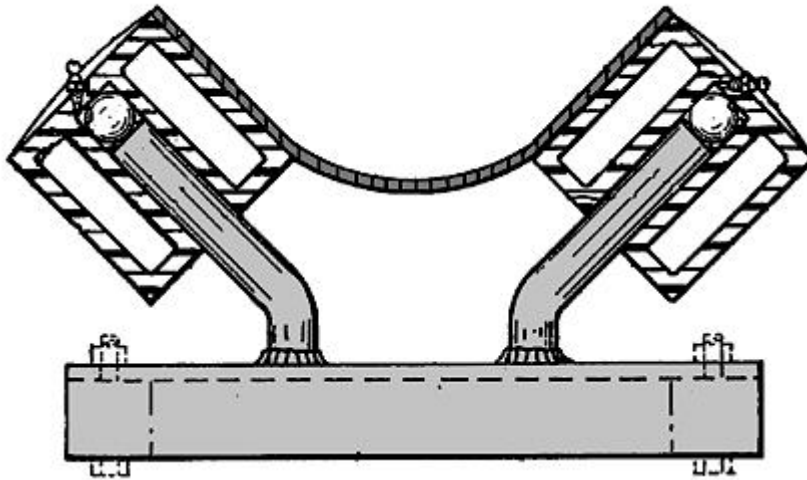

## **B65G 39/12**

**mounted on framework**

### **Definition statement**

*This place covers:*

The mounting of the roller on the frame

Illustrative example of subject matter classified in this group:

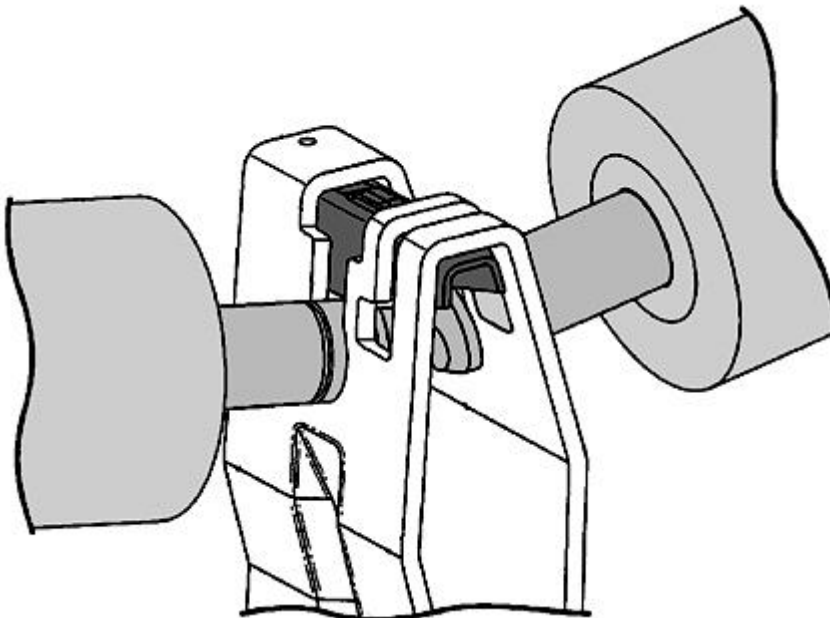



**B65G 39/125****{for selectively adjusting troughing of the conveying belt}****Definition statement***This place covers:*

Illustrative example of subject matter classified in this group:

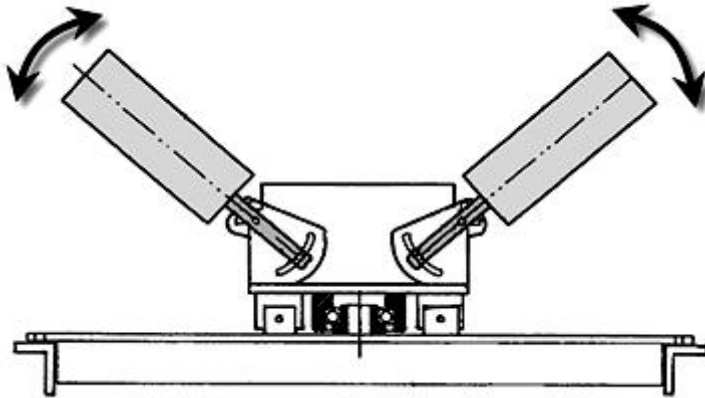
**References****Informative references***Attention is drawn to the following places, which may be of interest for search:*

For bulk material,	<a href="#">B65G 21/2081</a>
--------------------	------------------------------

**B65G 39/14****Spring-supported sets, e.g. permitting troughing of a load-carrying belt****Definition statement***This place covers:*

Illustrative example of subject matter classified in this group:

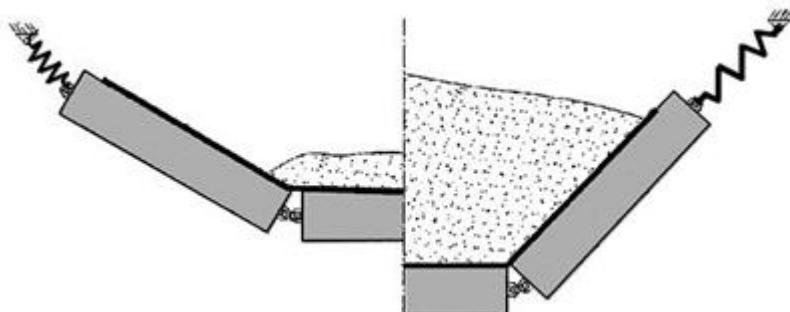
**References****Informative references***Attention is drawn to the following places, which may be of interest for search:*

Changing a roller of a belt conveyor	<a href="#">B65G 15/00</a>
--------------------------------------	----------------------------

## **B65G 39/145**

{attached to ties formed by longitudinal cables or ropes}

### **Definition statement**

*This place covers:*

Illustrative example of subject matter classified in this group:

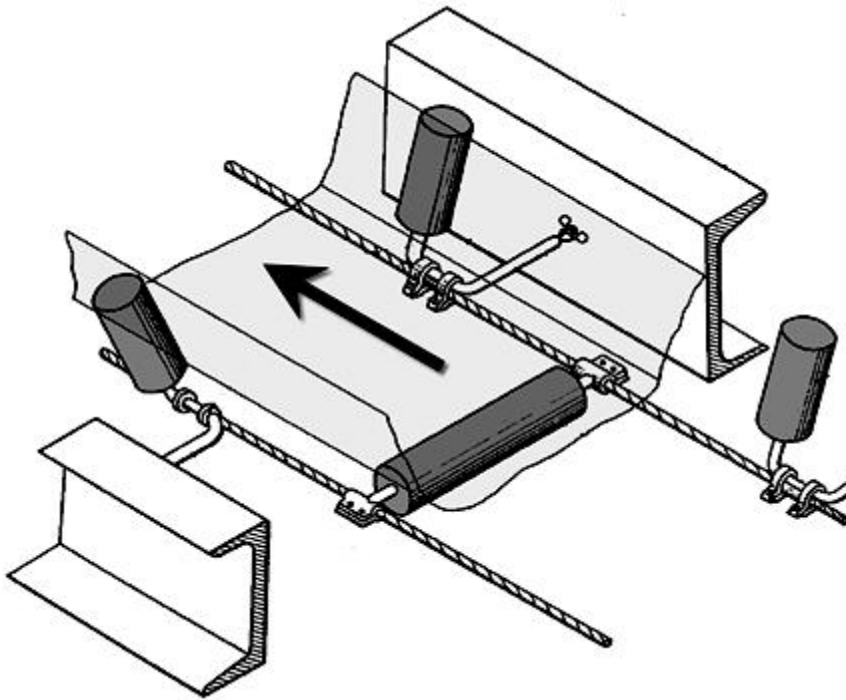

### **Special rules of classification**

[B65G 39/145](#) should not be considered as a subclass of [B65G 39/14](#)

**B65G 39/16****for aligning belts or chains****Definition statement**

*This place covers:*

Illustrative example of subject matter classified in this group:

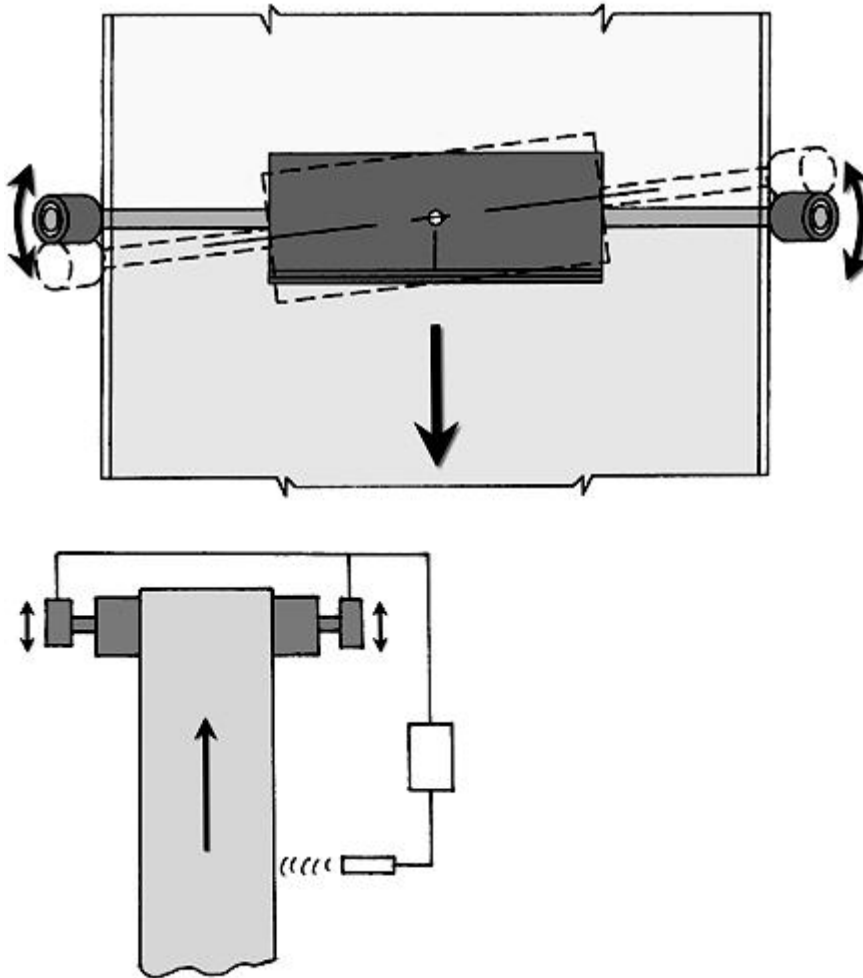
**References****Informative references**

*Attention is drawn to the following places, which may be of interest for search:*

Guides for sliding belts	<a href="#">B65G 15/62</a>
Lateral guidance means for bulk material	<a href="#">B65G 21/2081</a>
For aligning tapes or webs	<a href="#">B65H</a>

**B65G 39/18****for guiding loads****Definition statement***This place covers:*

Illustrative example of subject matter classified in this group:

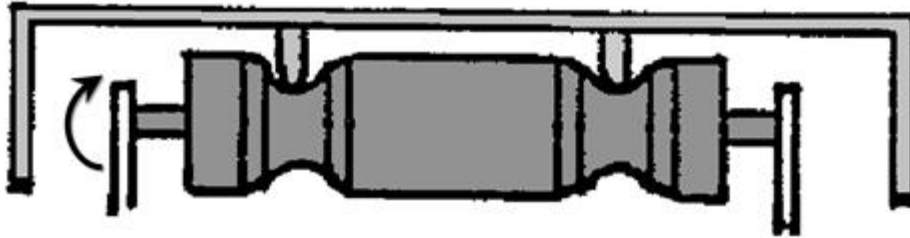
**References****Limiting references***This place does not cover:*

Comprising elements movable in the direction of load-transport	<a href="#">B65G 21/2054</a>
The construction of the roller itself	<a href="#">B65G 39/00</a>

**B65G 39/20****attached to moving belts or chains****Definition statement***This place covers:*

Illustrative example of subject matter classified in this group:

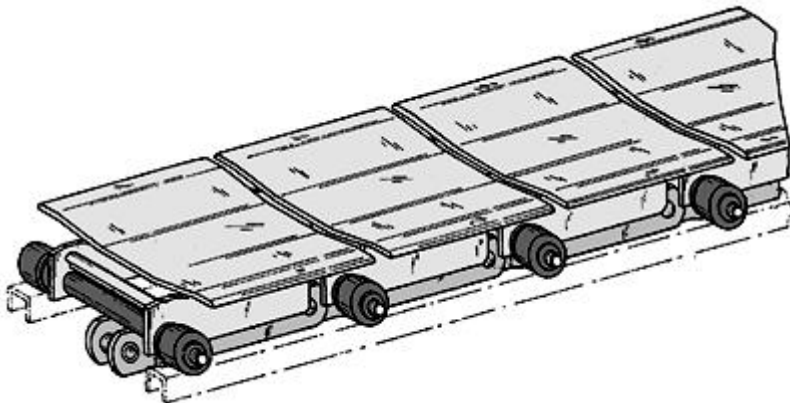

## References

### Informative references

Attention is drawn to the following places, which may be of interest for search:

Belts	<a href="#">B65G 15/30</a>
Chains	<a href="#">B65G 17/44</a>

## B65G 41/00

**Supporting frames or bases for conveyors as a whole, e.g. transportable conveyor frames**

### Definition statement

*This place covers:*

Where in the whole conveying unit is on a base or a supporting unit

Illustrative example of subject matter classified in this group:

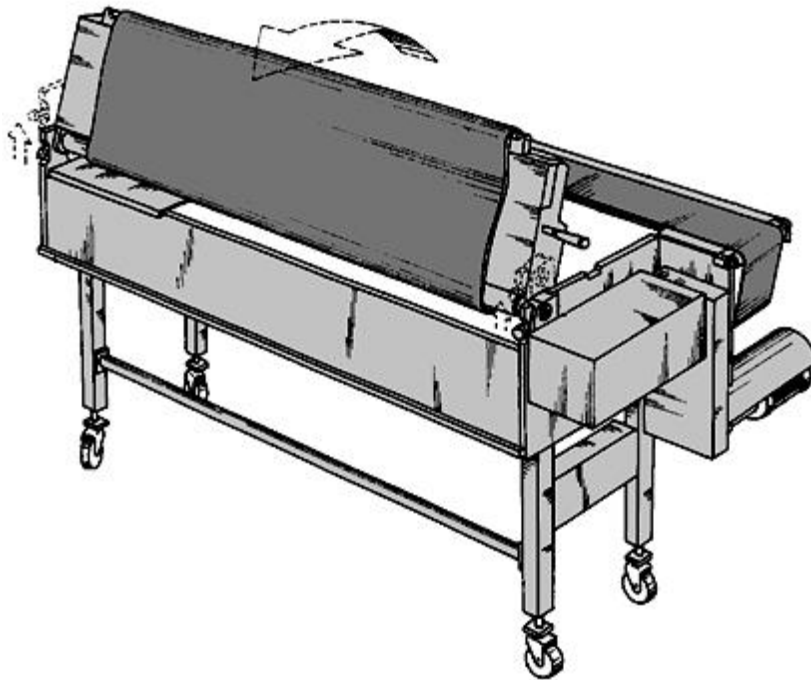

## B65G 41/001

{with the conveyor adjustably mounted on the supporting frame or base}

## References

### Informative references

Attention is drawn to the following places, which may be of interest for search:

Piling/unpiling bulk	<a href="#">B65G 65/28</a>
----------------------	----------------------------

**B65G 41/002****{Pivotably mounted}****Definition statement***This place covers:*

Illustrative example of subject matter classified in this group:

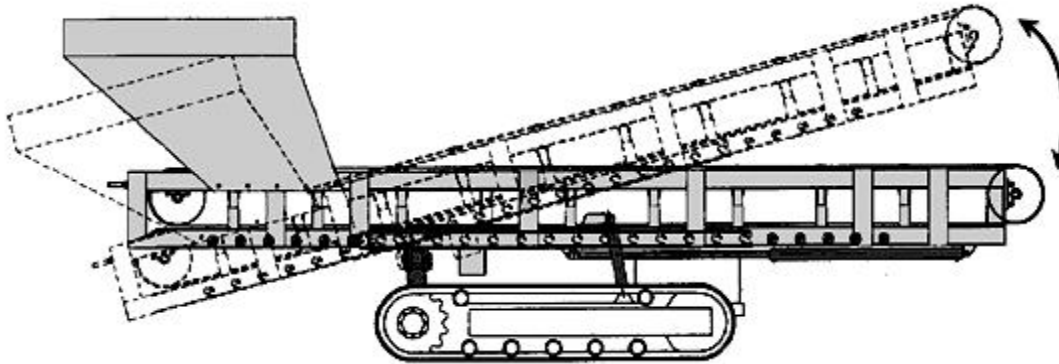
**References****Informative references***Attention is drawn to the following places, which may be of interest for search:*

To adjust the position of the conveyor as a whole	<a href="#">B65G 21/12</a>
---------------------------------------------------	----------------------------

**B65G 41/003****{mounted for linear movement only}****Definition statement***This place covers:*

Illustrative example of subject matter classified in this group:

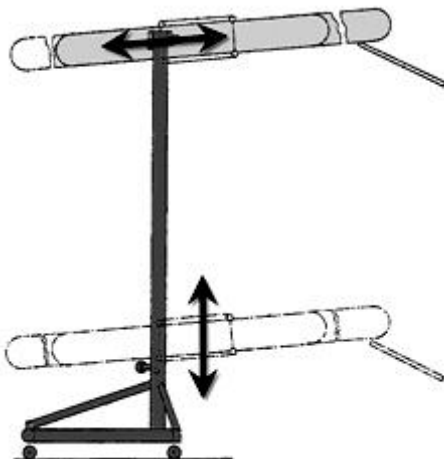

## References

### *Informative references*

Attention is drawn to the following places, which may be of interest for search:

For telescopic arrangement	<a href="#">B65G 21/14</a> , <a href="#">B65G 13/12</a>
----------------------------	---------------------------------------------------------

## B65G 41/005

{mounted for both pivotal and linear movement}

### Definition statement

*This place covers:*

Illustrative example of subject matter classified in this group:

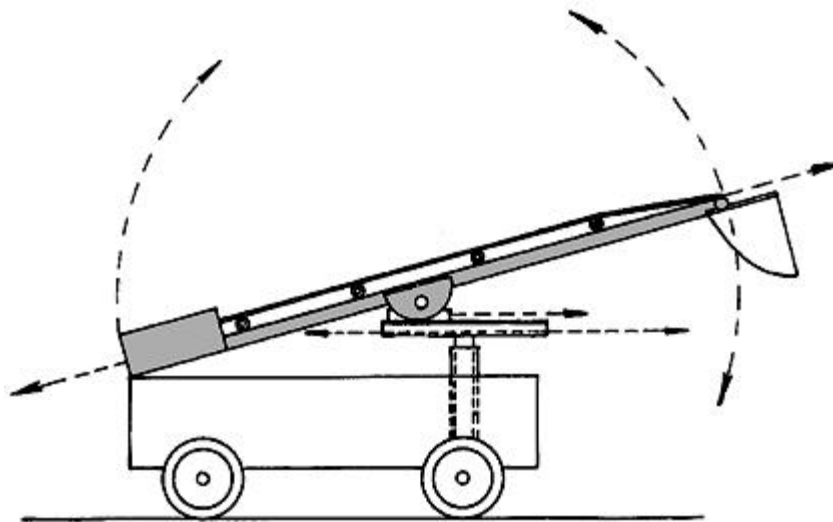

**B65G 41/006**

{with the conveyor not adjustably mounted on the supporting frame or base}

**Definition statement**

*This place covers:*

Illustrative example of subject matter classified in this group:

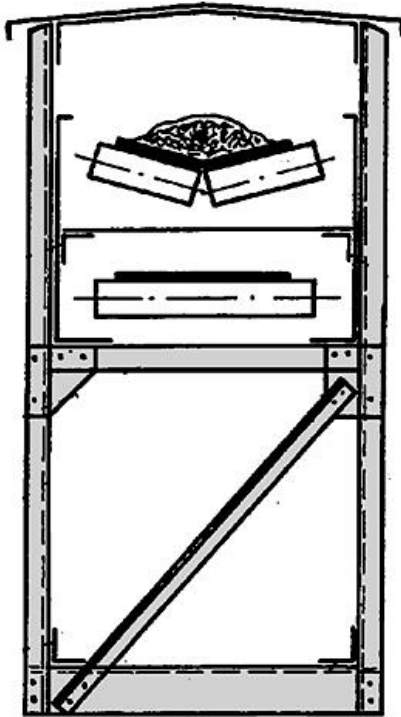
**References****Limiting references**

*This place does not cover:*

Supporting or protective framework consisting essentially of struts, ties, or like structural elements	<a href="#">B65G 21/02</a>
Supporting or protective framework constructed to facilitate rapid assembly or dismantling	<a href="#">B65G 21/06</a>



**B65G 41/007**

{Means for moving conveyor frames and control arrangements therefor  
([B65G 41/02](#) takes precedence)}

**Definition statement**

*This place covers:*

Illustrative example of subject matter classified in this group:

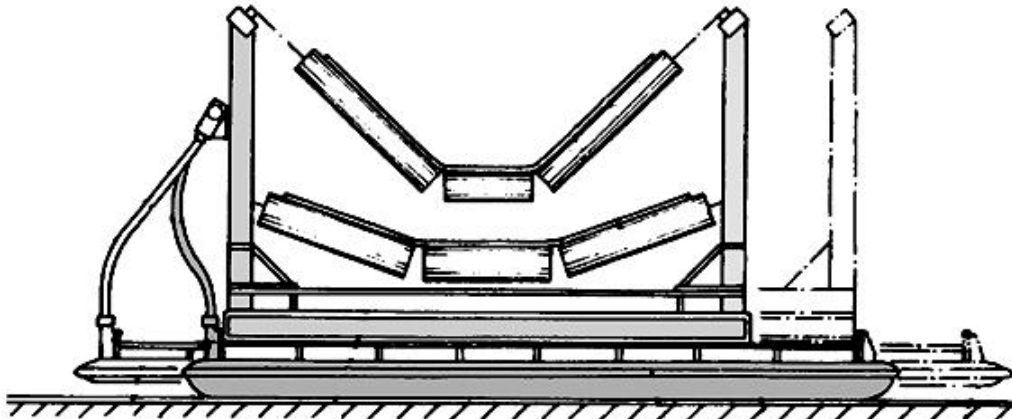
**References****Limiting references**

*This place does not cover:*

On wheels	<a href="#">B65G 41/008</a>
On wheels on rails	<a href="#">B65G 41/02</a>

**B65G 41/008**

{frames mounted on wheels or caterpillar (for movement on rail tracks  
[B65G 41/02](#))}

**Definition statement**

*This place covers:*

Illustrative example of subject matter classified in this group:

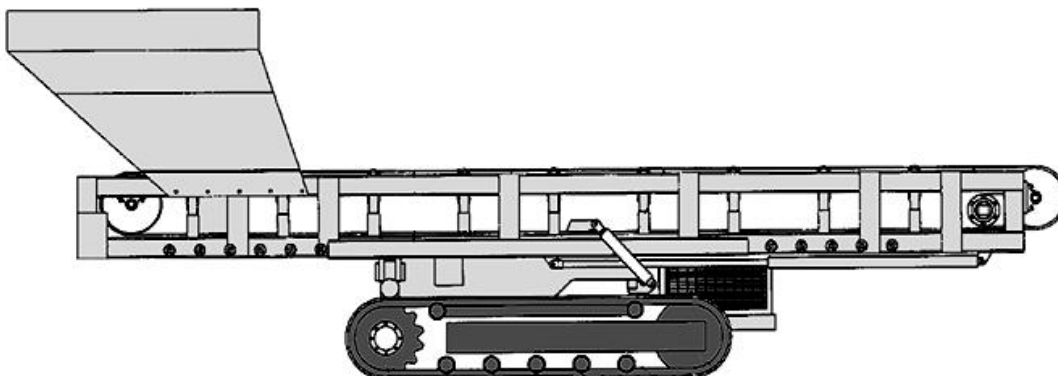

## B65G 41/02

### Frames mounted on wheels for movement on rail tracks

#### Definition statement

*This place covers:*

Illustrative example of subject matter classified in this group:

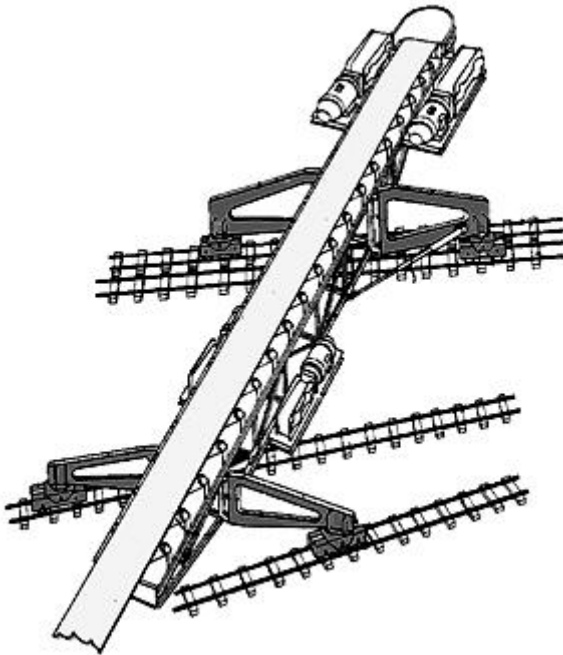

#### References

##### Informative references

*Attention is drawn to the following places, which may be of interest for search:*

Piling/unpiling bulk	<a href="#">B65G 65/28</a>
----------------------	----------------------------

## B65G 43/00

### Control devices, e.g. for safety, warning or fault-correcting

#### References

##### Application-oriented references

*Examples of places where the subject matter of this place is covered when specially adapted, used for a particular purpose, or incorporated in a larger system:*

For elevators, escalators or moving walkways	<a href="#">B66B</a>
----------------------------------------------	----------------------

##### Informative references

*Attention is drawn to the following places, which may be of interest for search:*

Inspection trolleys moving on belt or frame	<a href="#">B65G 15/00</a> , <a href="#">B65G 21/00</a>
Elements attached to a frame for the safety of people	<a href="#">B65G 21/00</a>

Antistatic features	<a href="#">B65G 2207/10</a>
Control devices in general	<a href="#">F16P</a> , <a href="#">G08B</a>
Safety devices, guards	<a href="#">F16P 1/005</a>
Controls in general	<a href="#">G05B</a>
Devices for preventing static electricity	<a href="#">H05F 3/00</a>

## **B65G 43/02**

**detecting dangerous physical condition of load carriers, e.g. for interrupting the drive in the event of overheating**

### **Definition statement**

*This place covers:*

Illustrative example of subject matter classified in this group:

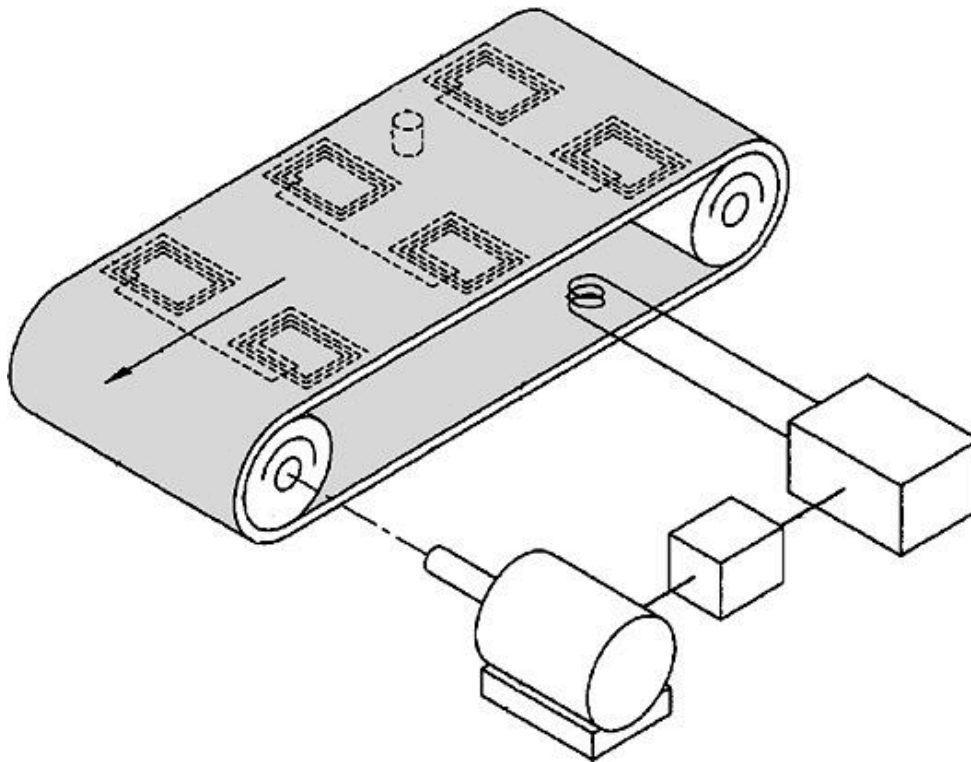

### **References**

#### **Informative references**

*Attention is drawn to the following places, which may be of interest for search:*

Testing transmission	<a href="#">G01M 13/02</a>
Impuls speed control	<a href="#">G01P</a> , <a href="#">G01D</a>
Electrical speed control	<a href="#">G05B</a>

**B65G 43/04**

detecting slip between driving element and load-carrier, e.g. for interrupting the drive {(B65G 43/02 takes precedence)}

**Definition statement**

*This place covers:*

Illustrative example of subject matter classified in this group:

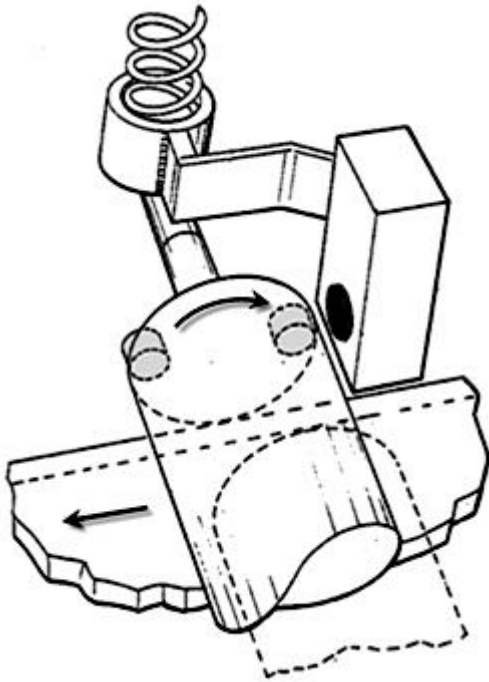
**B65G 43/06**

interrupting the drive in case of driving element breakage; Braking or stopping loose load-carriers

**Definition statement**

*This place covers:*

Illustrative example of subject matter classified in this group:

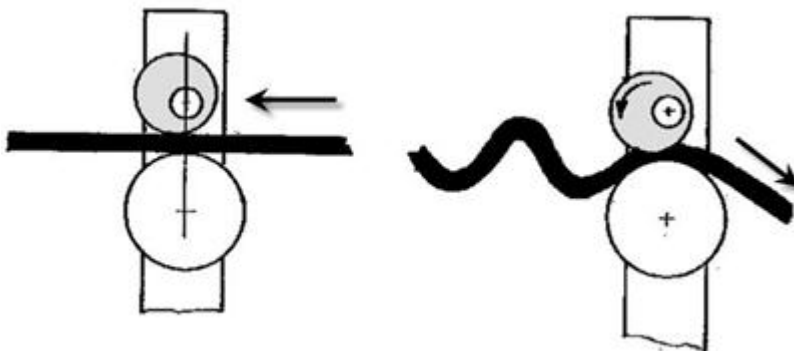

**B65G 43/08**

**Control devices operated by article or material being fed, conveyed or discharged {(and controlling the discharging devices [B65G 47/42](#))}**

**Definition statement**

*This place covers:*

Only in combination with the detection of articles or bulk

Illustrative example of subject matter classified in this group:

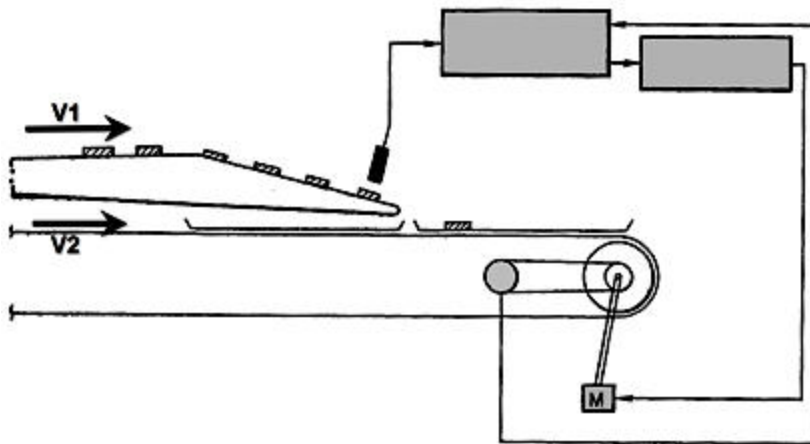
**References****Informative references**

Attention is drawn to the following places, which may be of interest for search:

Counting articles in a conveyor	<a href="#">G06M 7/04</a>
---------------------------------	---------------------------

**B65G 43/10**

**Sequence control of conveyors operating in combination**

**Definition statement**

*This place covers:*

Also: control of conveying modules over network bus or daisy chain

Illustrative example of subject matter classified in this group:



## References

### Informative references

Attention is drawn to the following places, which may be of interest for search:

Accumulating articles	<a href="#">B65G 47/268</a>
-----------------------	-----------------------------

## B65G 45/005

### {Cleaning conveyor screws}

#### Definition statement

This place covers:

Illustrative example of subject matter classified in this group:

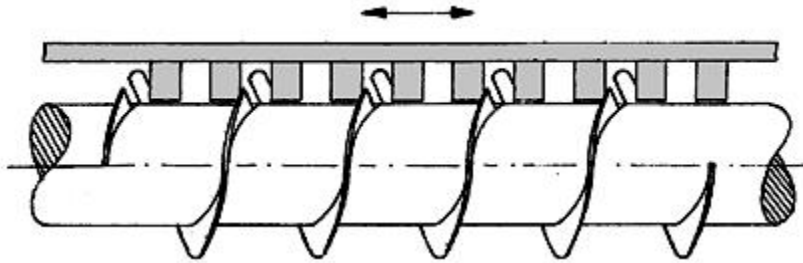

## References

### Informative references

Attention is drawn to the following places, which may be of interest for search:

Presses with screws	<a href="#">B30B 9/122</a> , <a href="#">B30B 11/248</a>
---------------------	----------------------------------------------------------

## B65G 45/02

### Lubricating devices

#### Definition statement

This place covers:

Illustrative example of subject matter classified in this group:

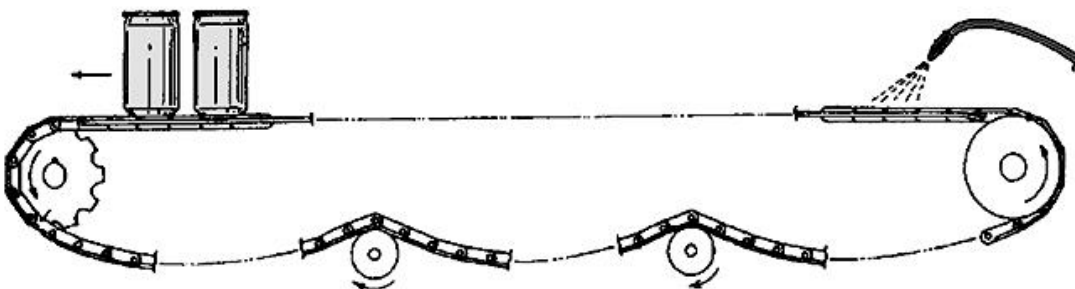

## References

### *Informative references*

Attention is drawn to the following places, which may be of interest for search:

Composition of lubricant	<a href="#">C10M 173/025</a>
Lubricating in general	<a href="#">F16N</a>

## B65G 45/04

for rollers

### Definition statement

*This place covers:*

Illustrative example of subject matter classified in this group:

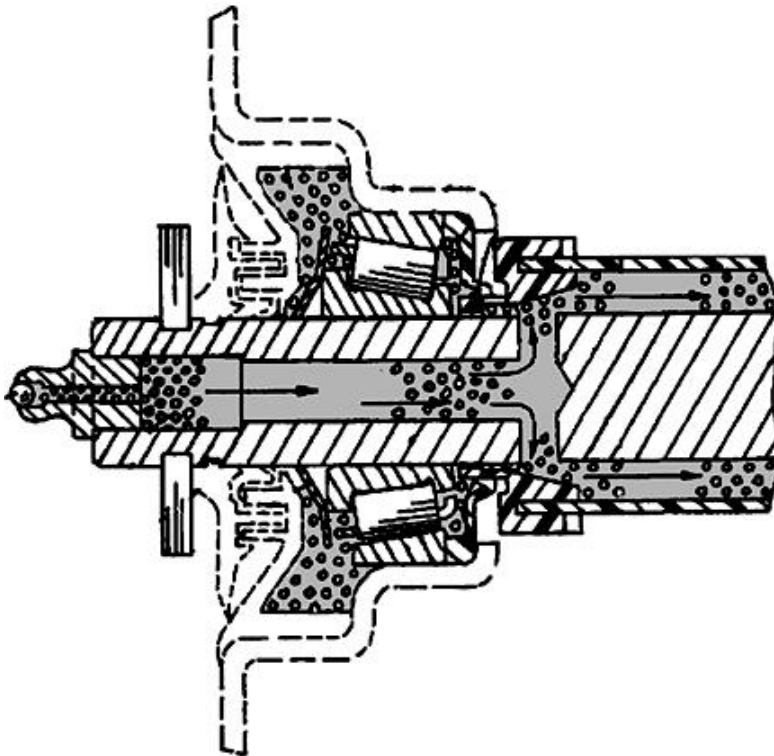

## **B65G 45/06**

**forming belt troughing structure**

### **Definition statement**

*This place covers:*

Illustrative example of subject matter classified in this group:

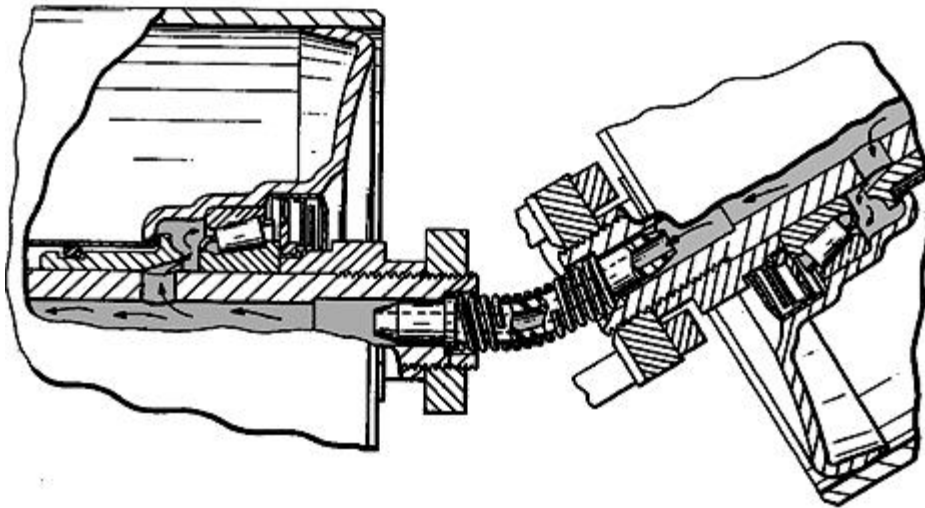

## **B65G 45/08**

**for chains**

### **Definition statement**

*This place covers:*

Only external means for lubricating the chain itself



Illustrative example of subject matter classified in this group:

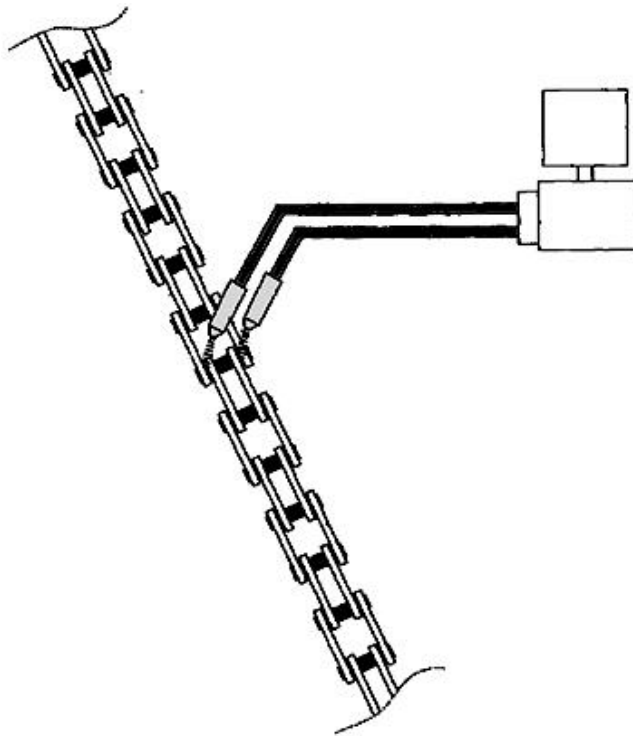

## References

### Informative references

Attention is drawn to the following places, which may be of interest for search:

Self-lubricating chains	<a href="#">B65G 17/38</a>
-------------------------	----------------------------

## B65G 45/10

Cleaning devices (adaptations of roller sleeves for cleaning belts [B65G 39/073](#))

## References

### Limiting references

This place does not cover:

Comprising brushes	<a href="#">B65G 45/18</a>
Comprising fluid applying means	<a href="#">B65G 45/22</a>

### Informative references

Attention is drawn to the following places, which may be of interest for search:

Cleaning escalators	<a href="#">B66B 31/00</a>
---------------------	----------------------------

## B65G 45/105

{comprising vibrating means}

### Definition statement

*This place covers:*

Illustrative example of subject matter classified in this group:

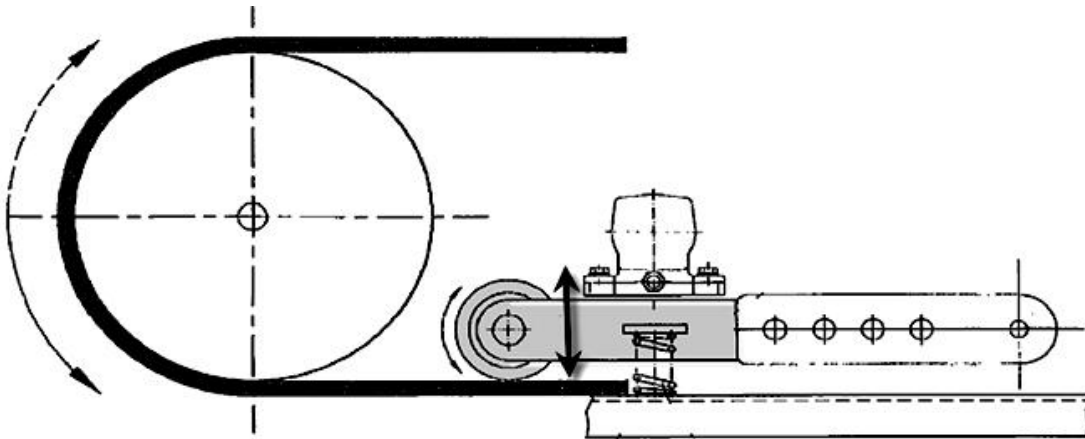

## B65G 45/12

comprising scrapers

### Definition statement

*This place covers:*

Illustrative example of subject matter classified in this group:

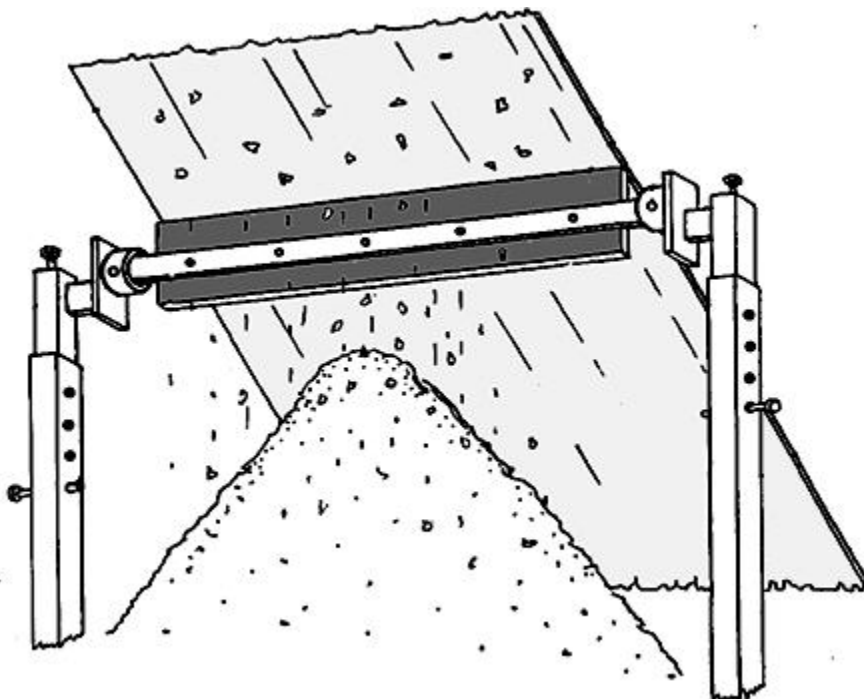

## References

### *Informative references*

Attention is drawn to the following places, which may be of interest for search:

Comprising plural diverse cleaning devices	<a href="#">B65G 45/24</a>
--------------------------------------------	----------------------------

## B65G 45/14

### Moving scrapers

#### Definition statement

*This place covers:*

Illustrative example of subject matter classified in this group:

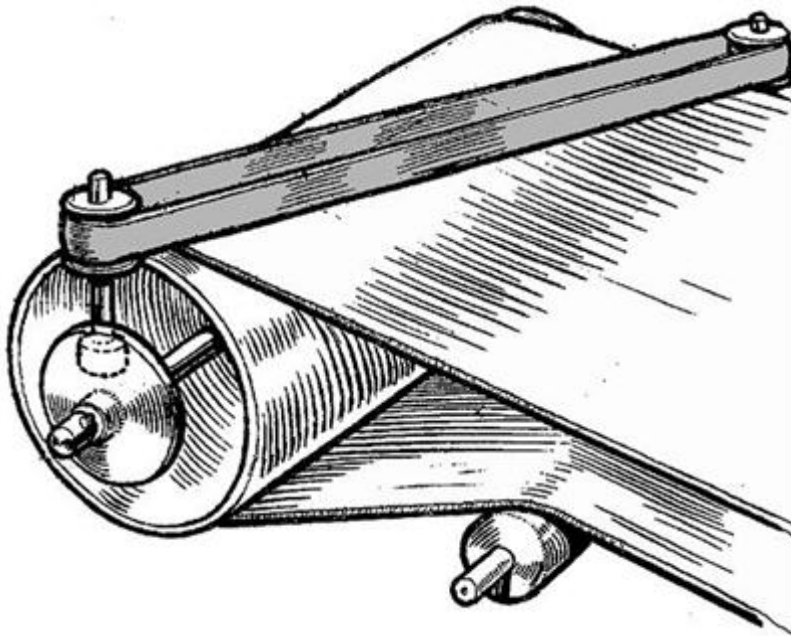

## References

### *Informative references*

Attention is drawn to the following places, which may be of interest for search:

Brushes	<a href="#">B65G 45/18</a>
---------	----------------------------

## B65G 45/16

### with scraper biasing means

#### Definition statement

*This place covers:*

Only with details of the scraper biasing means

Illustrative example of subject matter classified in this group:

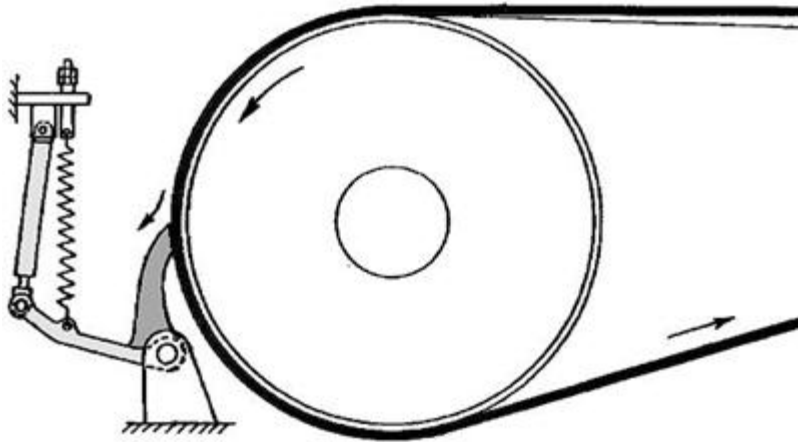

## **B65G 45/18**

comprising brushes

### **Definition statement**

*This place covers:*

Illustrative example of subject matter classified in this group:

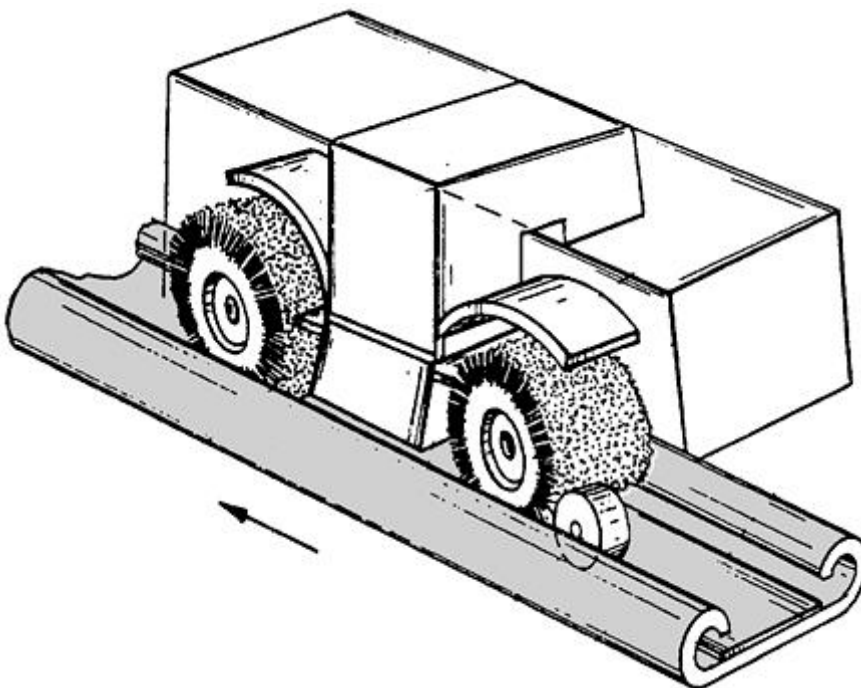

## **References**

### **Informative references**

*Attention is drawn to the following places, which may be of interest for search:*

Comprising plural diverse cleaning device	<a href="#">B65G 45/24</a>
-------------------------------------------	----------------------------

**B65G 45/20**

comprising screws

**Definition statement**

*This place covers:*

Illustrative example of subject matter classified in this group:

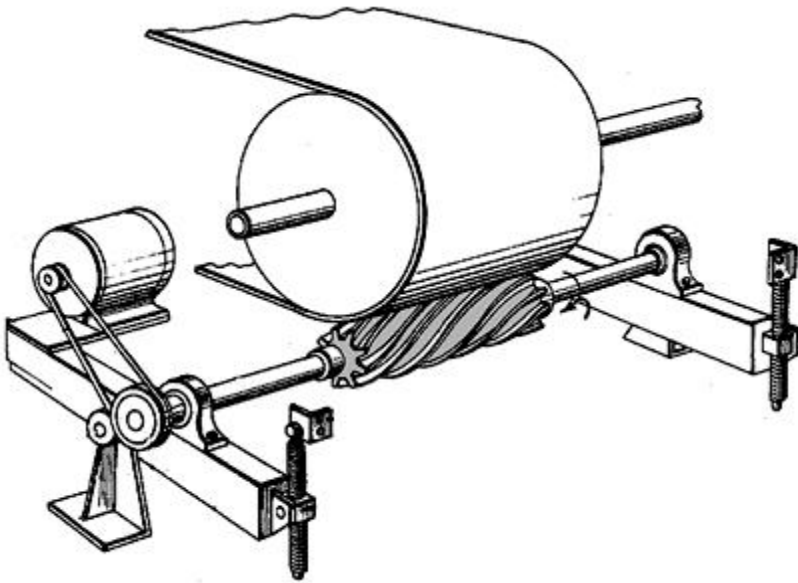
**B65G 45/22**

comprising fluid applying means

**Definition statement**

*This place covers:*

Illustrative example of subject matter classified in this group:

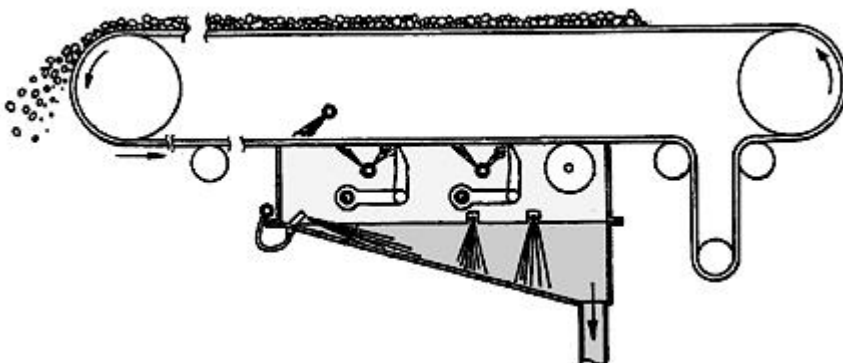
**References****Limiting references**

*This place does not cover:*

Lubricating means	<a href="#">B65G 45/02</a>
-------------------	----------------------------

**Informative references**

Attention is drawn to the following places, which may be of interest for search:

Comprising plural diverse cleaning device	<a href="#">B65G 45/24</a>
-------------------------------------------	----------------------------

**B65G 45/24**

comprising plural diverse cleaning devices

**Definition statement**

*This place covers:*

Illustrative example of subject matter classified in this group:

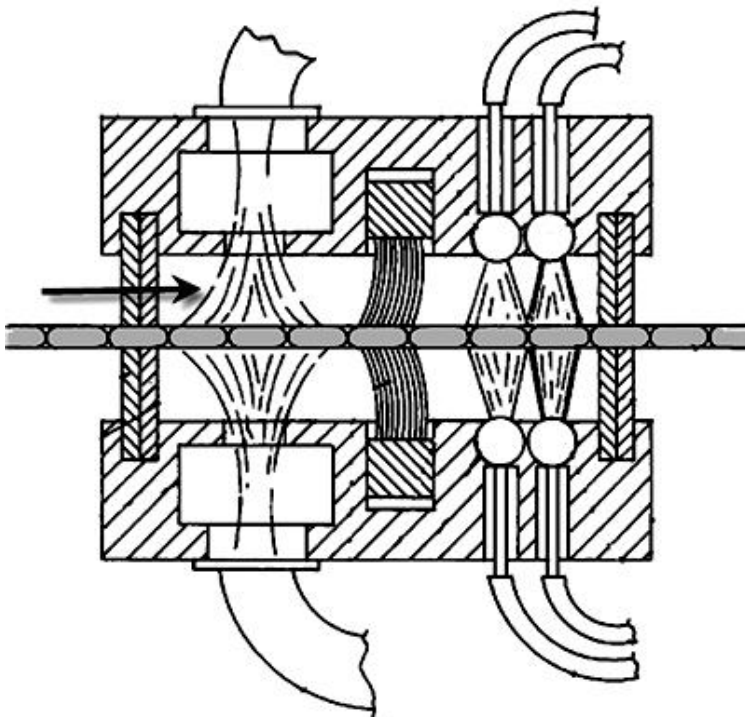

**B65G 45/26****for gathering residue after cleaning****Definition statement***This place covers:*

Illustrative example of subject matter classified in this group:

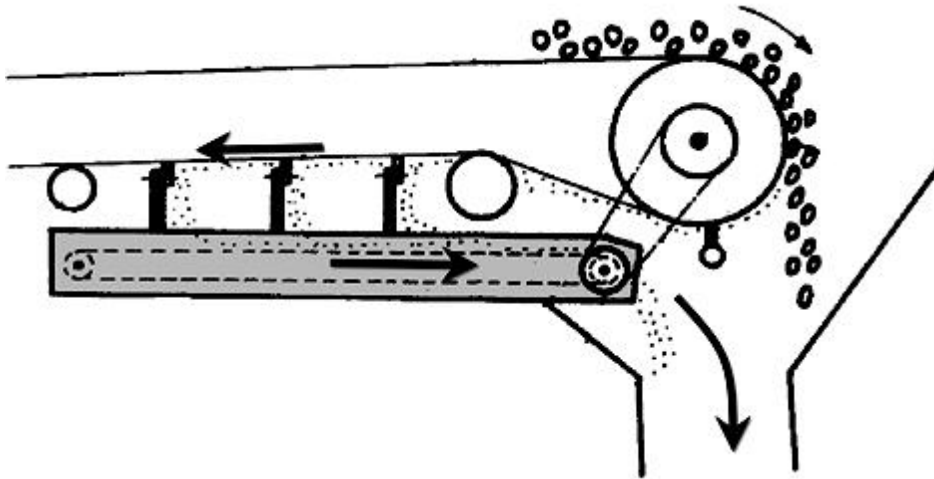
**References****Limiting references***This place does not cover:*

Collecting the cleaning fluid	<a href="#">B65G 45/22</a>
-------------------------------	----------------------------

**Informative references***Attention is drawn to the following places, which may be of interest for search:*

When the moving belt is cleaning the conveyor	<a href="#">B65G 45/14</a>
-----------------------------------------------	----------------------------

**B65G 47/00****Article or material-handling devices associated with conveyors; Methods employing such devices****References****Application-oriented references***Examples of places where the subject matter of this place is covered when specially adapted, used for a particular purpose, or incorporated in a larger system:*

For sorting, e.g. postal	<a href="#">B07C</a>
--------------------------	----------------------



**B65G 47/04**

for feeding articles

**References****Informative references***Attention is drawn to the following places, which may be of interest for search:*

For feeding drugs to packaging devices	<a href="#">B65B</a>
----------------------------------------	----------------------

**B65G 47/06**from a single group of articles arranged in orderly pattern, e.g. workpieces in magazines (de-stacking devices [B65G 59/00](#))**Definition statement***This place covers:*

Magazine in combination with feeding device

Illustrative example of subject matter classified in this group:

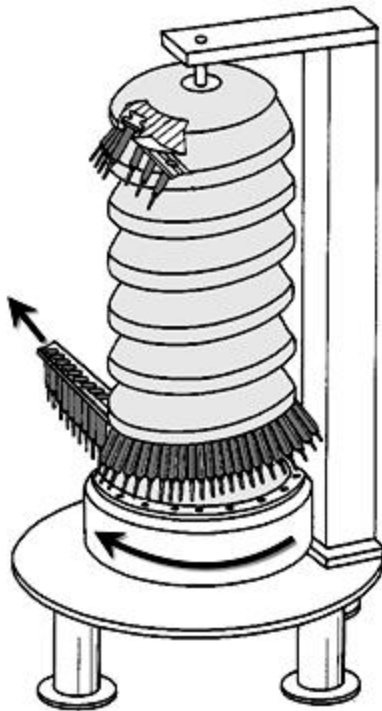
**References****Limiting references***This place does not cover:*

De-stacking devices	<a href="#">B65G 59/00</a>
---------------------	----------------------------



**Informative references**

Attention is drawn to the following places, which may be of interest for search:

For feeding screws or nails to assembling machines	<a href="#">B65G 47/5104</a> , <a href="#">B23P</a>
Picking-up flat workpieces	<a href="#">B65H</a>

**Special rules of classification**

Only magazine in combination with feeding devices

**B65G 47/08**

spacing or grouping the articles during feeding (during transit by conveyor [B65G 47/28](#))

**Definition statement**

This place covers:

Illustrative example of subject matter classified in this group:

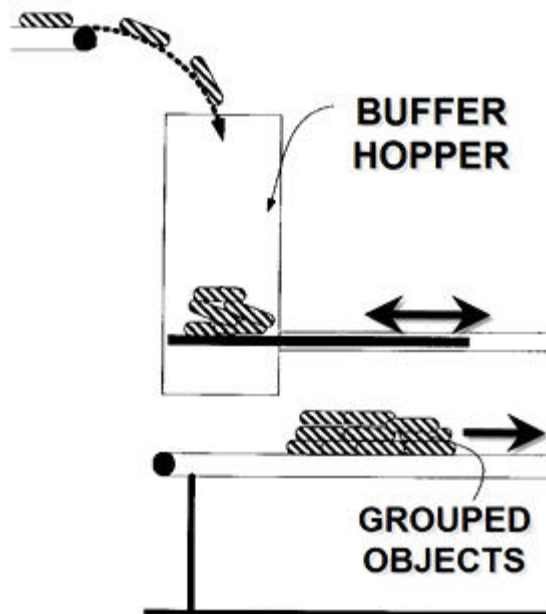
**References****Limiting references**

This place does not cover:

During transit by conveyor	<a href="#">B65G 47/28</a>
----------------------------	----------------------------

**Informative references**

Attention is drawn to the following places, which may be of interest for search:

Accumulating articles	<a href="#">B65G 47/261</a>
-----------------------	-----------------------------

**B65G 47/082****{grouping articles in rows}****Definition statement***This place covers:*

Illustrative example of subject matter classified in this group:

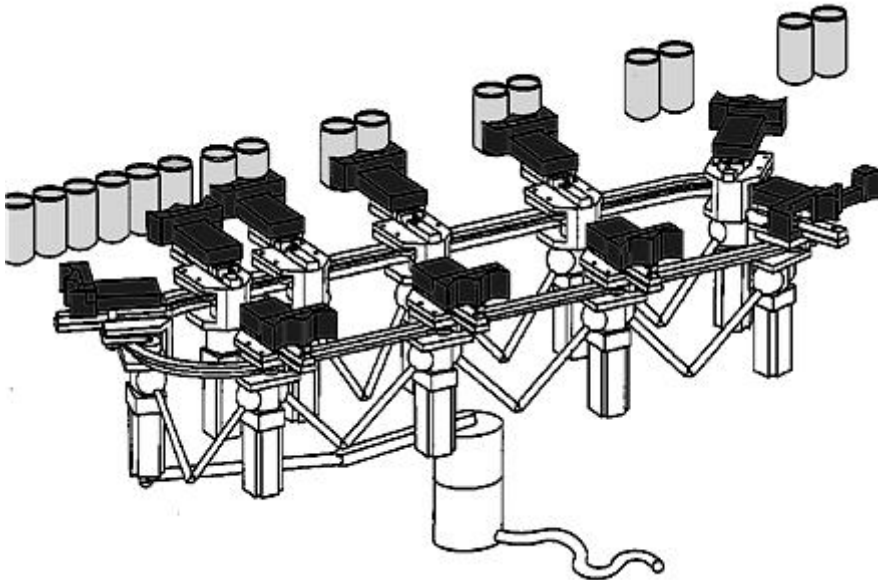
**References****Informative references***Attention is drawn to the following places, which may be of interest for search:*

By varying the relative speeds of the conveyors forming the series	<a href="#">B65G 47/31</a>
By relative displacement between conveyor and conveyor in- or output means	<a href="#">B65G 47/5127</a>
Arranging, assembling, feeding, or orientating the bottles prior to introduction into, or after removal from, containers	<a href="#">B65B 21/04</a>
Forming groups of bottles	<a href="#">B65B 21/06</a>

**B65G 47/084****{grouping articles in a predetermined 2-dimensional pattern}****Definition statement***This place covers:*

Illustrative example of subject matter classified in this group:

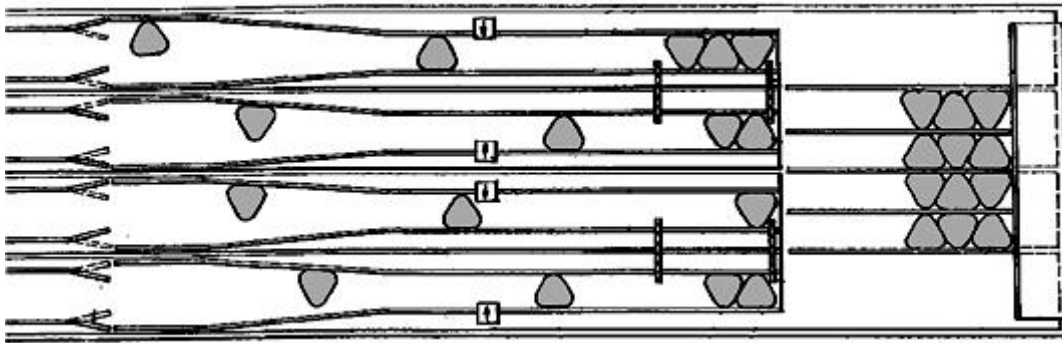
**References****Informative references***Attention is drawn to the following places, which may be of interest for search:*

Comprising individual load carriers which are movably mounted	<a href="#">B65G 17/005</a>
By varying the speeds	<a href="#">B65G 47/31</a>
Devices having endless travelling belts or chains equipped with article-engaging elements	<a href="#">B65G 47/841</a>
The layers being transferred as a whole	<a href="#">B65G 57/24</a>

**B65G 47/086****{cubiform articles}****Definition statement***This place covers:*

Illustrative example of subject matter classified in this group:

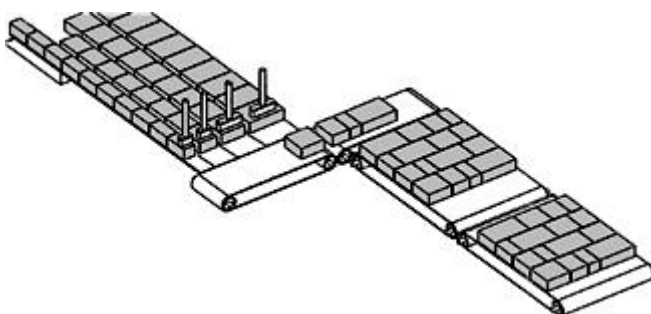

## References

### Informative references

Attention is drawn to the following places, which may be of interest for search:

Comprising individual load carriers which are movably mounted	<a href="#">B65G 17/005</a>
By varying the speeds	<a href="#">B65G 47/31</a>
Devices having endless travelling belts or chains equipped with article-engaging elements	<a href="#">B65G 47/841</a>
The layers being transferred as a whole	<a href="#">B65G 57/24</a>

## B65G 47/088

{cylindrical articles}

### Definition statement

This place covers:

Illustrative example of subject matter classified in this group:

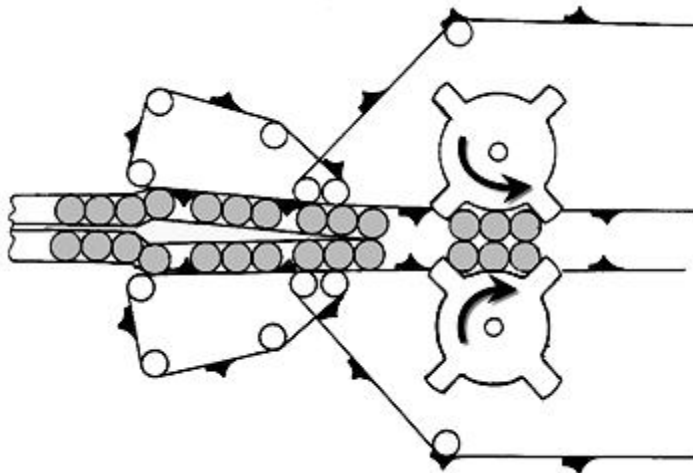

## References

### Informative references

Attention is drawn to the following places, which may be of interest for search:

Comprising individual load carriers which are movably mounted	<a href="#">B65G 17/005</a>
By varying the speeds	<a href="#">B65G 47/31</a>
Devices having endless travelling belts or chains equipped with article-engaging elements	<a href="#">B65G 47/841</a>
The layers being transferred as a whole	<a href="#">B65G 57/24</a>

**B65G 47/1407**

{the articles being fed from a container, e.g. a bowl}

**Definition statement**

*This place covers:*

Illustrative example of subject matter classified in this group:

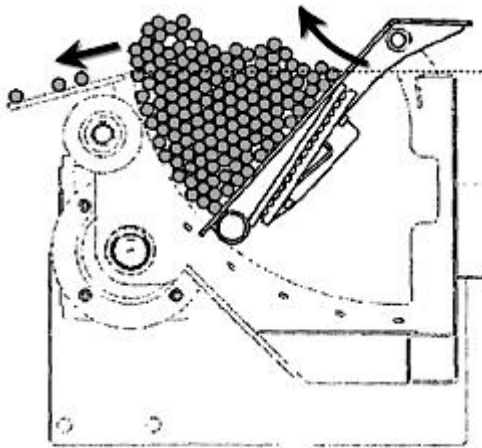
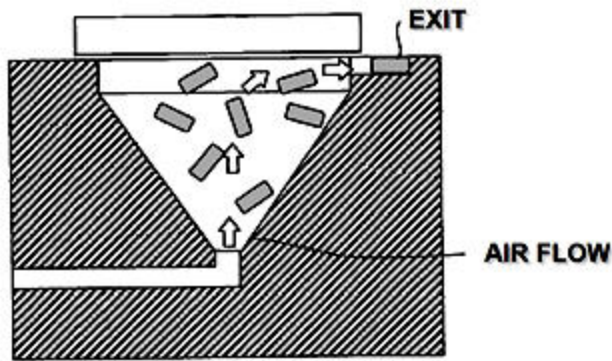
**References****Informative references**

*Attention is drawn to the following places, which may be of interest for search:*

For bars or long objects	<a href="#">B21B 39/002</a>
Feeding articles, e.g. screws, springs, from a container to machines	<a href="#">B23P 19/001</a>
The walls being deformable	<a href="#">B65D 88/62</a>

## B65G 47/1414

{by means of movement of at least the whole wall of the container}

### Definition statement

*This place covers:*

Illustrative example of subject matter classified in this group:

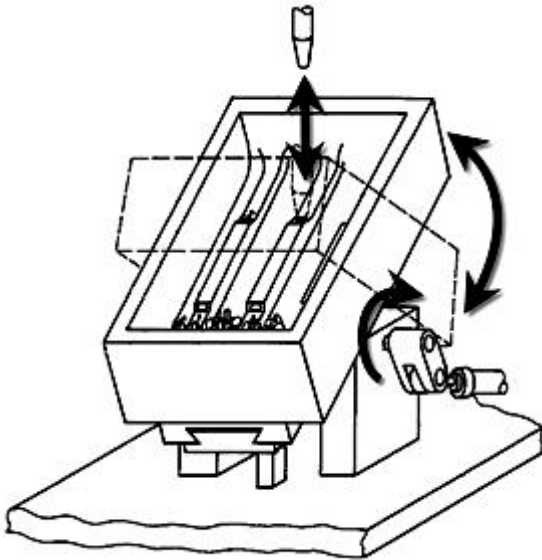

## B65G 47/1421

{Vibratory movement}

### Definition statement

*This place covers:*

Illustrative example of subject matter classified in this group:

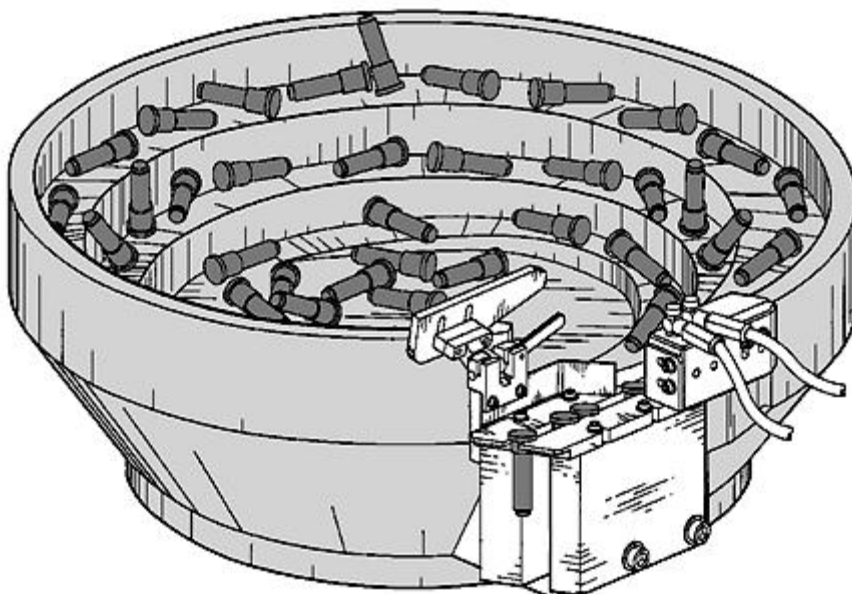

## B65G 47/1428

{rotating movement}

### Definition statement

*This place covers:*

Illustrative example of subject matter classified in this group:

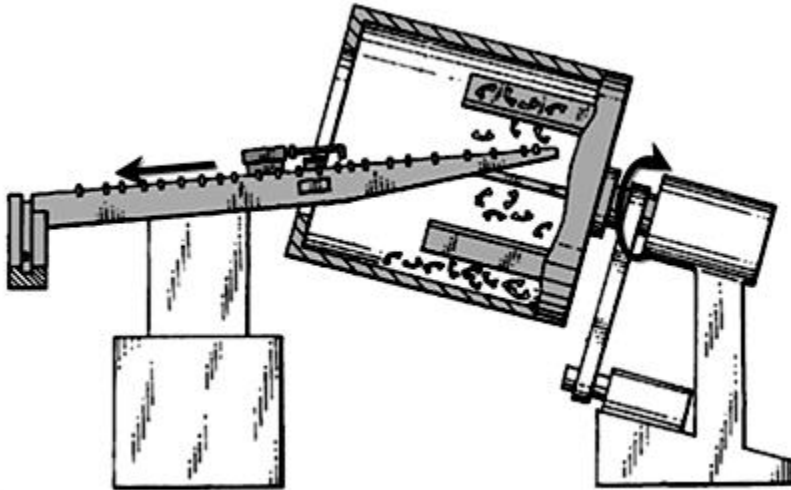

## B65G 47/1435

{using the centrifugal effect to arrange or orientate the articles}

### Definition statement

*This place covers:*

Illustrative example of subject matter classified in this group:

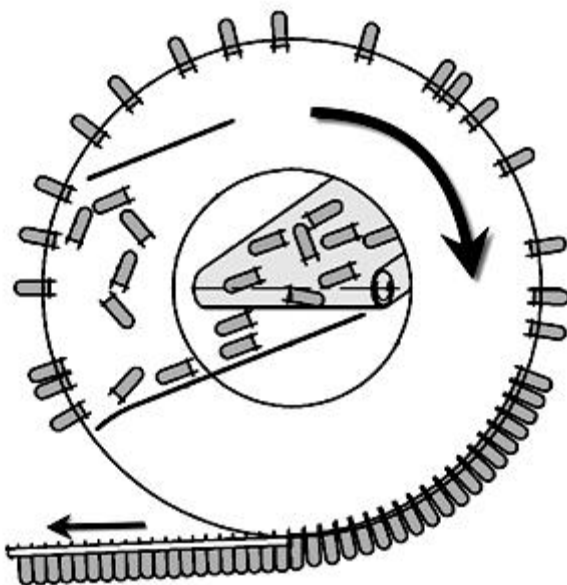



## B65G 47/145

{Jigging or reciprocating movement}

### Definition statement

*This place covers:*

Illustrative example of subject matter classified in this group:

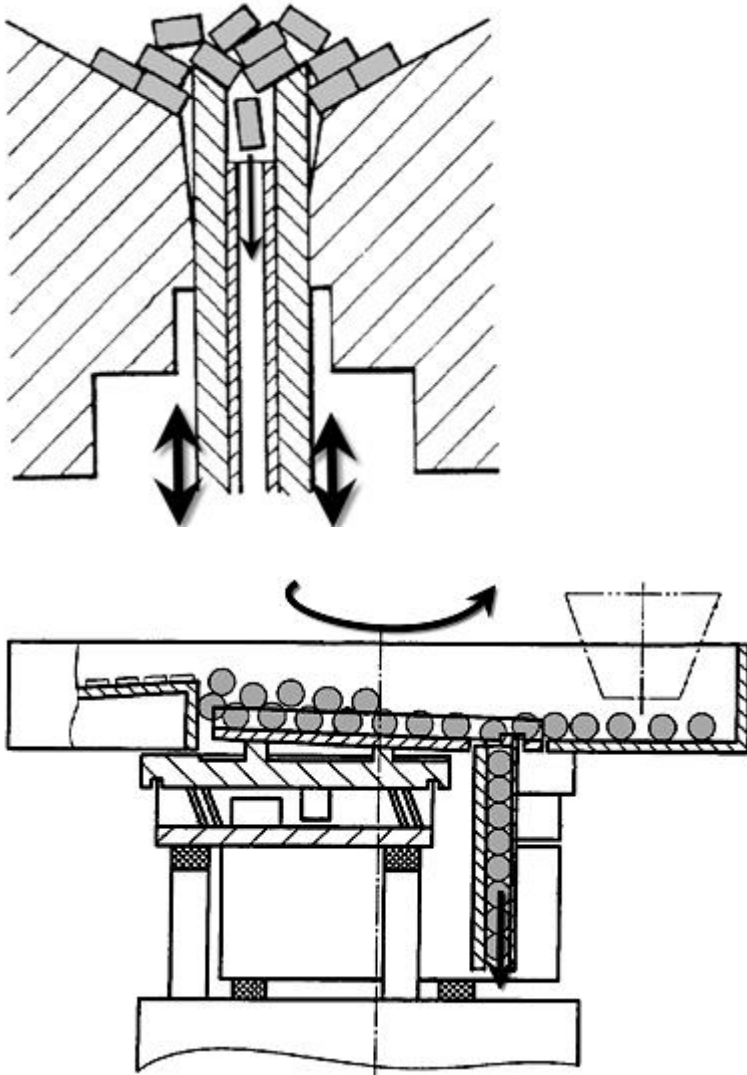



## B65G 47/1457

{Rotating movement in the plane of the rotating part}

### Definition statement

*This place covers:*

Illustrative example of subject matter classified in this group:

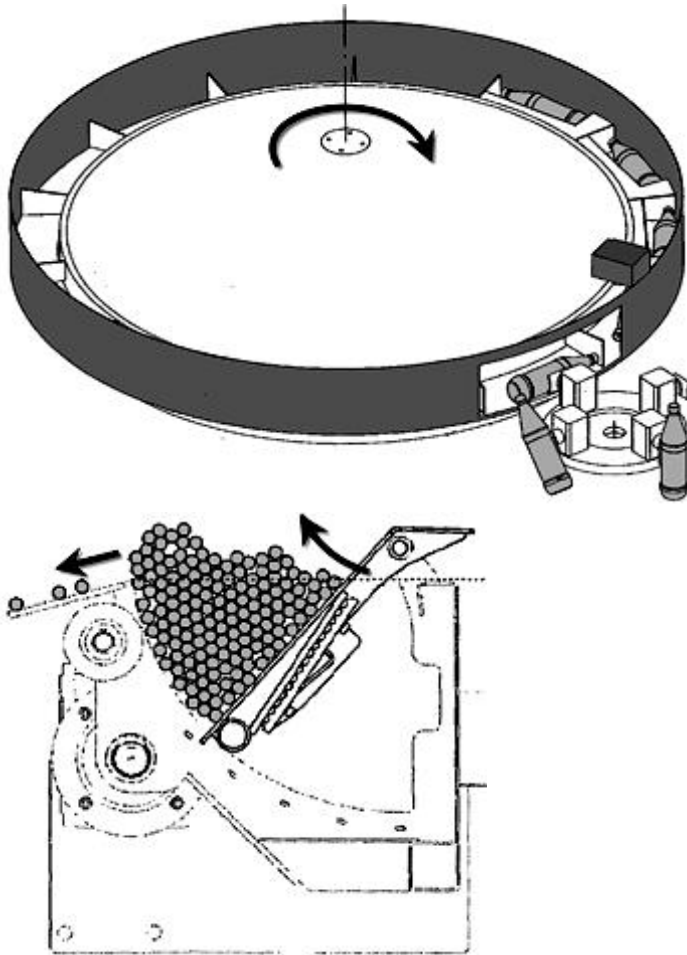

## **B65G 47/1464**

**{using the centrifugal effect to arrange or orientate the articles}**

### **Definition statement**

*This place covers:*

Illustrative example of subject matter classified in this group:

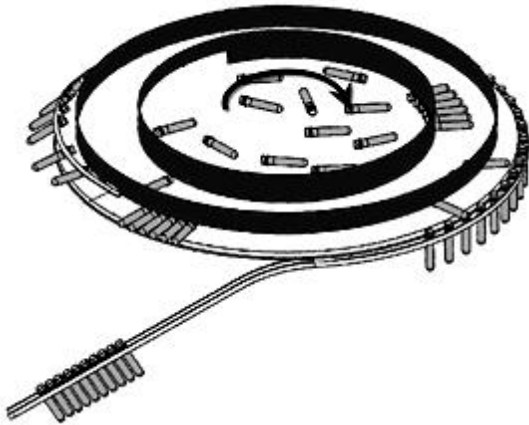

## **B65G 47/1471**

**{Movement in one direction, substantially outwards}**

### **Definition statement**

*This place covers:*

Only a plurality of articles moving out simultaneously

Illustrative example of subject matter classified in this group:

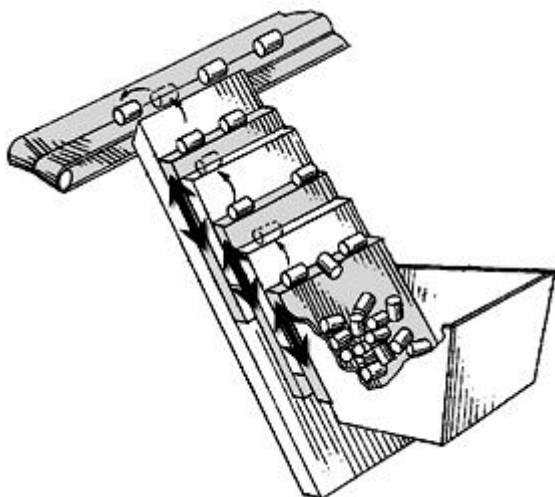

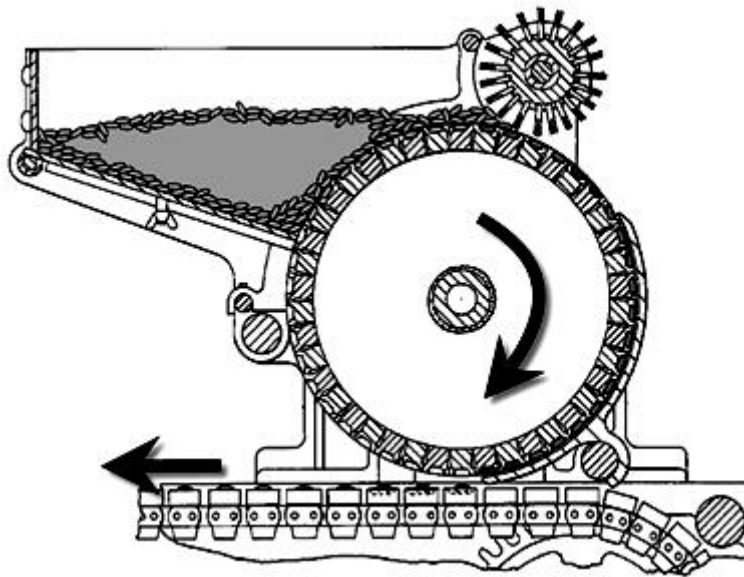

## References

### Limiting references

*This place does not cover:*

By means of pick-up devices, the container remaining immobile	<a href="#">B65G 47/1478</a>
Only a single article picked up at once	<a href="#">B65G 47/1478</a>
Using suction or magnetic forces	<a href="#">B65G 47/1485</a>

### Informative references

*Attention is drawn to the following places, which may be of interest for search:*

Having impellers	<a href="#">B65G 25/08</a>
Using pocketed conveyors	<a href="#">B65B 35/08</a>
Caps	<a href="#">B67B 3/06</a>

## B65G 47/1478

**{by means of pick-up devices, the container remaining immobile}**

### Definition statement

*This place covers:*

Only a single article picked up at once

Illustrative example of subject matter classified in this group:

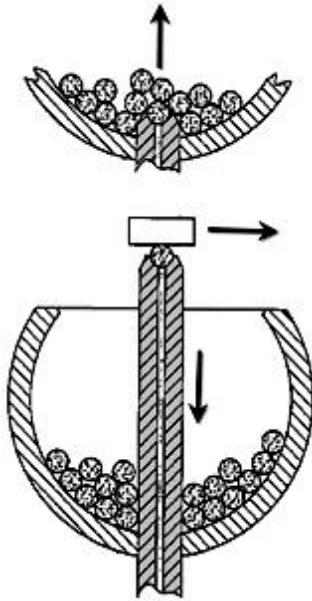

**References**

**Limiting references**

*This place does not cover:*

Movement in one direction, substantially downwards	<a href="#">B65G 47/1471</a>
Only a plurality of articles moving out simultaneously	<a href="#">B65G 47/1471</a>

**B65G 47/1485**

{using suction or magnetic forces}

**Definition statement**

*This place covers:*

Illustrative example of subject matter classified in this group:

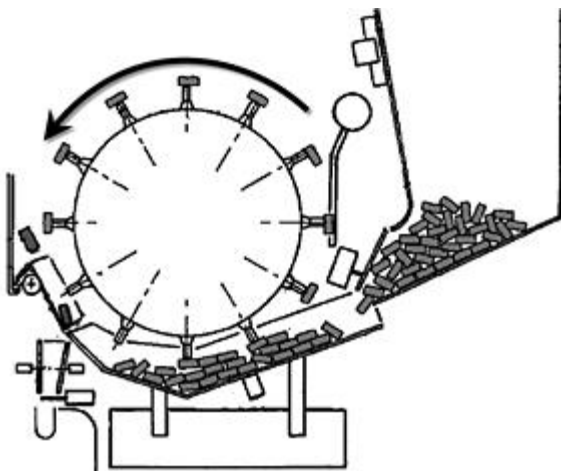

## B65G 47/1492

{the articles being fed from a feeding conveyor}

### Definition statement

*This place covers:*

Illustrative example of subject matter classified in this group:

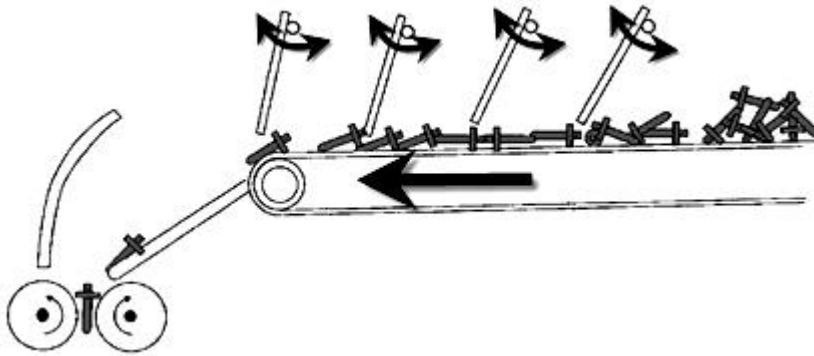

## B65G 47/18

Arrangements or applications of hoppers or chutes

### Definition statement

*This place covers:*

Illustrative example of subject matter classified in this group:

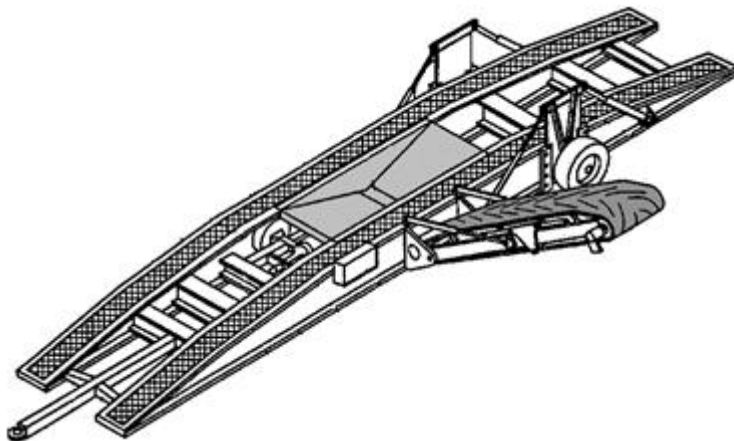

**B65G 47/19**

having means for controlling material flow, e.g. to prevent overloading

**Definition statement**

*This place covers:*

Illustrative example of subject matter classified in this group:

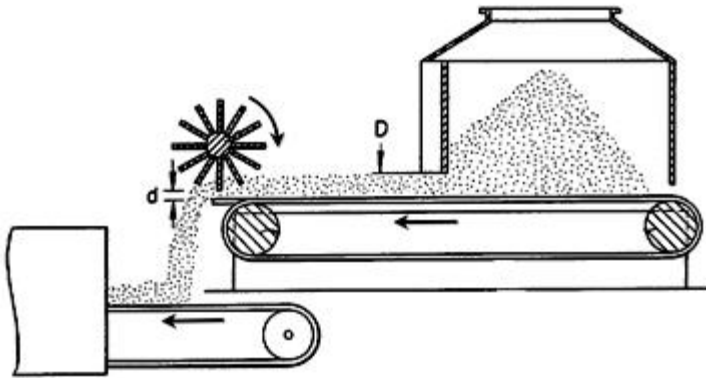
**References****Informative references**

*Attention is drawn to the following places, which may be of interest for search:*

Emptying using belt or chain conveyors	<a href="#">B65G 65/42</a>
Controlling feed or discharge by weighing a continuous stream of material	<a href="#">G01G 11/08</a>

## **B65G 47/20**

**the hoppers or chutes being movable**

### **Definition statement**

*This place covers:*

Illustrative example of subject matter classified in this group:

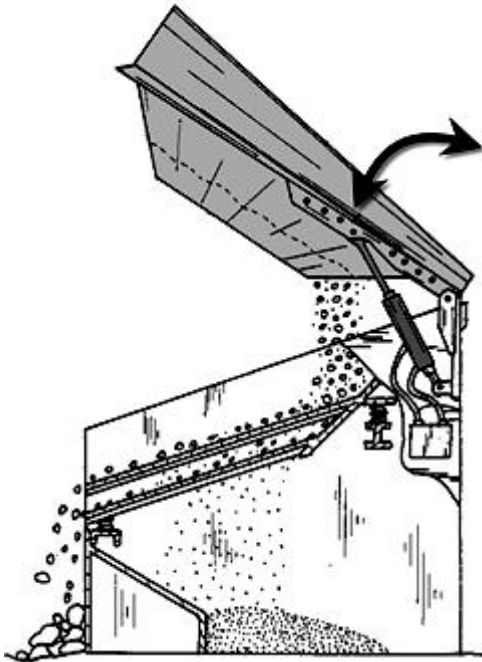

## **B65G 47/22**

**Devices influencing the relative position or the attitude of articles during transit by conveyors (during feeding [B65G 47/14](#))**

### **Definition statement**

*This place covers:*

Only for arranging (NOT orientating), e.g. aligning "disordered" articles on the conveyor

Illustrative example of subject matter classified in this group:

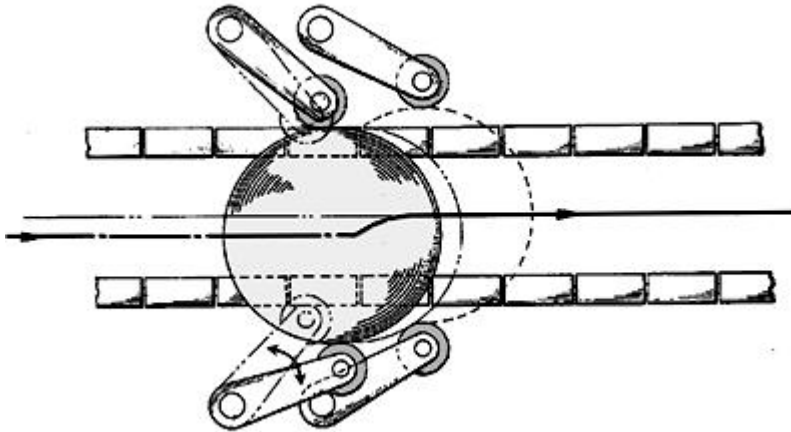

## References

### Informative references

Attention is drawn to the following places, which may be of interest for search:

For changing the relative position of the articles	<a href="#">B65G 47/26</a> - <a href="#">B65G 47/31</a>
----------------------------------------------------	---------------------------------------------------------

## Special rules of classification

Difference between aligning and orientating:

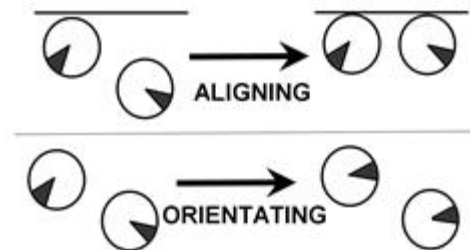

## B65G 47/24

### orientating the articles

#### Definition statement

*This place covers:*

The articles have various orientations before the orientating process



Illustrative example of subject matter classified in this group:

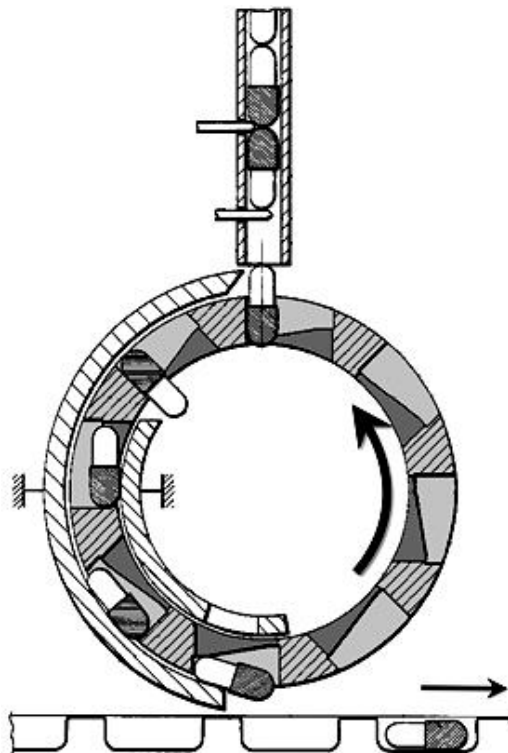
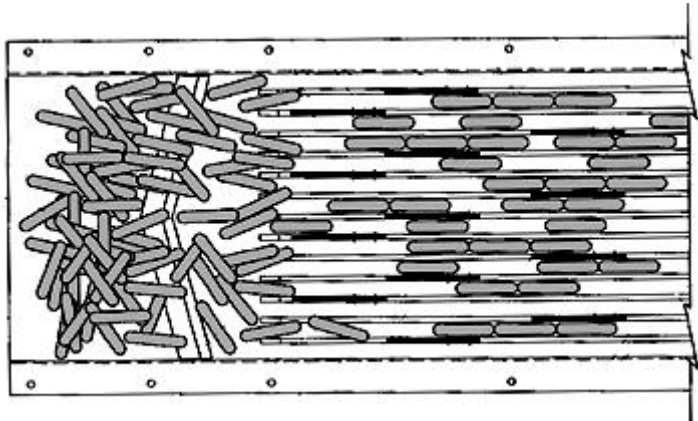

### **B65G 47/24**

**by turning them about an axis substantially perpendicular to the conveying plane**

#### **Definition statement**

*This place covers:*

The articles have the same orientation before the orientating process

Illustrative example of subject matter classified in this group:

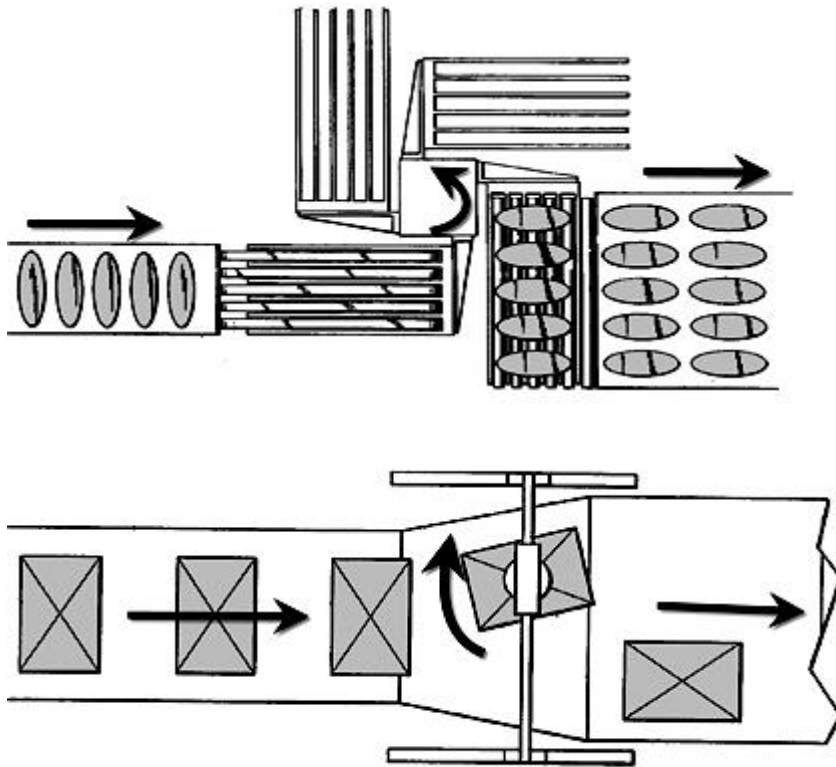

## References

### Informative references

Attention is drawn to the following places, which may be of interest for search:

Cubiform articles	<a href="#">B65G 47/086</a>
-------------------	-----------------------------

## B65G 47/2445

{by means of at least two co-operating endless conveying elements}

### Definition statement

This place covers:

Illustrative example of subject matter classified in this group:

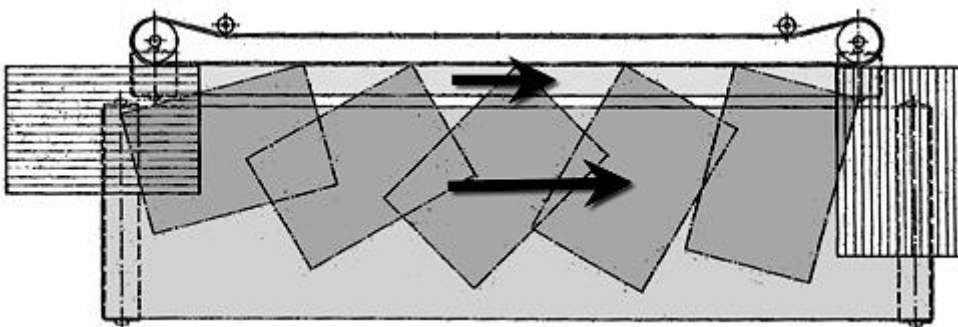

## References

### Informative references

Attention is drawn to the following places, which may be of interest for search:

The load being conveyed between the belts	<a href="#">B65G 15/14</a>
-------------------------------------------	----------------------------

## B65G 47/248

by turning over or inverting them ([B65G 47/244](#) takes precedence)

### Definition statement

*This place covers:*

Only when (1) the article does NOT remain on the conveyor onto which is fed, (2) a separate conveyor or (3) an intersection between conveyors - does the function of turning

Illustrative example of subject matter classified in this group:

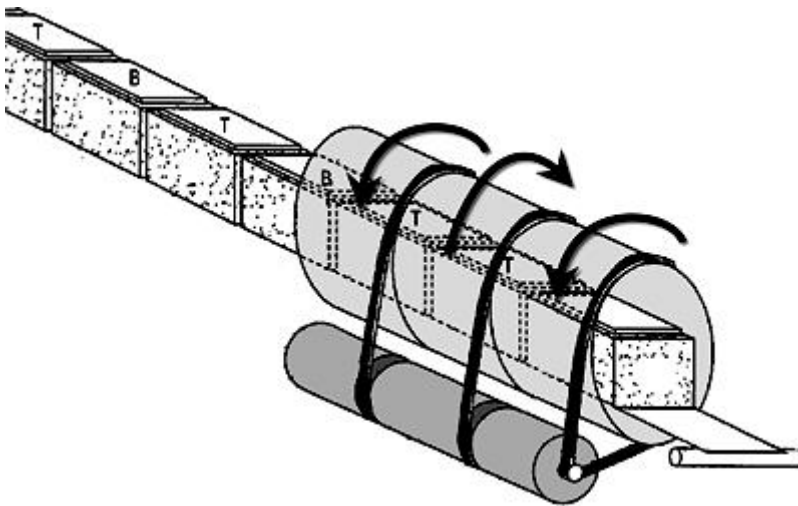
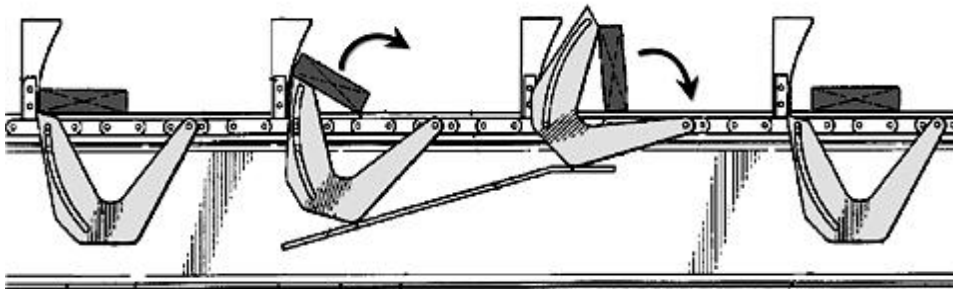

## References

### Limiting references

*This place does not cover:*

About an axis substantially perpendicular to the conveying direction	<a href="#">B65G 47/252</a>
----------------------------------------------------------------------	-----------------------------

**Informative references**

Attention is drawn to the following places, which may be of interest for search:

By turning over or inverting them during transit	<a href="#">B65G 47/244</a>
--------------------------------------------------	-----------------------------

**B65G 47/252**

about an axis substantially perpendicular to the conveying direction

**Definition statement**

*This place covers:*

Illustrative example of subject matter classified in this group:

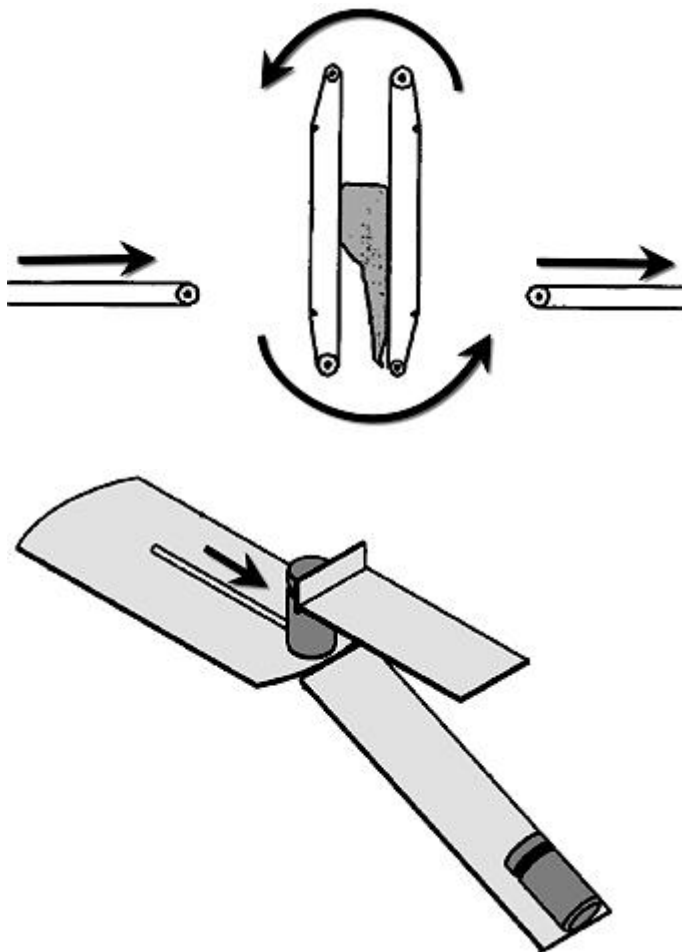

**B65G 47/256**

removing incorrectly orientated articles

**Definition statement**

*This place covers:*

Illustrative example of subject matter classified in this group:

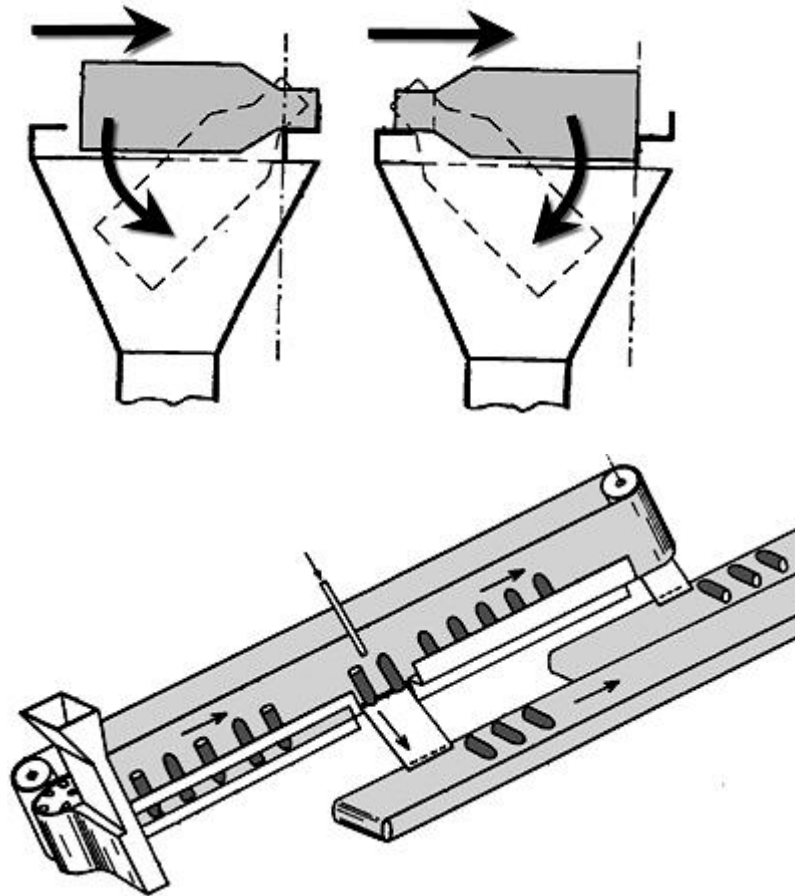
**B65G 47/26**

arranging the articles, e.g. varying spacing between individual articles

**Definition statement**

*This place covers:*

Illustrative example of subject matter classified in this group:

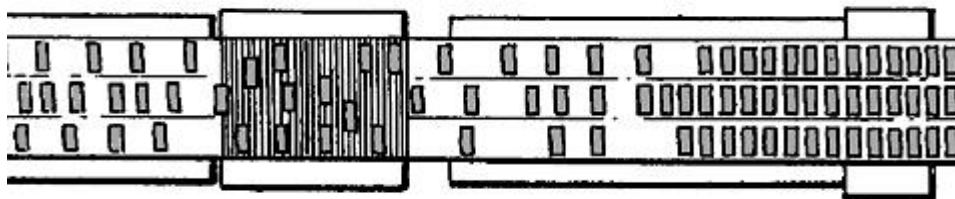

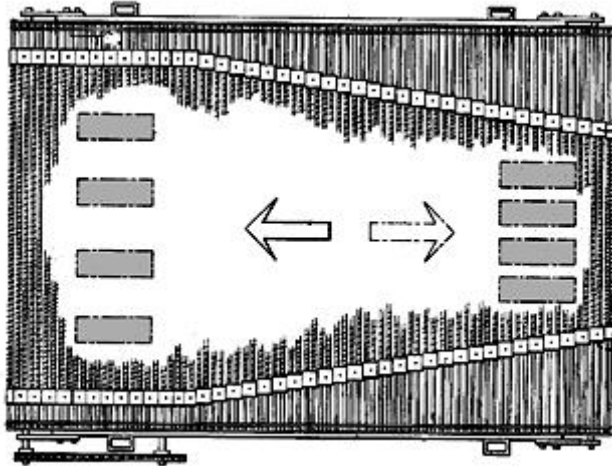
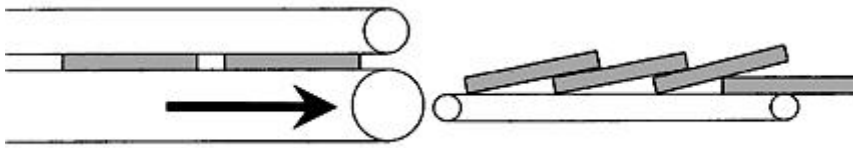

## References

### Informative references

Attention is drawn to the following places, which may be of interest for search:

By varying the relative speeds of the conveyors forming the series	<a href="#">B65G 47/31</a>
Stacking or de-stacking	<a href="#">B65G 57/00</a> , <a href="#">B65G 59/00</a> , <a href="#">B65G 61/00</a>
During transit	<a href="#">B65G 57/32</a> , <a href="#">B65G 59/12</a>
Counting articles on a conveyor	<a href="#">G06M 7/00</a>

## B65G 47/261

{Accumulating articles}

### Definition statement

This place covers:

Illustrative example of subject matter classified in this group:

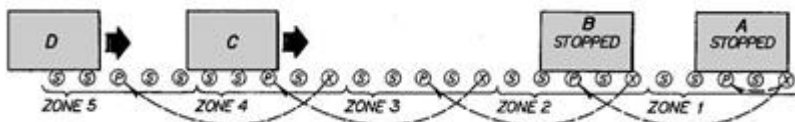

## References

### Informative references

Attention is drawn to the following places, which may be of interest for search:

Stops	<a href="#">B65G 47/88</a>
-------	----------------------------



Control of drive	<a href="#">B65G 47/88</a>
------------------	----------------------------

## B65G 47/263

{the conveyor drive is taken from a longitudinally extending shaft}

### Definition statement

*This place covers:*

Illustrative example of subject matter classified in this group:

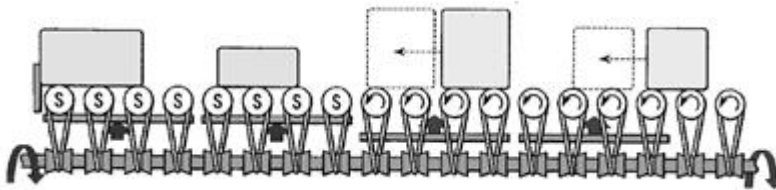

### References

#### Informative references

Attention is drawn to the following places, which may be of interest for search:

Free-wheel gearing roller conveyor	<a href="#">B65G 13/073</a>
------------------------------------	-----------------------------

## B65G 47/265

{with one or more load advancing units travelling along the entire length of the accumulation line}

### Definition statement

*This place covers:*

Illustrative example of subject matter classified in this group:

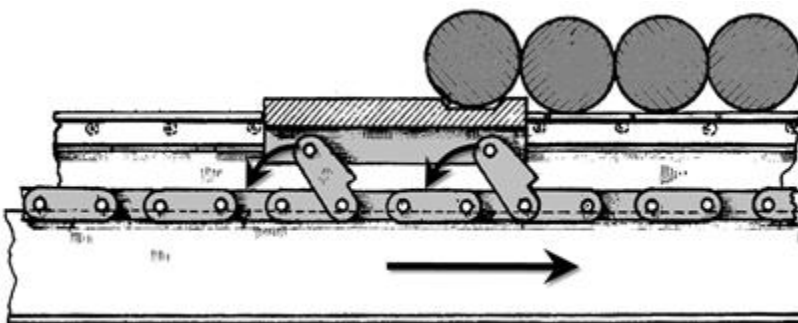

### References

#### Informative references

Attention is drawn to the following places, which may be of interest for search:

Conveyors comprising a cyclically-moving	<a href="#">B65G 25/00</a>
------------------------------------------	----------------------------

**B65G 47/266****{by means of a series of pivotable stop elements}****Definition statement***This place covers:*

Illustrative example of subject matter classified in this group:

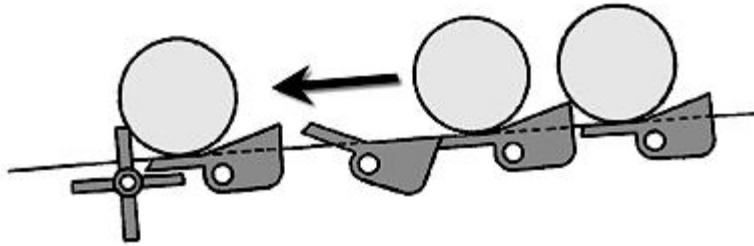
**References****Informative references***Attention is drawn to the following places, which may be of interest for search:*

Stop elements	<a href="#">B65G 47/8807</a>
---------------	------------------------------

**B65G 47/268****{by means of belt or chain conveyor}****Definition statement***This place covers:*

When the belt and the chain is the driving element

Illustrative example of subject matter classified in this group:

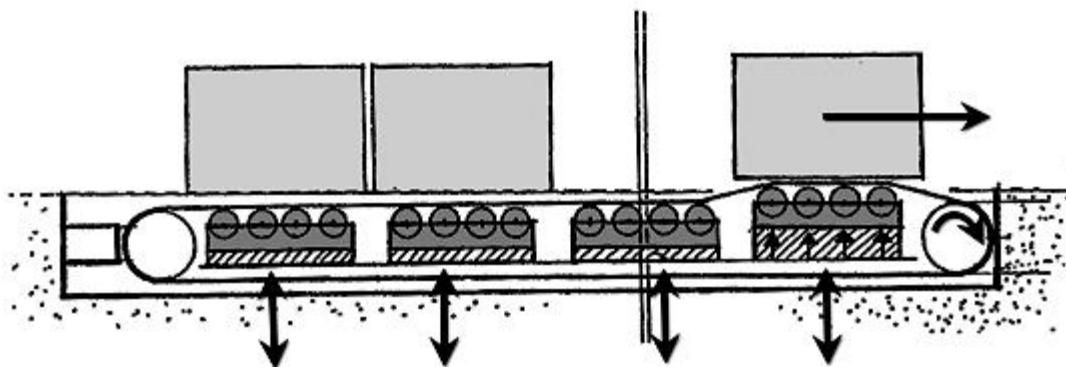
**References****Informative references***Attention is drawn to the following places, which may be of interest for search:*

A belt or a chain can be the supporting element	<a href="#">B65G 47/261</a>
-------------------------------------------------	-----------------------------



**B65G 47/28**

during transit by a single conveyor

**Definition statement**

*This place covers:*

Singulating articles

Illustrative example of subject matter classified in this group:

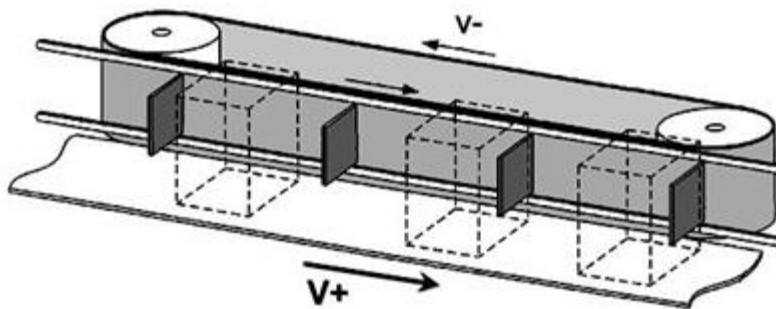
**References****Informative references**

Attention is drawn to the following places, which may be of interest for search:

Comprising a series of rollers which are moved	<a href="#">B65G 17/24</a>
------------------------------------------------	----------------------------

**B65G 47/29**

by temporarily stopping movement {(stopping elements [B65G 47/88](#))}

**Definition statement**

*This place covers:*

With moving elements to release the articles

Illustrative example of subject matter classified in this group:

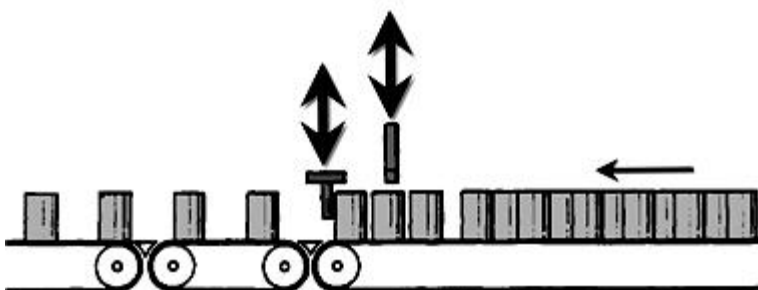

## References

### Informative references

Attention is drawn to the following places, which may be of interest for search:

Arranging the articles	<a href="#">B65G 47/26</a>
------------------------	----------------------------

## B65G 47/295

{by means of at least two stopping elements}

### Definition statement

*This place covers:*

Stopping elements with time controlled release

Illustrative example of subject matter classified in this group:

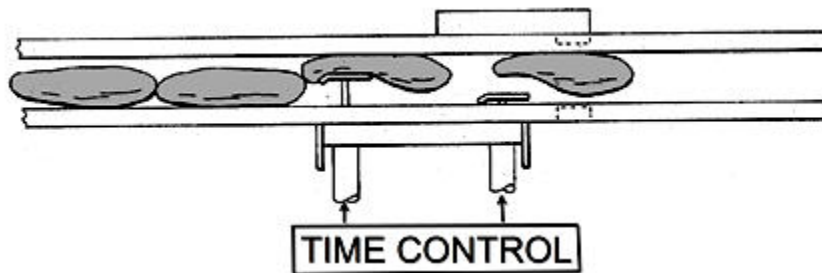

## References

### Informative references

Attention is drawn to the following places, which may be of interest for search:

Stops acting asynchronously	<a href="#">B65G 47/8884</a>
-----------------------------	------------------------------

## B65G 47/30

during transit by a series of conveyors

### Definition statement

*This place covers:*

Illustrative example of subject matter classified in this group:

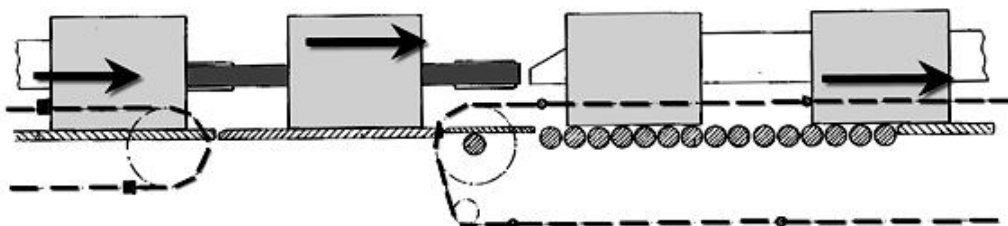

**B65G 47/31**

by varying the relative speeds of the conveyors forming the series

**Definition statement**

*This place covers:*

Illustrative example of subject matter classified in this group:

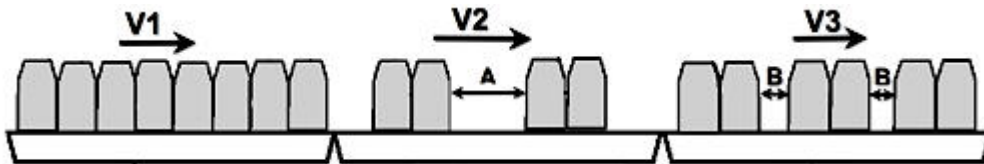
**References****Informative references**

Attention is drawn to the following places, which may be of interest for search:

Displacing the intersection between two conveyors having different speeds	<a href="#">B65G 21/14</a>
Control	<a href="#">B65G 43/08</a>
Sequence control of conveyors operating in combination	<a href="#">B65G 43/10</a>

**B65G 47/32**

Applications of transfer devices {(such devices per se [B65G 47/74](#))}

**Definition statement**

*This place covers:*

Illustrative example of subject matter classified in this group:

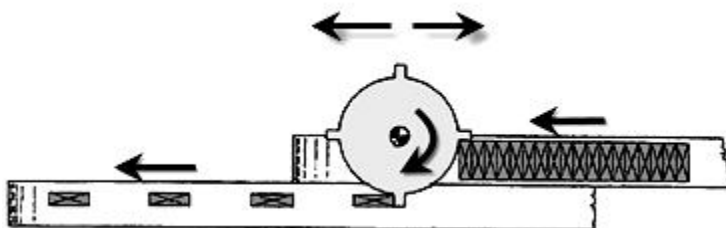

**B65G 47/34**

**Devices for discharging articles or materials from conveyor**  
([B65G 47/256](#) takes precedence)

**Definition statement**

*This place covers:*

Illustrative example of subject matter classified in this group:

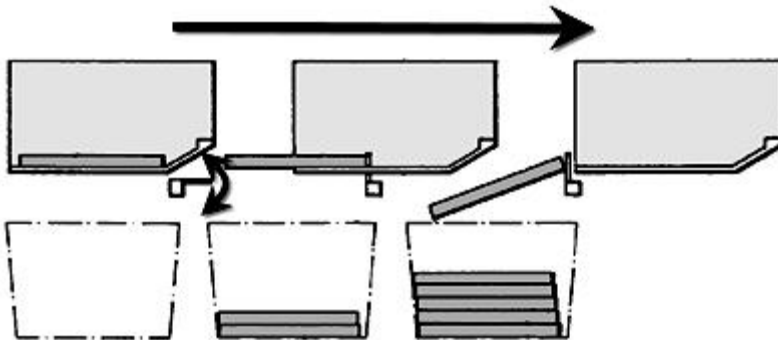
**References****Limiting references**

*This place does not cover:*

Removing incorrectly orientated articles	<a href="#">B65G 47/256</a>
------------------------------------------	-----------------------------

**Informative references**

*Attention is drawn to the following places, which may be of interest for search:*

Comprising a series of rollers which are moved	<a href="#">B65G 17/24</a>
Sorting in general	<a href="#">B07</a>

**B65G 47/36**

**by detaching suspended articles**

**References****Informative references**

*Attention is drawn to the following places, which may be of interest for search:*

For articles	<a href="#">B65G 47/61</a>
--------------	----------------------------

**B65G 47/38**

by dumping, tripping, or releasing load carriers (by flexing or tilting travelling structures [B65G 47/94](#))

**Definition statement**

*This place covers:*

Illustrative example of subject matter classified in this group:

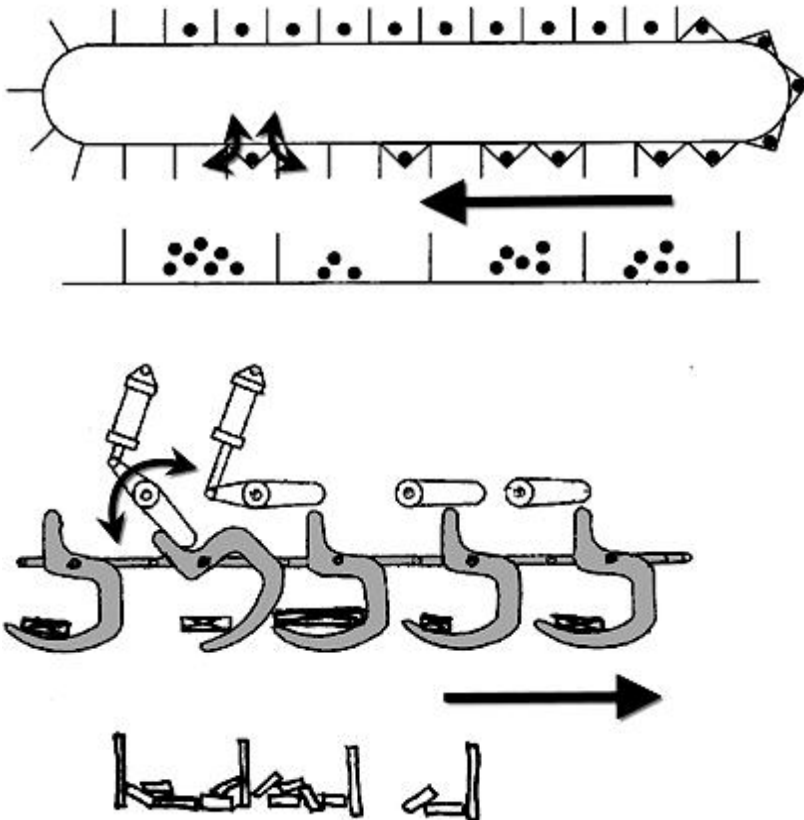
**References****Limiting references**

*This place does not cover:*

By tilting conveyor buckets	<a href="#">B65G 47/40</a>
-----------------------------	----------------------------

**Informative references**

*Attention is drawn to the following places, which may be of interest for search:*

Basculating sideways	<a href="#">B65G 47/962</a>
----------------------	-----------------------------

**B65G 47/40****by tilting conveyor buckets****Definition statement**

*This place covers:*

Illustrative example of subject matter classified in this group:

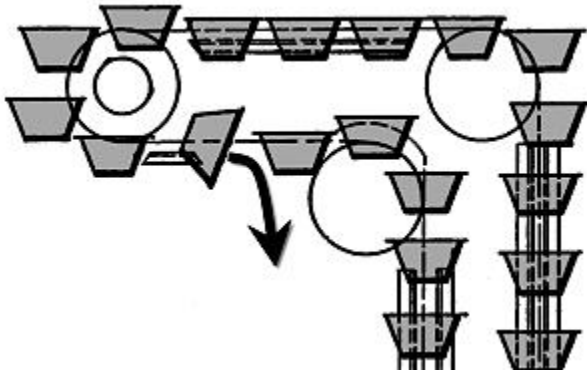
**References****Informative references**

Attention is drawn to the following places, which may be of interest for search:

Construction of buckets conveyor	<a href="#">B65G 17/126</a>
----------------------------------	-----------------------------

**B65G 47/44****Arrangements or applications of hoppers or chutes****Definition statement**

*This place covers:*

Illustrative example of subject matter classified in this group:

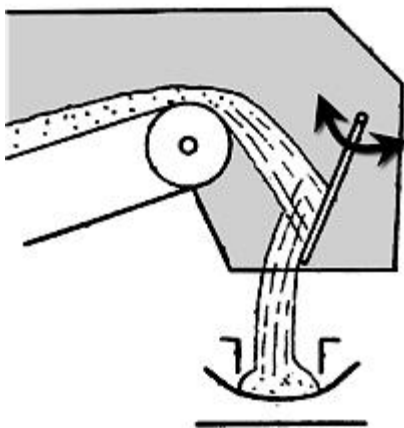

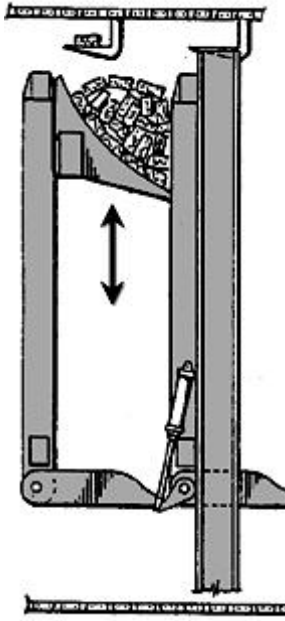

## References

### *Informative references*

*Attention is drawn to the following places, which may be of interest for search:*

Devices for transferring articles or materials between conveyors	<a href="#">B65G 47/52</a>
Fixed platforms or combs	<a href="#">B65G 47/66</a>

**B65G 47/46**

and distributing, e.g. automatically, to desired points (in tube mail systems [B65G 51/36](#))

**Definition statement**

*This place covers:*

Illustrative example of subject matter classified in this group:

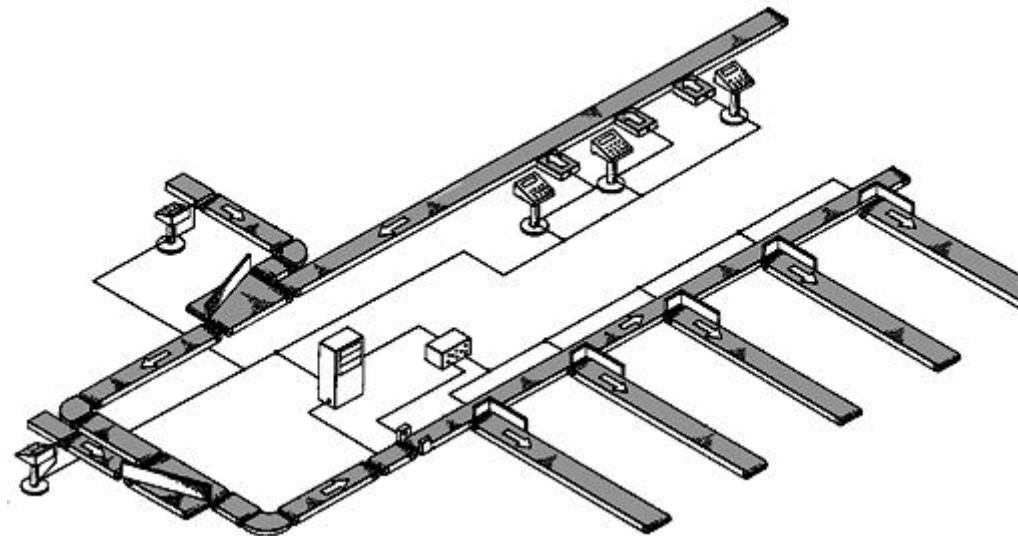
**References****Limiting references**

*This place does not cover:*

In tube mail systems	<a href="#">B65G 51/36</a>
----------------------	----------------------------

**Informative references**

*Attention is drawn to the following places, which may be of interest for search:*

Pivotable chutes	<a href="#">B65G 11/12</a>
Postal sorting or the like	<a href="#">B07C</a>
In railways operations	<a href="#">B61L</a>
Handling sheets or thin flat articles	<a href="#">B65H</a>
Systems or methods specially adapted for administrative, commercial, financial, managerial or supervisory purposes	<a href="#">G06Q</a>



## B65G 47/48

according to bodily destination marks on either articles or load-carriers

### Definition statement

*This place covers:*

Illustrative example of subject matter classified in this group:

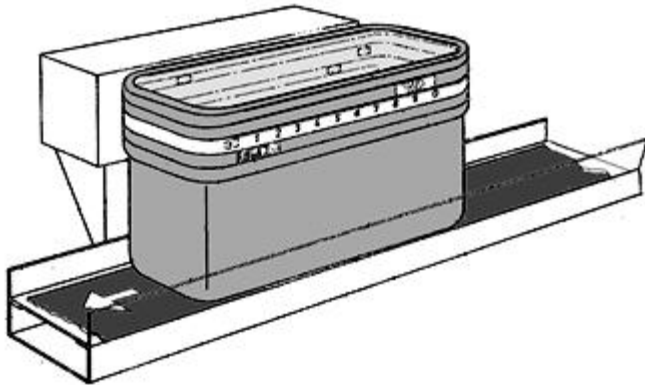

### References

#### *Informative references*

*Attention is drawn to the following places, which may be of interest for search:*

Marking data records	<a href="#">G06K</a>
----------------------	----------------------

## B65G 47/482

{using exclusively mechanical transmitting means between destination marks and switching means}

### Definition statement

*This place covers:*

Illustrative example of subject matter classified in this group:

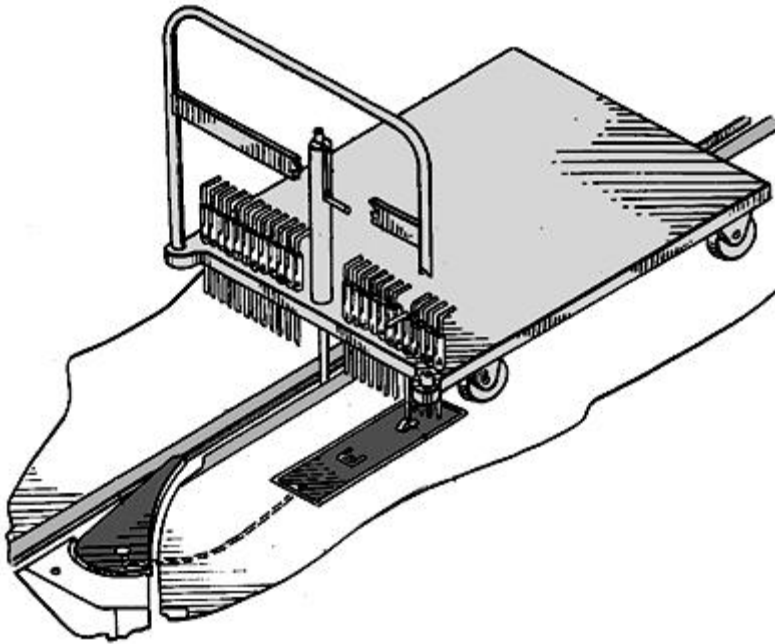

## B65G 47/485

{using electric or electronic transmitting means between destination marks and switching means}

### Definition statement

*This place covers:*

Illustrative example of subject matter classified in this group:

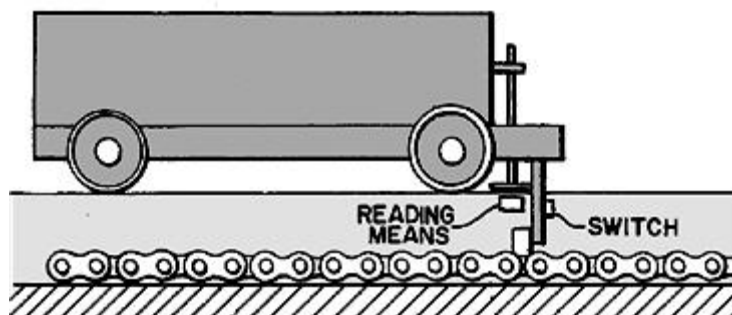

## B65G 47/487

{the destination marks being mechanically detected}

### Definition statement

*This place covers:*

Illustrative example of subject matter classified in this group:

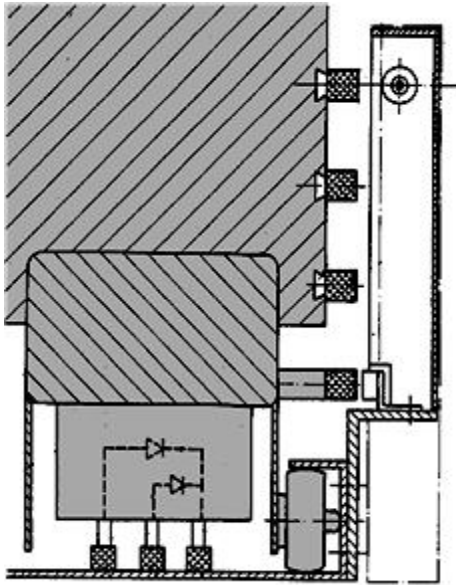

## B65G 47/49

without bodily contact between article or load carrier and automatic control device {, e.g. the destination marks being electrically or electronically detected}

### Definition statement

*This place covers:*

Direct action of the switch after reading the correct code (data not stored in a computer)

Illustrative example of subject matter classified in this group:

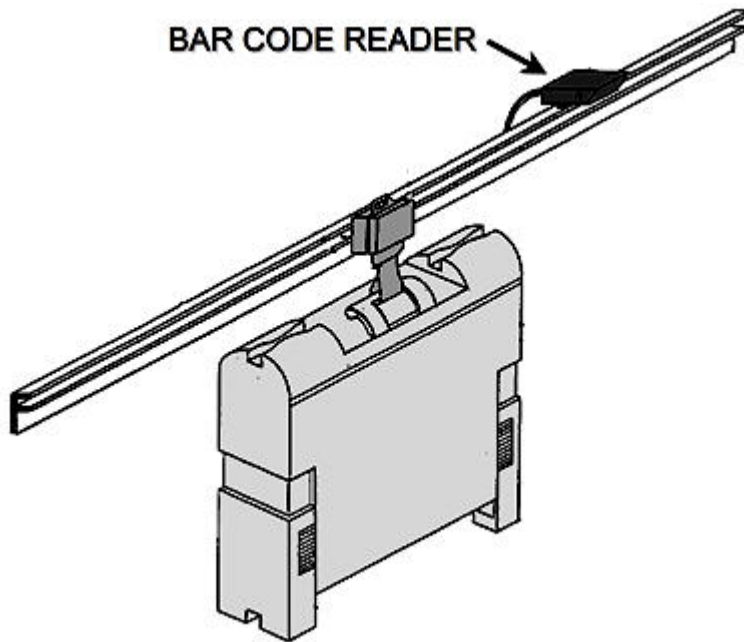

## References

### Informative references

Attention is drawn to the following places, which may be of interest for search:

Methods or arrangements for sensing record carriers	<a href="#">G06K 7/00</a>
-----------------------------------------------------	---------------------------

## B65G 47/493

{by use of light responsive means}

### Definition statement

This place covers:

Illustrative example of subject matter classified in this group:

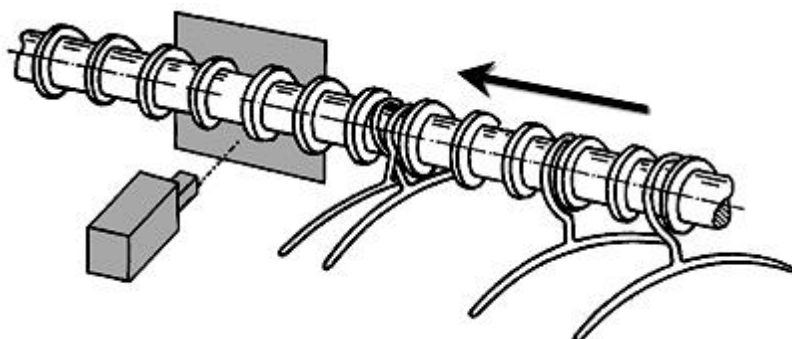

## B65G 47/496

{by use of magnetic responsive means}

### Definition statement

*This place covers:*

Illustrative example of subject matter classified in this group:

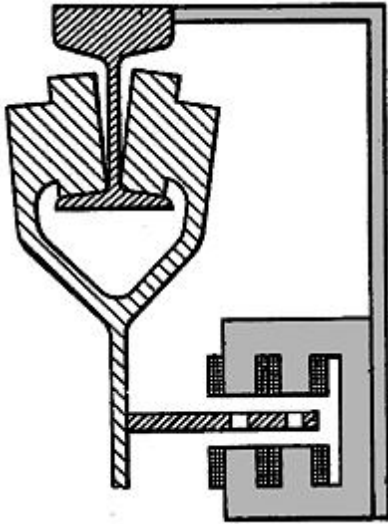

## B65G 47/50

according to destination signals stored in separate systems

### Definition statement

*This place covers:*

Illustrative example of subject matter classified in this group:

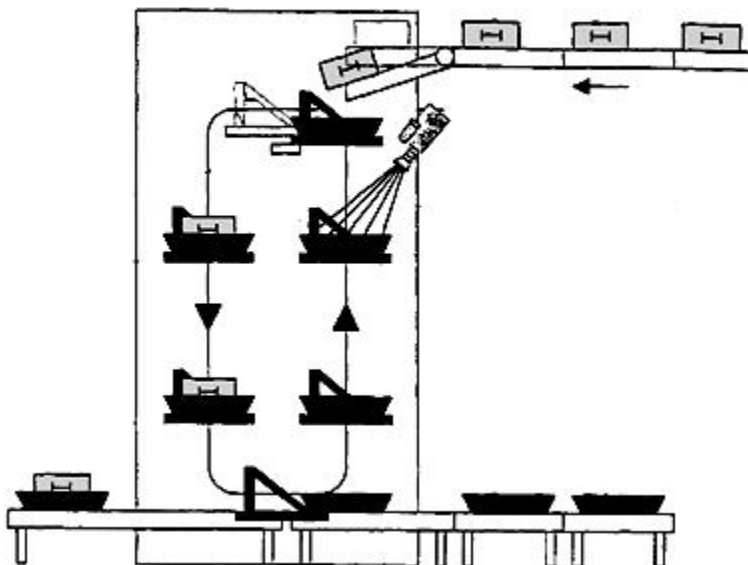

### B65G 47/503

{the system comprising endless moving means}

#### Definition statement

*This place covers:*

Illustrative example of subject matter classified in this group:

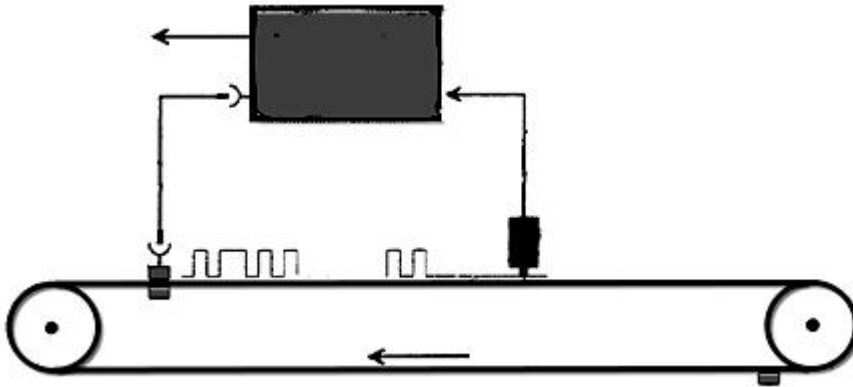

### B65G 47/506

{the system comprising a shift-register}

#### Definition statement

*This place covers:*

Illustrative example of subject matter classified in this group:

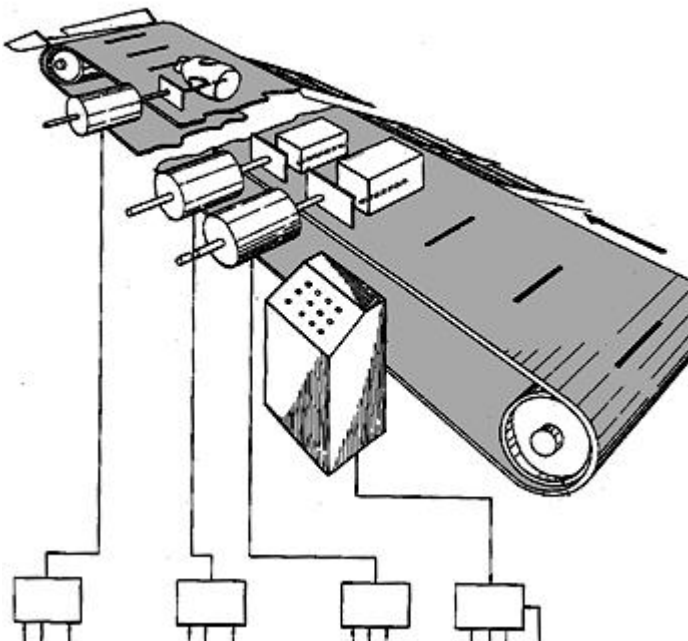

**B65G 47/5104****{for articles}****Definition statement***This place covers:*

Illustrative example of subject matter classified in this group:

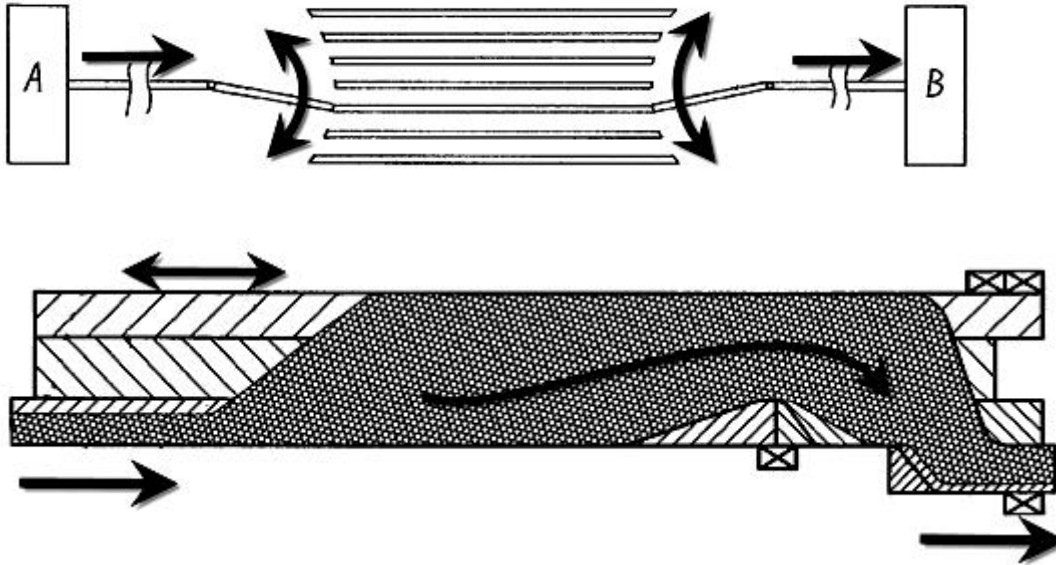
**References****Informative references***Attention is drawn to the following places, which may be of interest for search:*

With recirculation of articles forming a buffer	<a href="#">B65G 47/684</a>
-------------------------------------------------	-----------------------------

**B65G 47/5109****{first In - First Out systems: FIFO}****Definition statement***This place covers:*

FIFO = the order of all incoming articles is maintained at the exit

Illustrative example of subject matter classified in this group:

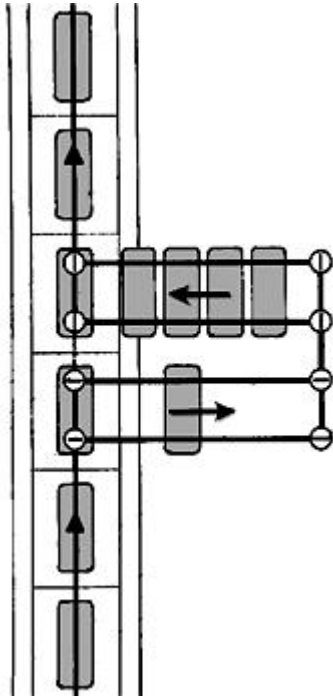

**References**

**Limiting references**

*This place does not cover:*

FIFO = the order of all incoming articles is maintained at the exit otherwise:	<a href="#">B65G 47/5104</a>
--------------------------------------------------------------------------------	------------------------------

**B65G 47/5113**

{using endless conveyors ([B65G 47/5145](#) takes precedence)}

**Definition statement**

*This place covers:*

Illustrative example of subject matter classified in this group:

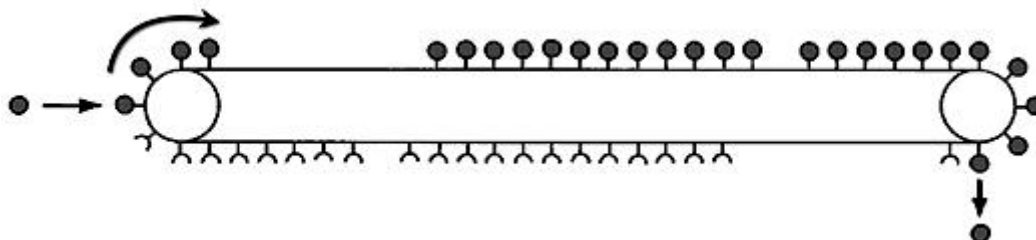



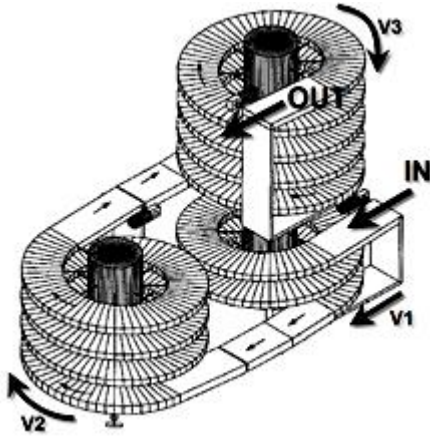

## References

### Informative references

Attention is drawn to the following places, which may be of interest for search:

Grouping articles in rows	<a href="#">B65G 47/082</a>
---------------------------	-----------------------------

## B65G 47/5122

{by displacement of the conveyor-guiding means, e.g. of the loose pulley-type  
([B65G 47/5127](#) takes precedence)}

### Definition statement

*This place covers:*

The configuration of the conveyor changes

Illustrative example of subject matter classified in this group:

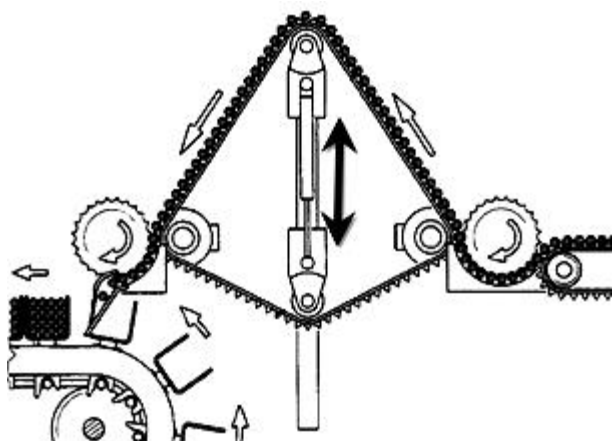

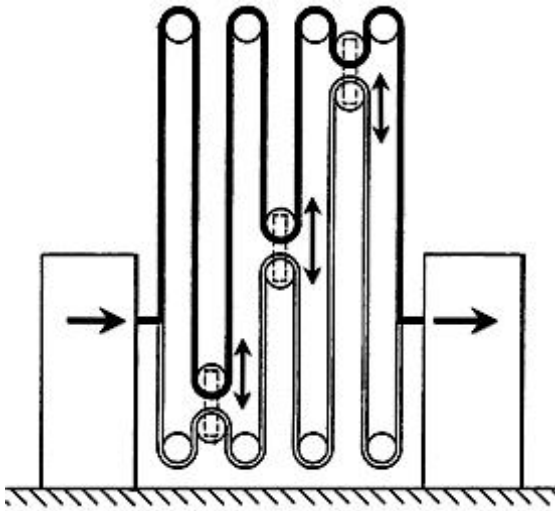

### B65G 47/5127

{by relative displacement between conveyor and input or output}

#### Definition statement

*This place covers:*

Illustrative example of subject matter classified in this group:

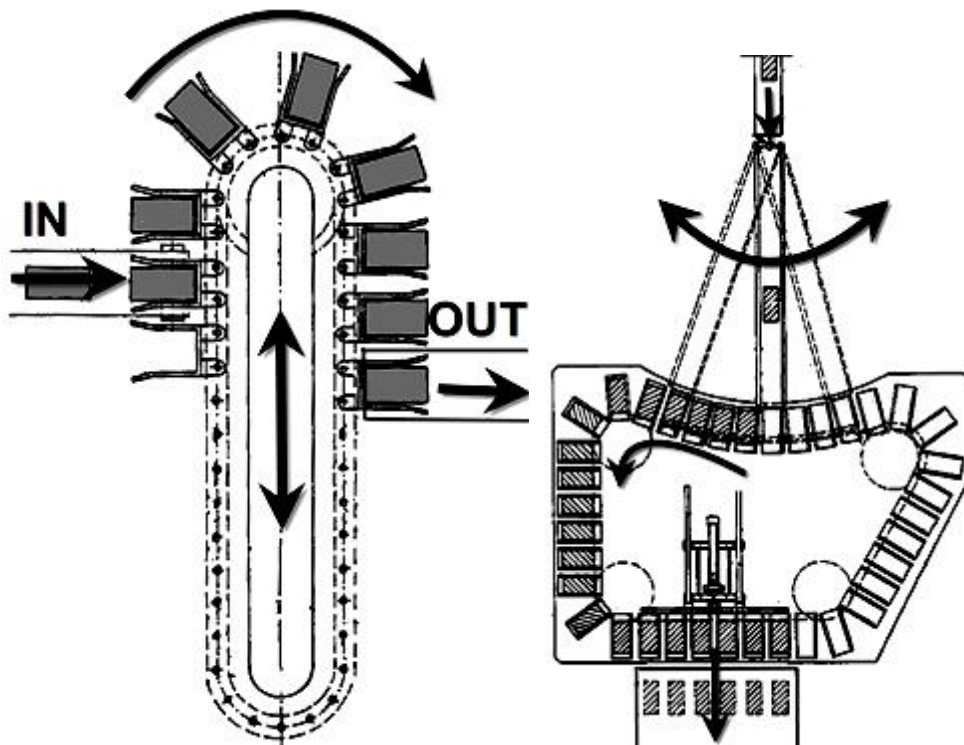

#### References

##### *Informative references*

*Attention is drawn to the following places, which may be of interest for search:*

By displacement of the conveyor-guiding means	<a href="#">B65G 47/5122</a>
-----------------------------------------------	------------------------------

## B65G 47/5131

{by relative displacement between conveyors or conveyor parts and bridging means therebetween}

### Definition statement

*This place covers:*

Illustrative example of subject matter classified in this group:

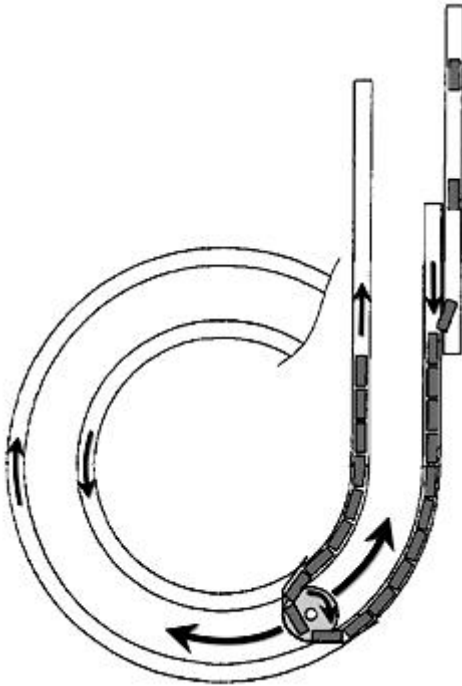

## B65G 47/5136

{using rotary conveyors}

### Definition statement

*This place covers:*

The storing device is a rotary conveyor

Illustrative example of subject matter classified in this group:

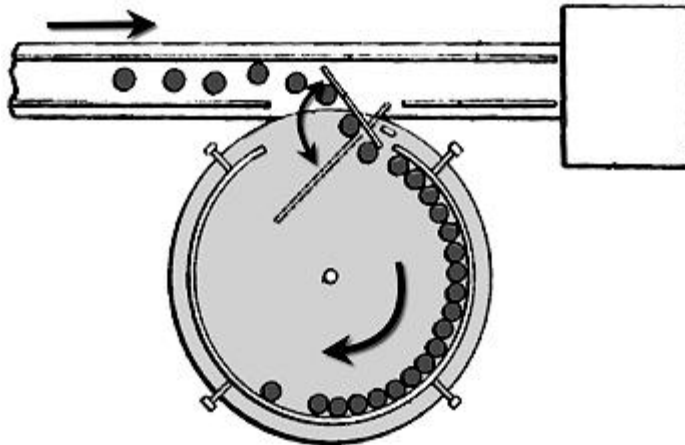

## B65G 47/514

{using stacking and/or destacking arrangements or stacks of articles or article carriers}

### Definition statement

*This place covers:*

Illustrative example of subject matter classified in this group:

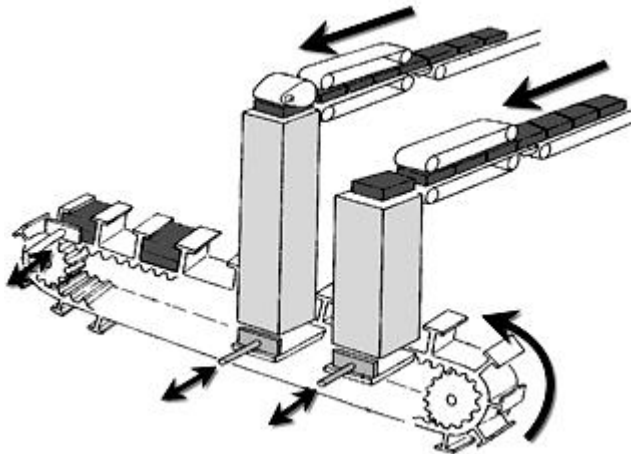

## References

### Informative references

*Attention is drawn to the following places, which may be of interest for search:*

Using stacking or destacking arrangements or stacks of articles or article-carriers	<a href="#">B65G 47/5181</a>
-------------------------------------------------------------------------------------	------------------------------

**B65G 47/5145****{with recirculation means}****Definition statement***This place covers:*

Illustrative example of subject matter classified in this group:

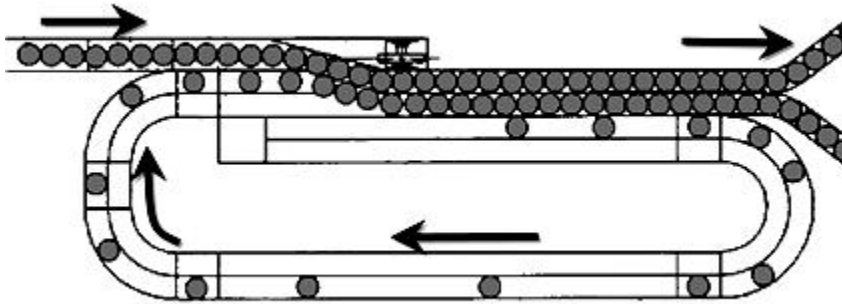
**References****Informative references***Attention is drawn to the following places, which may be of interest for search:*

Rotary disk conveyor	<a href="#">B65G 47/5136</a>
----------------------	------------------------------

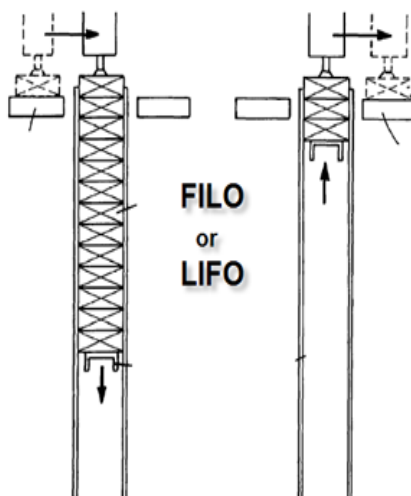
**B65G 47/515****{First In-Last Out systems [FILO]; Last In-First Out systems [LIFO]}****Definition statement***This place covers:*

## References

### Limiting references

*This place does not cover:*

FILO = the order of all outgoing articles is precisely the opposite of the order of the incoming articles ( otherwise:	<a href="#">B65G 47/5104</a>
------------------------------------------------------------------------------------------------------------------------	------------------------------

## B65G 47/5154

{using endless conveyors ([B65G 47/5186](#) takes precedence)}

### Definition statement

*This place covers:*

Illustrative example of subject matter classified in this group:

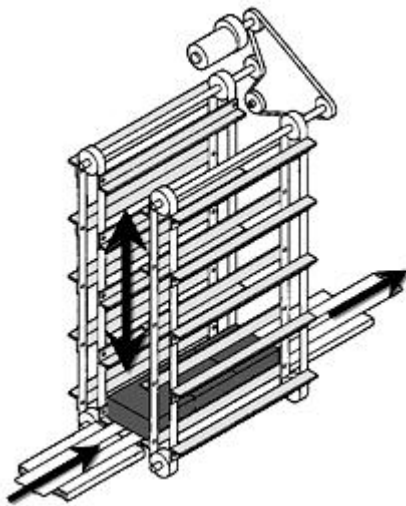

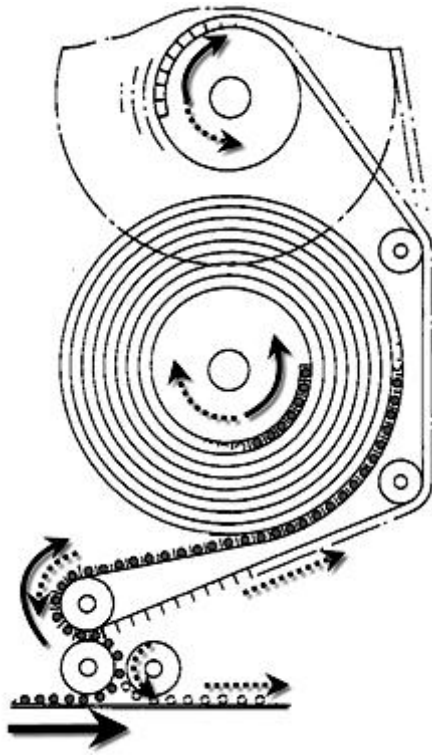

**B65G 47/5159**

{with variable accumulation capacity}

**Definition statement**

*This place covers:*

Illustrative example of subject matter classified in this group:

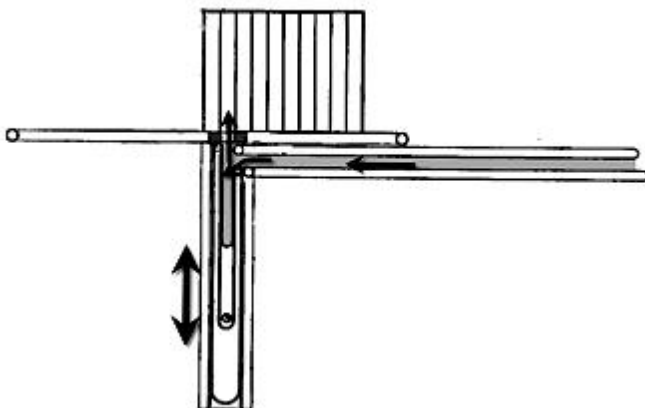

## B65G 47/5177

{using rotary conveyor(s)}

### Definition statement

*This place covers:*

Illustrative example of subject matter classified in this group:

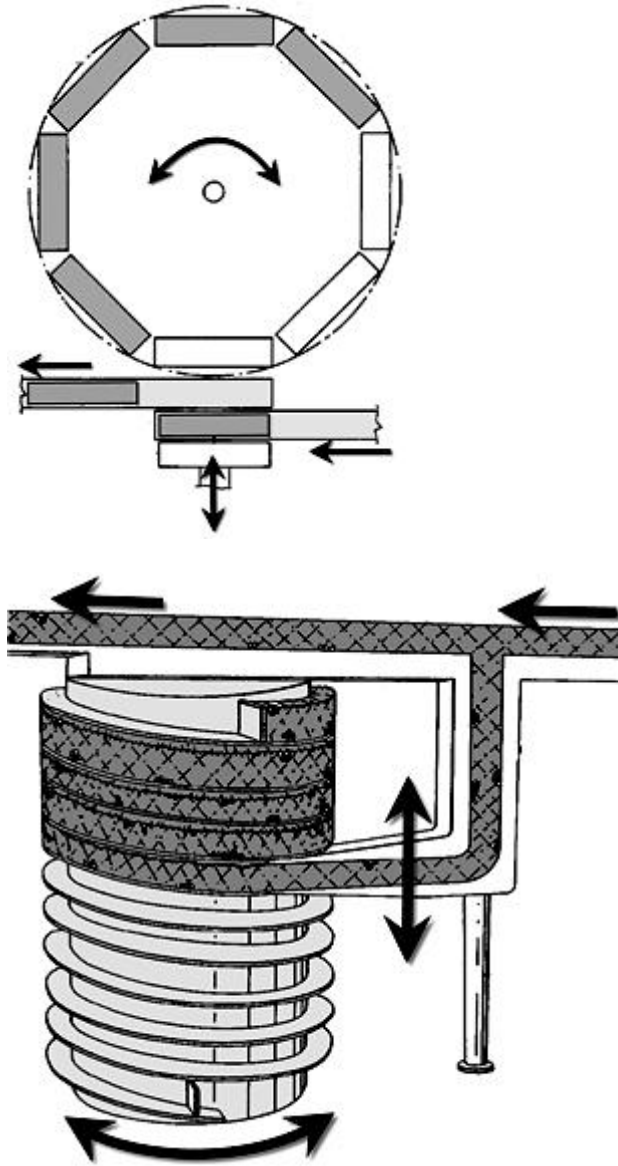



**B65G 47/5181**

{using stacking or destacking arrangements or stacks of articles or article-carriers}

**Definition statement**

*This place covers:*

Illustrative example of subject matter classified in this group:

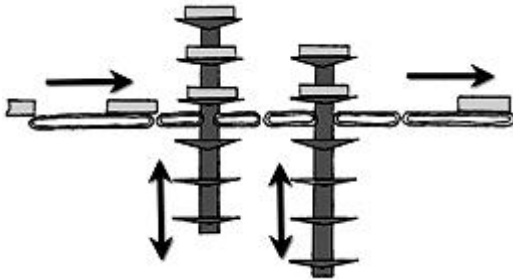
**B65G 47/5186**

{with recirculation means}

**Definition statement**

*This place covers:*

Illustrative example of subject matter classified in this group:

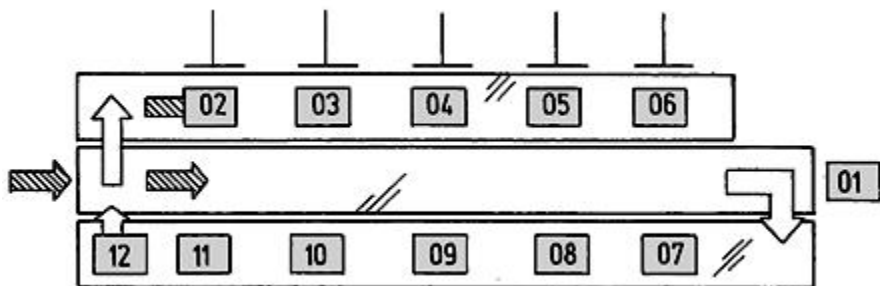

**B65G 47/519****{collecting tables or bins as end-station}****Definition statement***This place covers:*

Illustrative example of subject matter classified in this group:

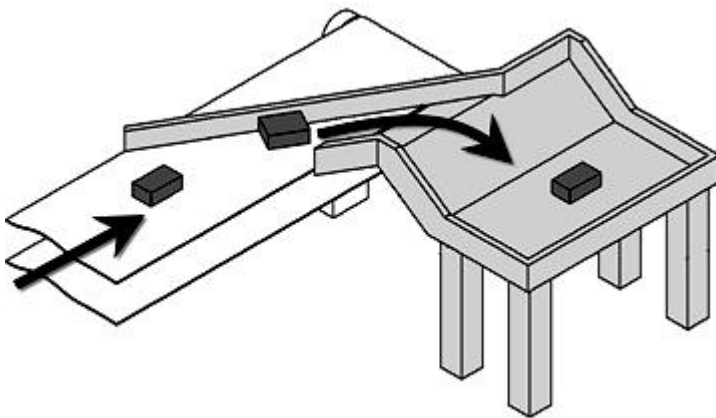
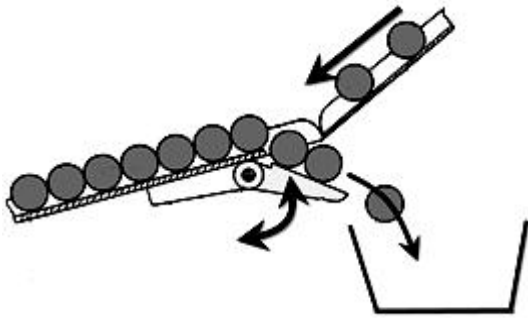
**B65G 47/5195****{for materials in bulk}****Definition statement***This place covers:*

Illustrative example of subject matter classified in this group:

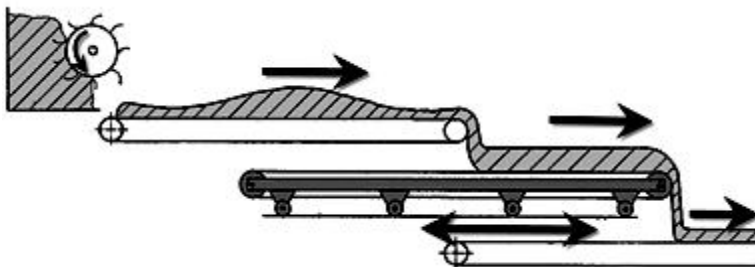

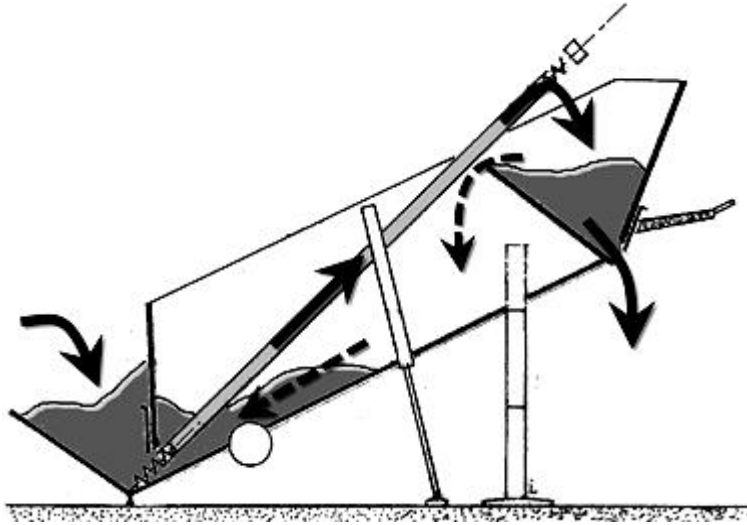

## References

### *Informative references*

*Attention is drawn to the following places, which may be of interest for search:*

Arrangements or applications of hoppers or chutes having means for controlling material flow	<a href="#">B65G 47/19</a>
----------------------------------------------------------------------------------------------	----------------------------

## B65G 47/52

Devices for transferring articles or materials between conveyors i.e. discharging or feeding devices (loading or unloading by means not incorporated in, or not operatively associated with, conveyors [B65G 65/00](#); transfer of workpieces during metal rolling [B21B 41/00](#))

### Definition statement

*This place covers:*

Illustrative example of subject matter classified in this group:

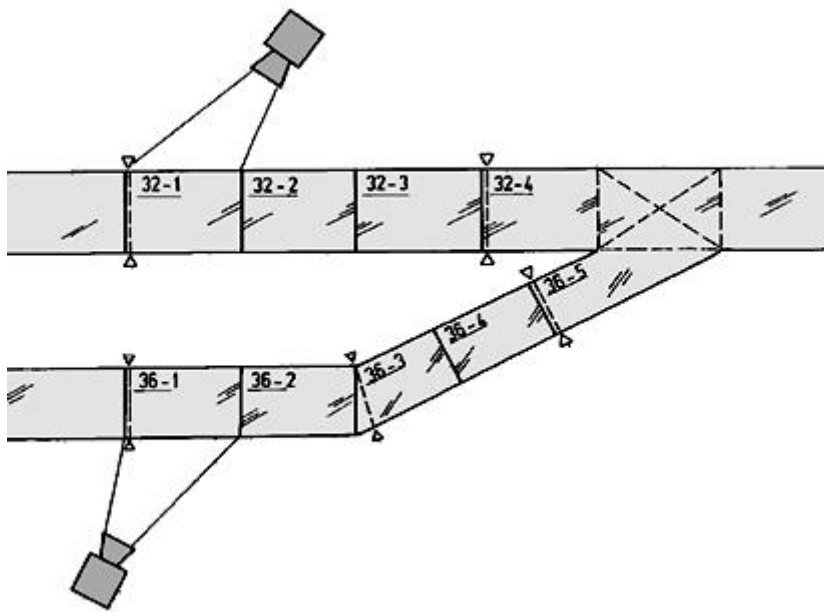

### References

#### Limiting references

*This place does not cover:*

Loading or unloading by means not incorporated in, or not operatively associated with, conveyors	<a href="#">B65G 65/00</a>
Transfer of workpieces during metal rolling	<a href="#">B21B 41/00</a>

**B65G 47/525****{using fluid jets}****Definition statement***This place covers:*

Illustrative example of subject matter classified in this group:

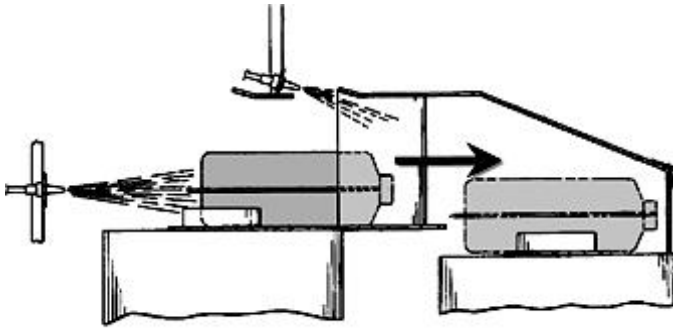
**References****Informative references***Attention is drawn to the following places, which may be of interest for search:*

Sorting	<a href="#">B07C 5/363</a>
---------	----------------------------

**B65G 47/53****between conveyors which cross one another****Definition statement***This place covers:*

Illustrative example of subject matter classified in this group:

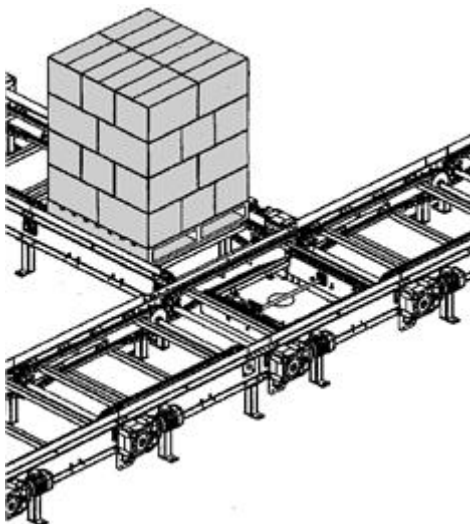

## References

### Informative references

Attention is drawn to the following places, which may be of interest for search:

Pallets on a closed track	<a href="#">B65G 35/06</a>
---------------------------	----------------------------

## B65G 47/54

at least one of which is a roller-way

### Definition statement

*This place covers:*

Illustrative example of subject matter classified in this group:

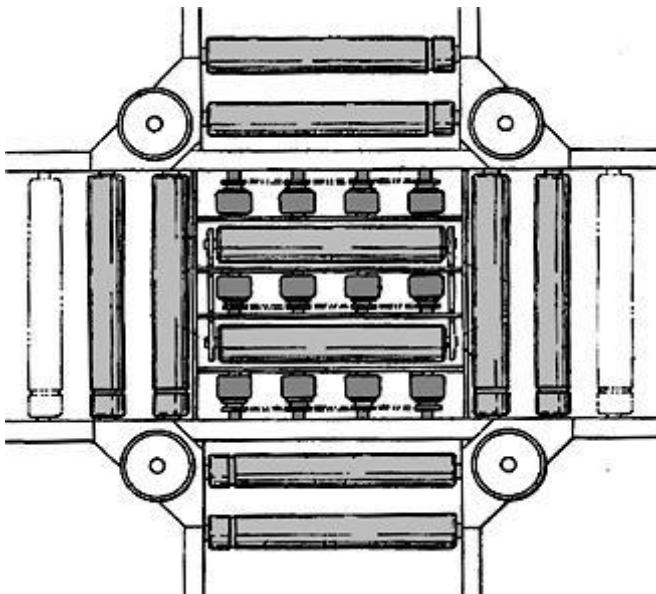

## References

### Informative references

Attention is drawn to the following places, which may be of interest for search:

Switching arrangements	<a href="#">B65G 13/10</a>
Having spherical roller elements	<a href="#">B65G 39/025</a>

## B65G 47/57

for articles

### Definition statement

*This place covers:*

Devices transferring discrete articles to or from inclined or vertical conveyor sections. These devices and conveyors have usually different inherent features than those destined for bulk (powdery, ore, etc) material.

Illustrative example of subject matter classified in this group:

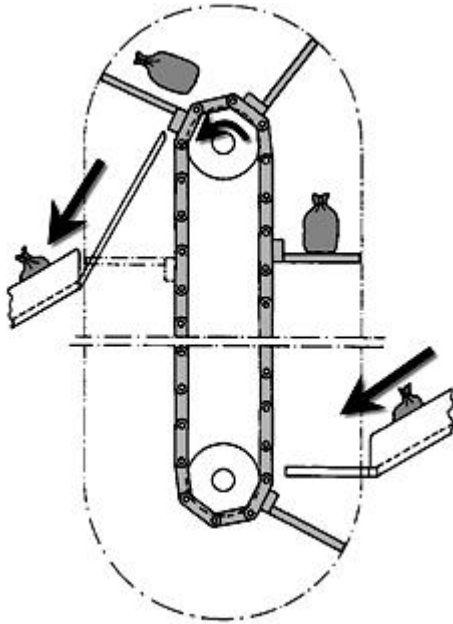

## References

### *Informative references*

*Attention is drawn to the following places, which may be of interest for search:*

Arranged to keep the load-carriers horizontally during at least a part of the conveyor run	<a href="#">B65G 17/123</a>
--------------------------------------------------------------------------------------------	-----------------------------

## **B65G 47/58**

**for materials in bulk**

### **Definition statement**

*This place covers:*

Devices transferring bulk (powdery, ore, etc) material to or from inclined or vertical conveyor sections. These devices and conveyors have usually different inherent features than those destined for discrete articles.

Illustrative example of subject matter classified in this group:

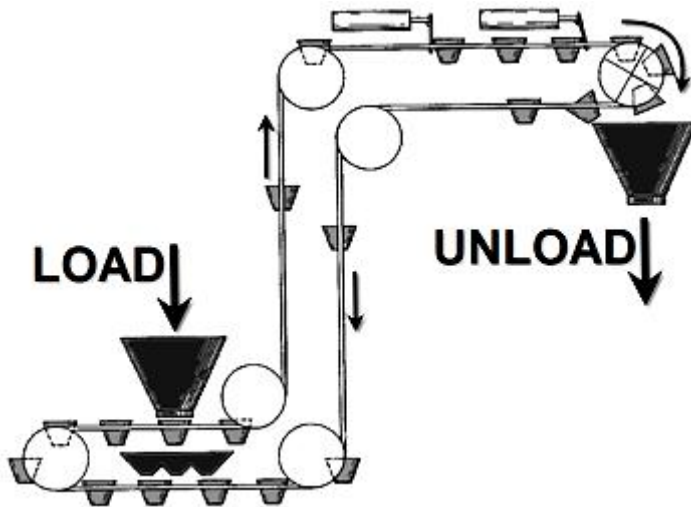

## References

### Informative references

Attention is drawn to the following places, which may be of interest for search:

Bucket conveyor	<a href="#">B65G 17/126</a>
Tilting buckets	<a href="#">B65G 47/40</a>

## B65G 47/61

for articles

### Definition statement

*This place covers:*

Devices transferring discrete articles to or from inclined or vertical conveyor sections. These devices and conveyors have usually different inherent features than those destined for bulk (powdery, ore, etc) material.

Illustrative example of subject matter classified in this group:

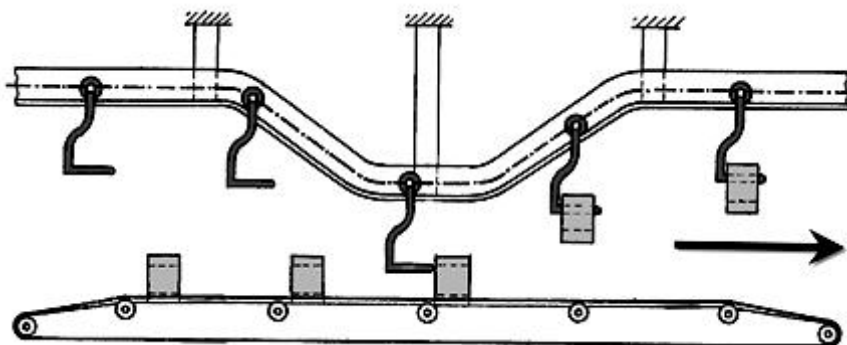



## References

### *Informative references*

Attention is drawn to the following places, which may be of interest for search:

Clotheshanger	<a href="#">B65G 2201/0229</a>
---------------	--------------------------------

## B65G 47/62

### for materials in bulk

### Definition statement

*This place covers:*

Devices transferring bulk (powdery, ore, etc) material to or from inclined or vertical conveyor sections. These devices and conveyors have usually different inherent features than those destined for discrete articles.

Illustrative example of subject matter classified in this group:

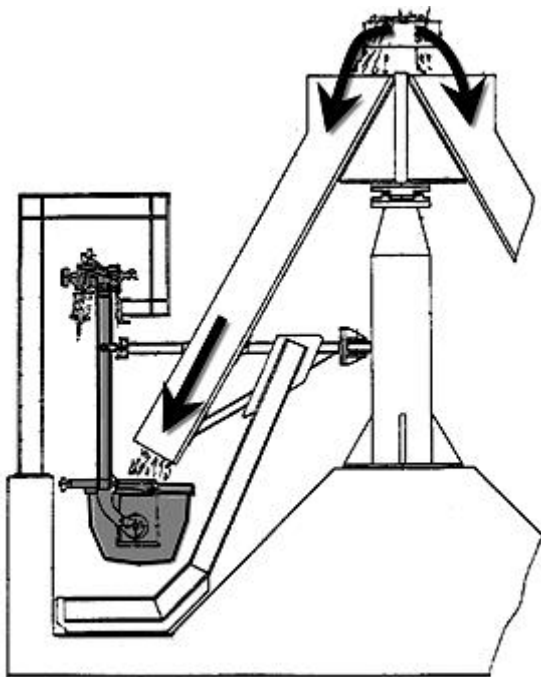

## References

### *Informative references*

Attention is drawn to the following places, which may be of interest for search:

Bucket elevators	<a href="#">B65G 47/58</a>
------------------	----------------------------

**B65G 47/64****Switching conveyors****References****Limiting references**

*This place does not cover:*

Switch guides (scraper) in a conveyor line	<a href="#">B65G 47/76</a>
--------------------------------------------	----------------------------

**Informative references**

*Attention is drawn to the following places, which may be of interest for search:*

For articles	<a href="#">B65G 47/71</a>
For bulk	<a href="#">B65G 47/72</a>
Pneumatic conveyors	<a href="#">B65G 53/56</a>

**B65G 47/642**

**{in a horizontal plane}**

**Definition statement**

*This place covers:*

Illustrative example of subject matter classified in this group:

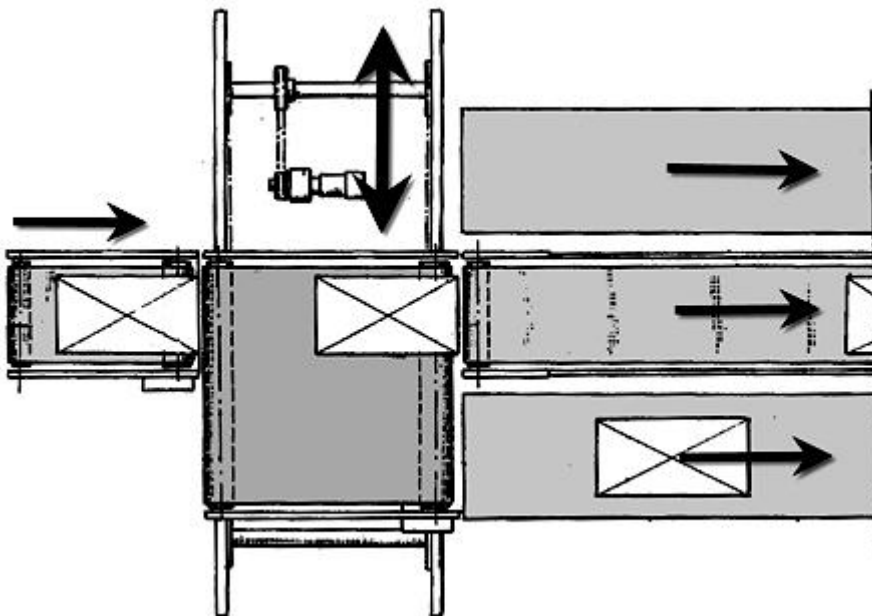

**B65G 47/643****{in a vertical plane}****Definition statement***This place covers:*

Illustrative example of subject matter classified in this group:

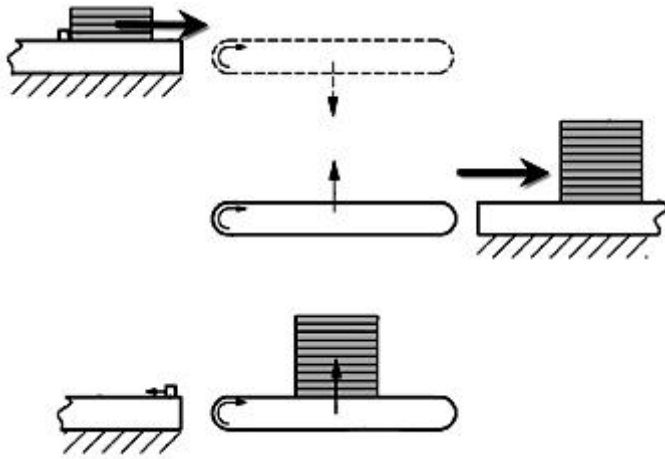
**References****Informative references***Attention is drawn to the following places, which may be of interest for search:*

For articles	<a href="#">B65G 53/56</a>
--------------	----------------------------

**B65G 47/646****{the axis being parallel to the conveying direction}****Definition statement***This place covers:*

Illustrative example of subject matter classified in this group:

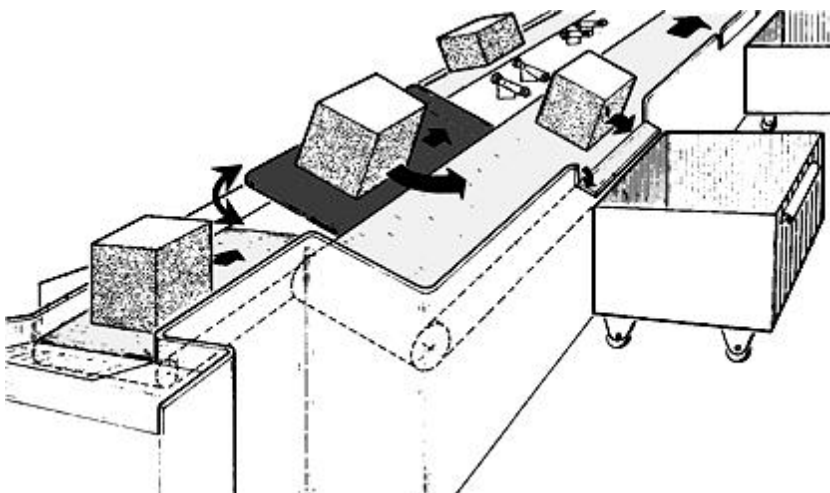

## References

### Informative references

Attention is drawn to the following places, which may be of interest for search:

Devices for tilting links or platform	<a href="#">B65G 47/96</a>
---------------------------------------	----------------------------

## B65G 47/647

{the axis being perpendicular to the conveying direction}

### Definition statement

This place covers:

Illustrative example of subject matter classified in this group:

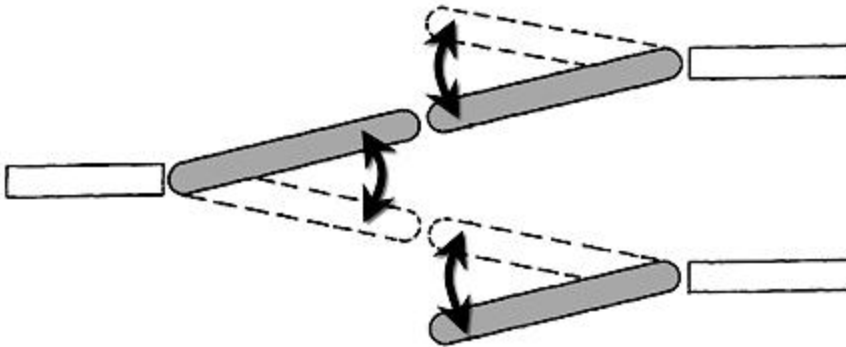

## B65G 47/648

{about a vertical axis}

### Definition statement

This place covers:

Illustrative example of subject matter classified in this group:

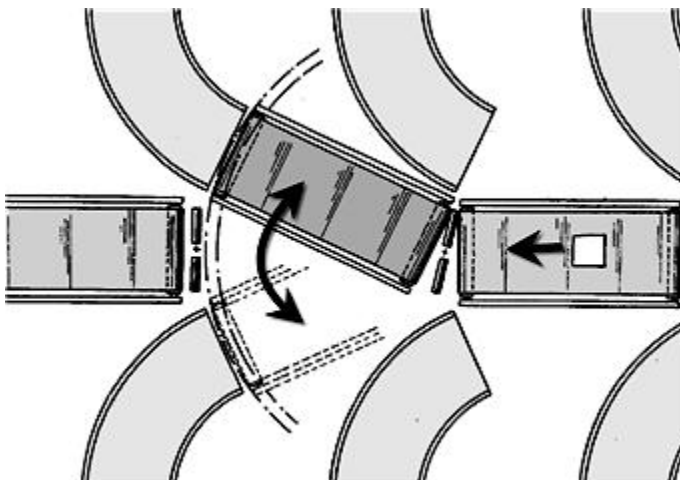

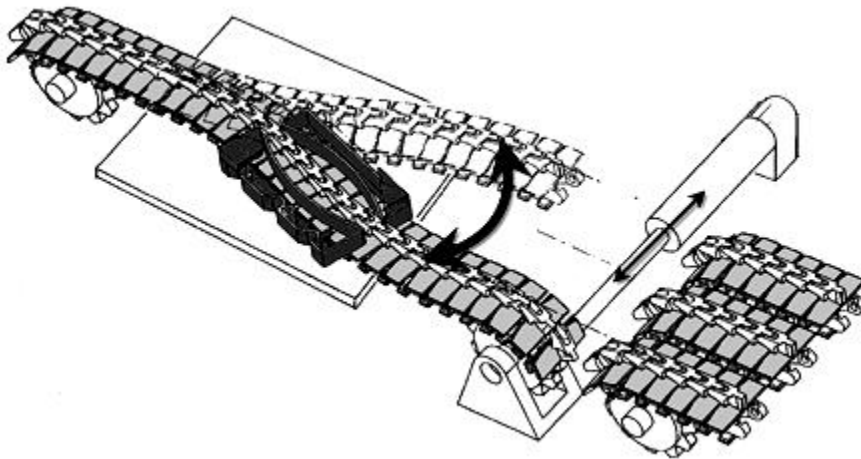

## References

### *Informative references*

*Attention is drawn to the following places, which may be of interest for search:*

Switching conveyors in a horizontal plane	<a href="#">B65G 47/642</a>
-------------------------------------------	-----------------------------

## **B65G 47/66**

**Fixed platforms or combs, e.g. bridges between conveyors**

### **Definition statement**

*This place covers:*

Illustrative example of subject matter classified in this group:

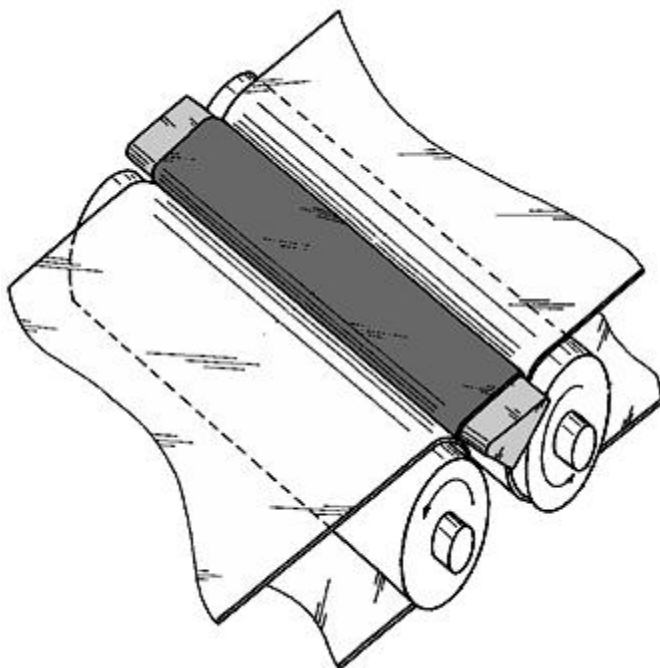

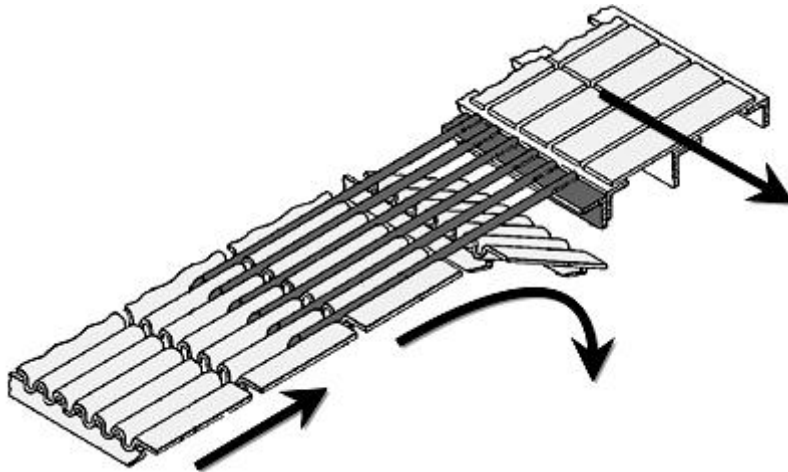

### B65G 47/68

adapted to receive articles arriving in one layer from one conveyor {lane} and to transfer them in individual layers to more than one conveyor {lane or to one broader conveyor lane}, or vice versa, e.g. combining the flows of articles conveyed by more than one conveyor

#### Definition statement

*This place covers:*

Illustrative example of subject matter classified in this group:

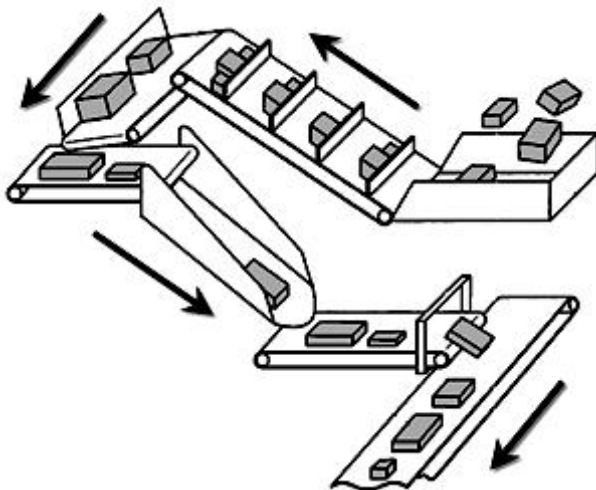

#### Special rules of classification

Series of different conveyors in different directions to arrange articles in a row.

**B65G 47/681****{from distinct, separate conveyor lanes}****Definition statement***This place covers:*

Illustrative example of subject matter classified in this group:

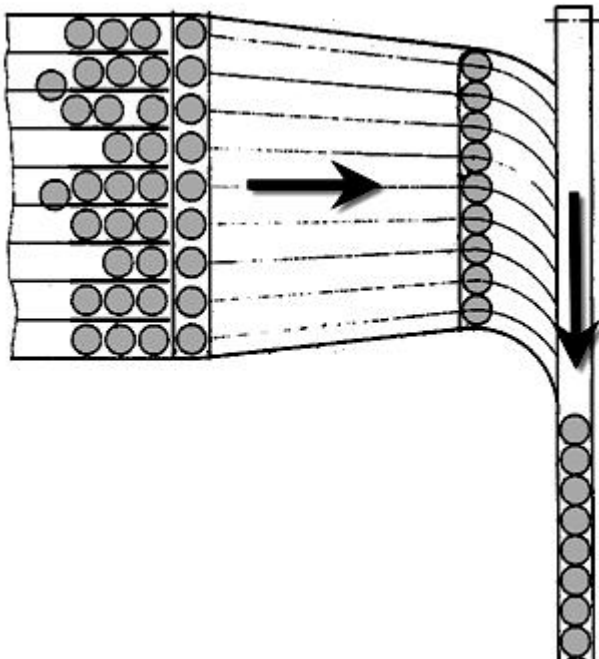
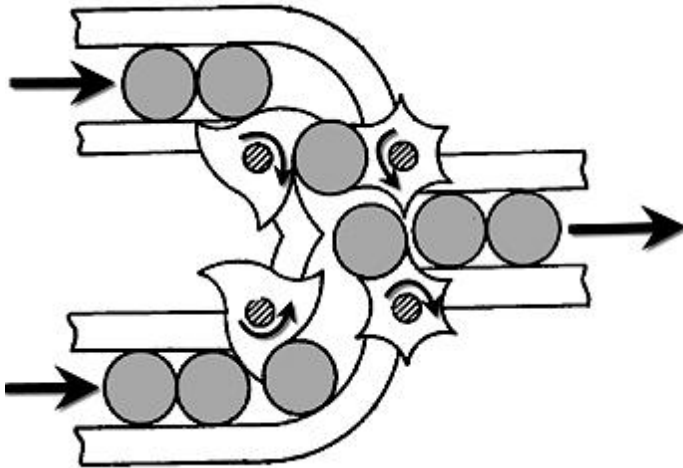
**References****Informative references***Attention is drawn to the following places, which may be of interest for search:*

Devices for transferring articles or materials between conveyors	<a href="#">B65G 47/52</a>
Devices for preventing jamming in converging flows	<a href="#">B65G 2047/685</a>
Control of the drive of the conveyors	<a href="#">B65G 47/70</a>



**B65G 47/682**

{from a single conveyor lane consisting of one conveyor or several adjacent conveyors}

**Definition statement**

*This place covers:*

Illustrative example of subject matter classified in this group:

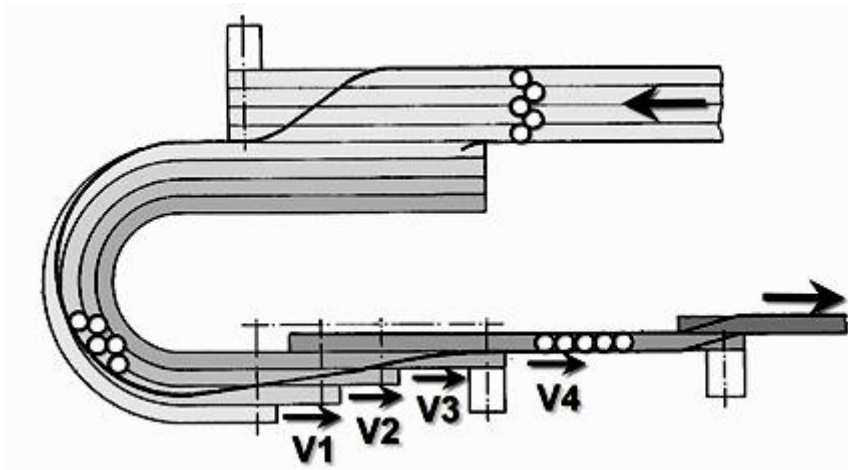
**References****Informative references**

*Attention is drawn to the following places, which may be of interest for search:*

Accumulating articles by varying the relative speeds of the conveyors forming the serie	<a href="#">B65G 47/31</a>
Guides for preventing jamming	<a href="#">B65G 2047/685</a>



**B65G 47/683**

{with tilting of at least part of the conveyor to make use of gravity}

**Definition statement**

*This place covers:*

Illustrative example of subject matter classified in this group:

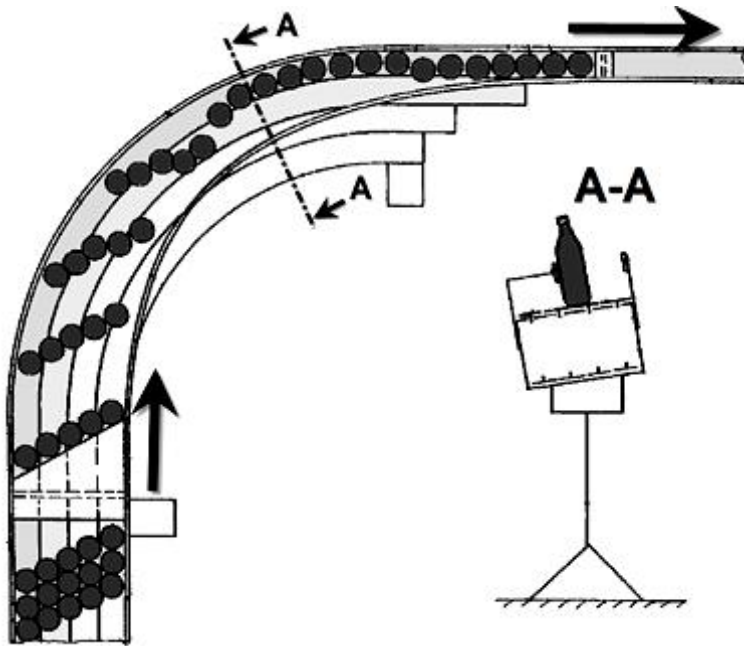
**References****Limiting references**

*This place does not cover:*

Inclined conveyor in general	<a href="#">B65G 47/68</a>
------------------------------	----------------------------

**B65G 47/684****{with recirculation of articles forming a buffer}****Definition statement***This place covers:*

Illustrative example of subject matter classified in this group:

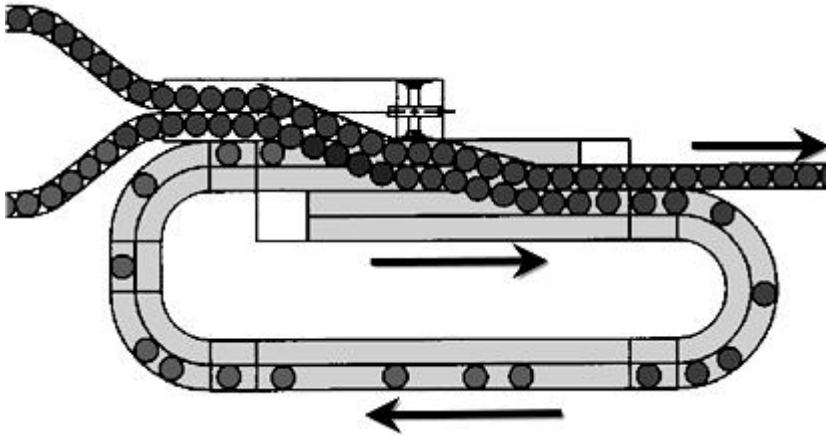
**References****Informative references***Attention is drawn to the following places, which may be of interest for search:*

First In - First Out systems: FIFO	<a href="#">B65G 47/5109</a>
------------------------------------	------------------------------

**B65G 47/69****the articles being accumulated temporarily {(accumulating articles during transit [B65G 47/261](#))}****References****Informative references***Attention is drawn to the following places, which may be of interest for search:*

According to unprogrammed signals, e.g. influenced by supply situation at destination for articles	<a href="#">B65G 47/5104</a> - <a href="#">B65G 47/519</a>
With precedence controls among incoming article flows	<a href="#">B65G 47/70</a>

**B65G 47/70**

with precedence controls among incoming article flows

**Definition statement**

*This place covers:*

Illustrative example of subject matter classified in this group:

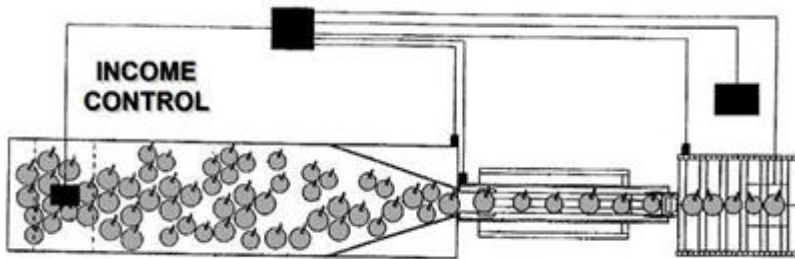
**References****Informative references**

Attention is drawn to the following places, which may be of interest for search:

Control of free space to transfer	<a href="#">B65G 47/52</a>
From distinct, separate conveyor lanes	<a href="#">B65G 47/681</a>

**B65G 47/71**

the articles being discharged {or distributed} to several {distinct separate} conveyors {or to a broader conveyor lane}

**Definition statement**

*This place covers:*

Only separated conveyor lanes

Illustrative example of subject matter classified in this group:

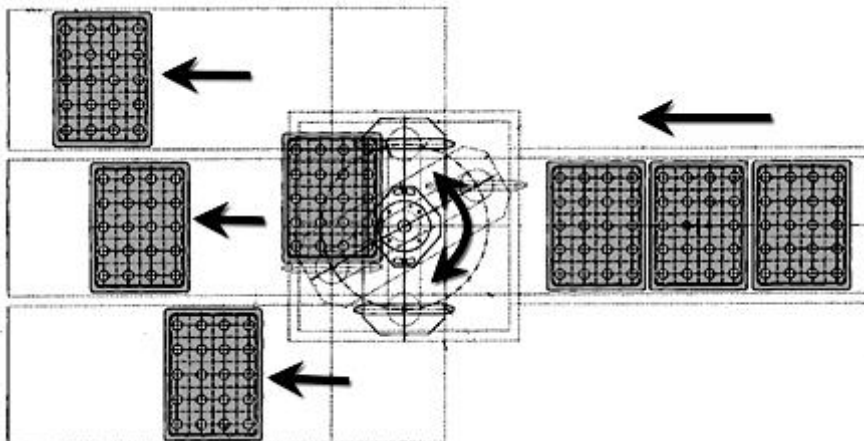

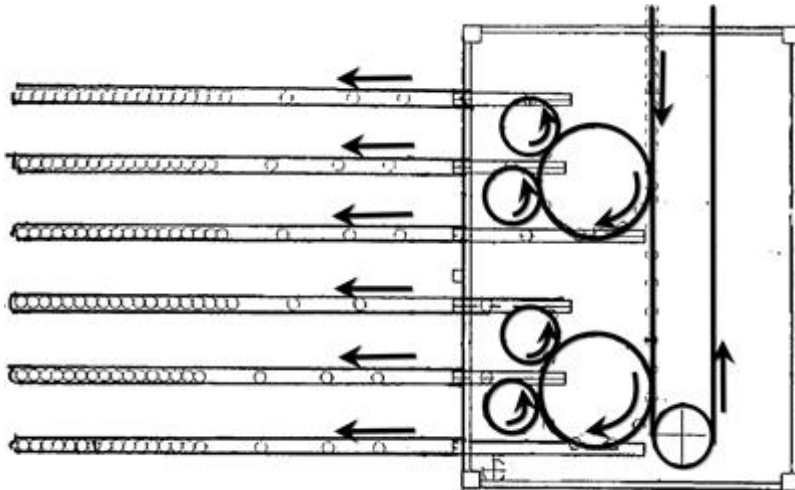

## References

### Informative references

Attention is drawn to the following places, which may be of interest for search:

Switches	<a href="#">B65G 47/64</a>
Pusher shoes	<a href="#">B65G 47/844</a>

### Special rules of classification

Not separated conveyor lanes are classified in [B65G 47/715](#).

## B65G 47/715

{to a broader conveyor lane}

### Definition statement

*This place covers:*

Illustrative example of subject matter classified in this group:

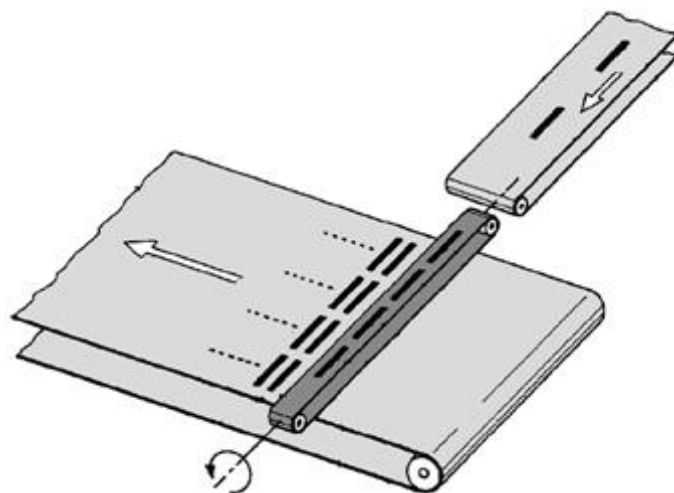

## References

### Limiting references

*This place does not cover:*

Separated conveyor lanes	<a href="#">B65G 47/71</a>
--------------------------	----------------------------

### Special rules of classification

Opposite of [B65G 47/682](#).

## B65G 47/72

transferring materials in bulk from one conveyor to several conveyors, or vice versa

### Definition statement

*This place covers:*

Illustrative example of subject matter classified in this group:

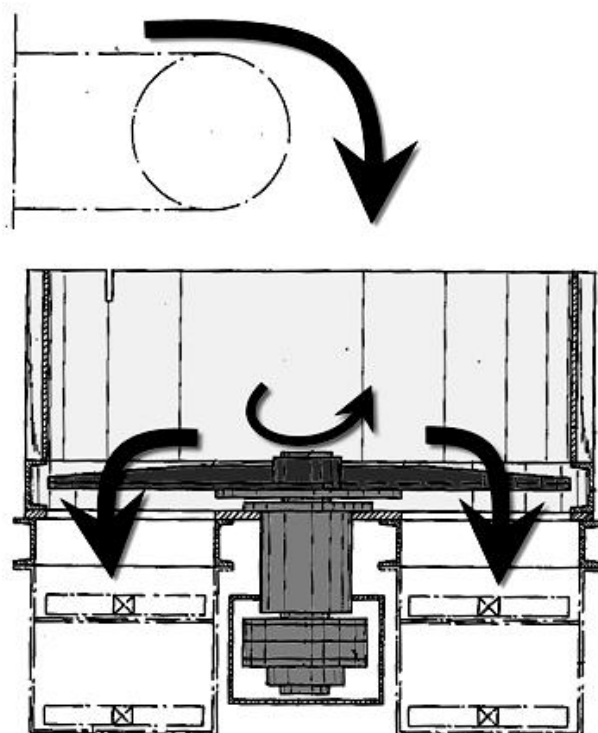

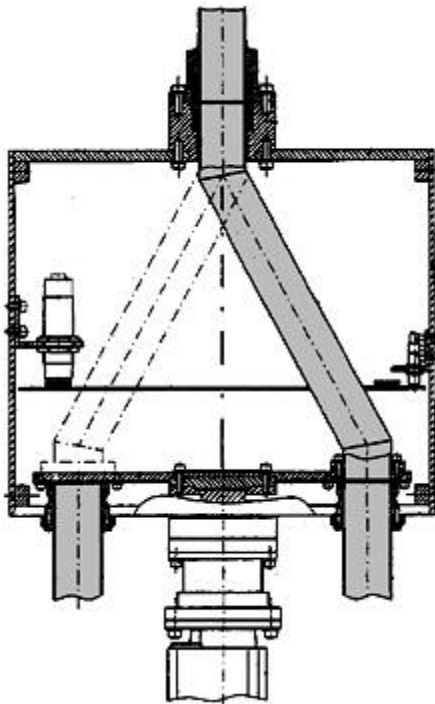

## References

### Informative references

Attention is drawn to the following places, which may be of interest for search:

For making a homogeneous pile	<a href="#">B65G 69/10</a>
-------------------------------	----------------------------

## B65G 47/74

Feeding, transfer, or discharging devices of particular kinds or types

### Definition statement

This place covers:

Illustrative example of subject matter classified in this group:

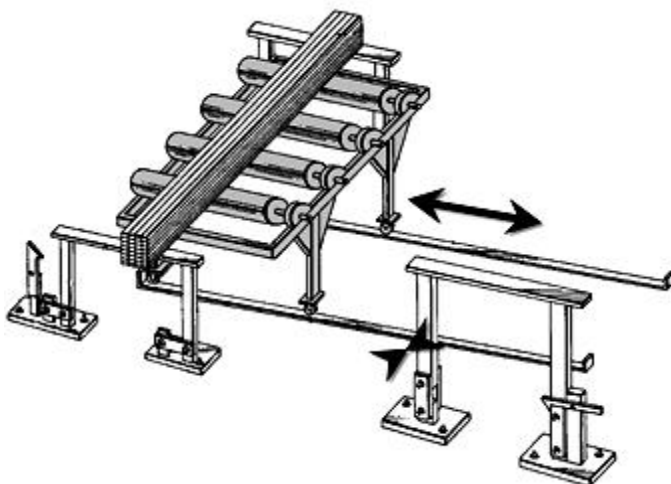

**B65G 47/763****{Fixed ploughs or transverse scrapers}****Definition statement***This place covers:*

Only scrapers which are not actuated and which do not comprise any actuated part.

Illustrative example of subject matter classified in this group:

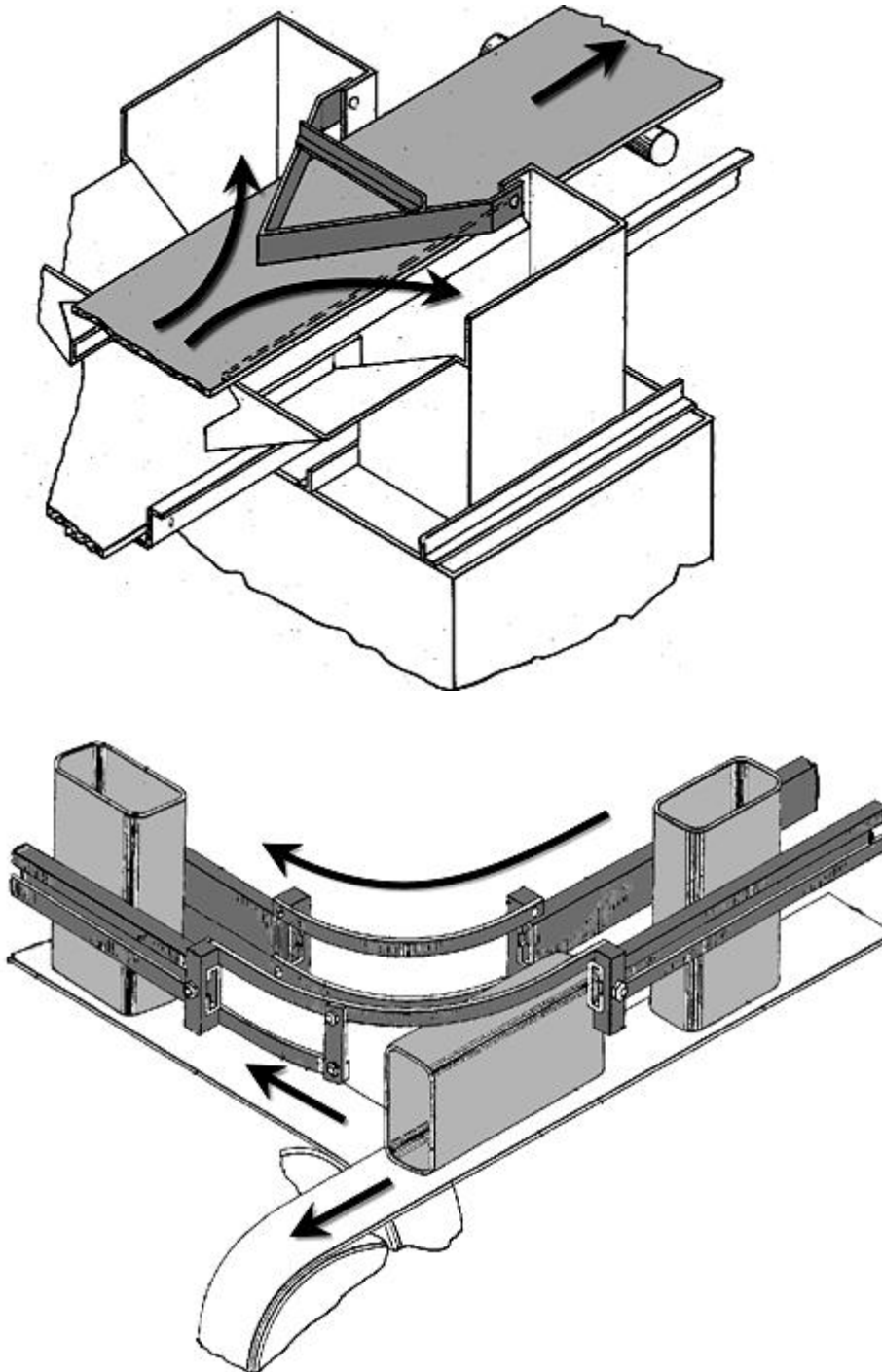



**References**

**Limiting references**

*This place does not cover:*

NOT Scrapers which are not actuated and which do not comprise any actuated part	<a href="#">B65G 47/766</a>
---------------------------------------------------------------------------------	-----------------------------

**B65G 47/766**

{Adjustable ploughs or transverse scrapers}

**Definition statement**

*This place covers:*

Illustrative example of subject matter classified in this group:

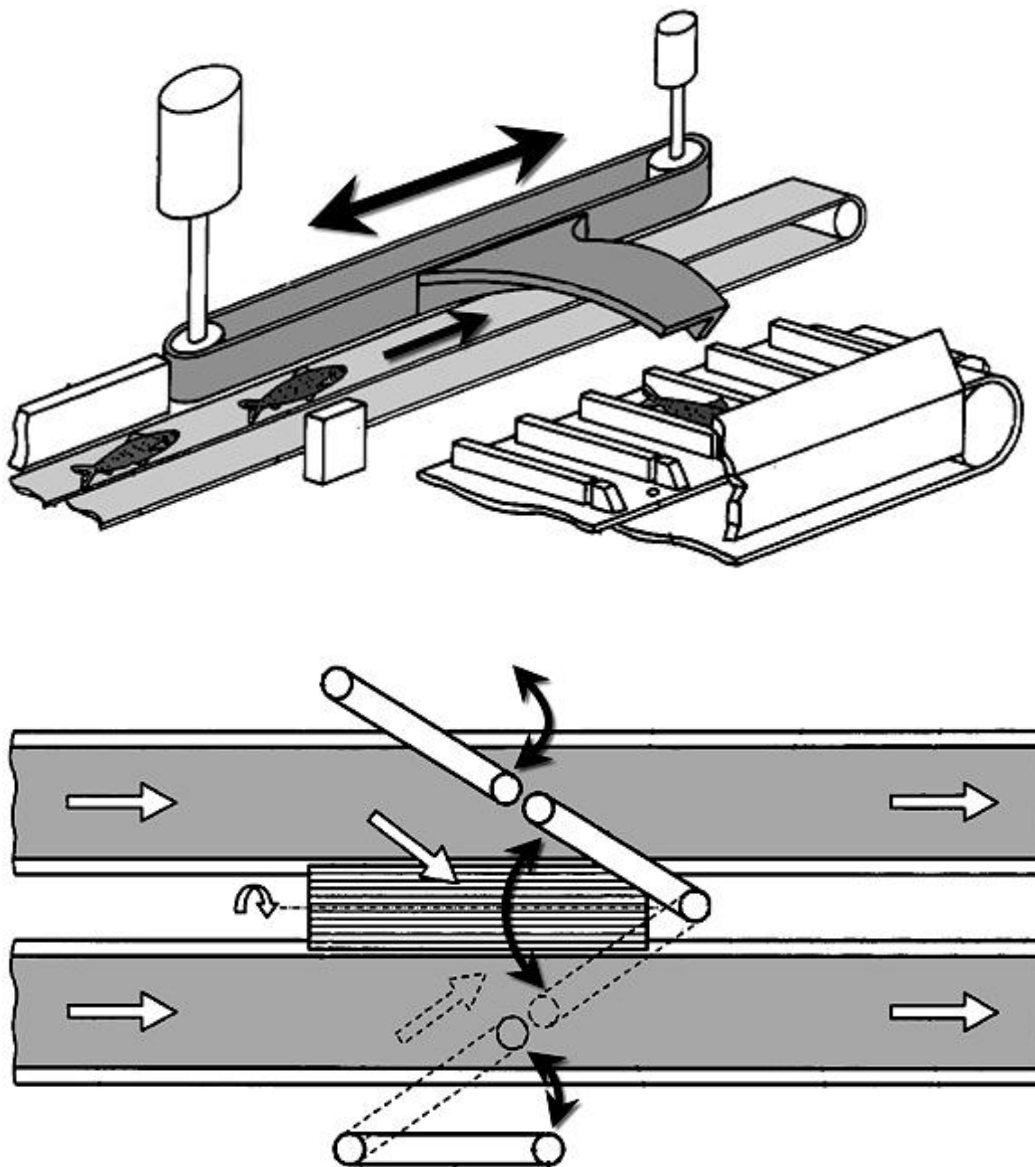



**B65G 47/78**

Troughs having discharge openings and closures {(in air-slides [B65G 53/20](#))}

**Definition statement**

*This place covers:*

Illustrative example of subject matter classified in this group:

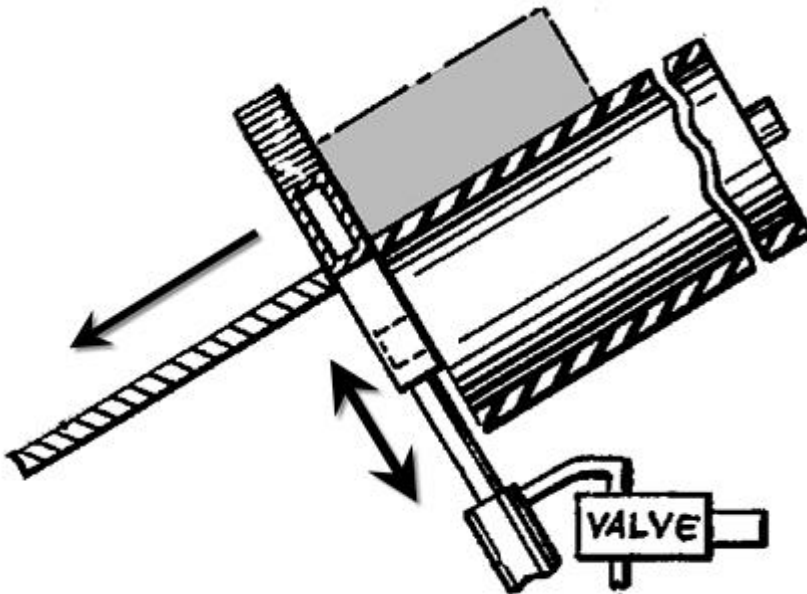
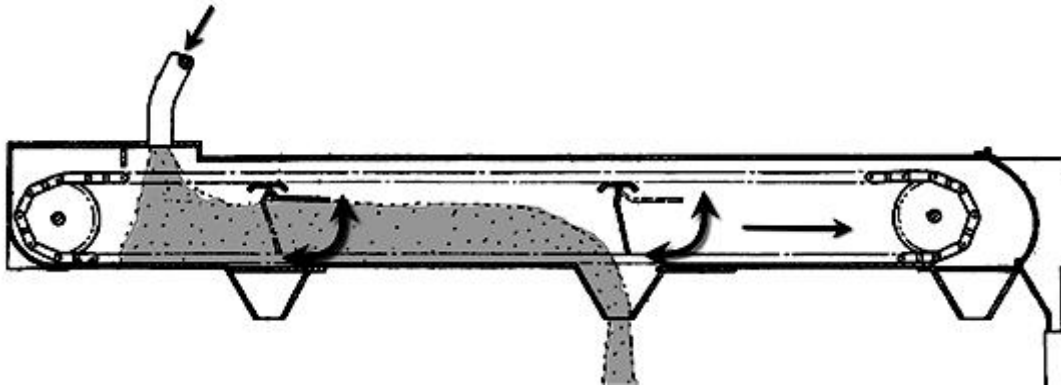
**References*****Informative references***

*Attention is drawn to the following places, which may be of interest for search:*

The discharge closure(s) is moving with the conveyor	<a href="#">B65G 47/38</a>
------------------------------------------------------	----------------------------

## B65G 47/80

**Turntables carrying articles or materials to be transferred, e.g. combined with ploughs or scrapers**

### Definition statement

*This place covers:*

Illustrative example of subject matter classified in this group:

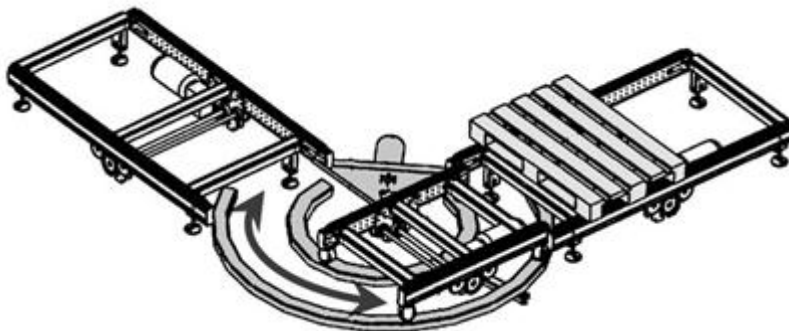
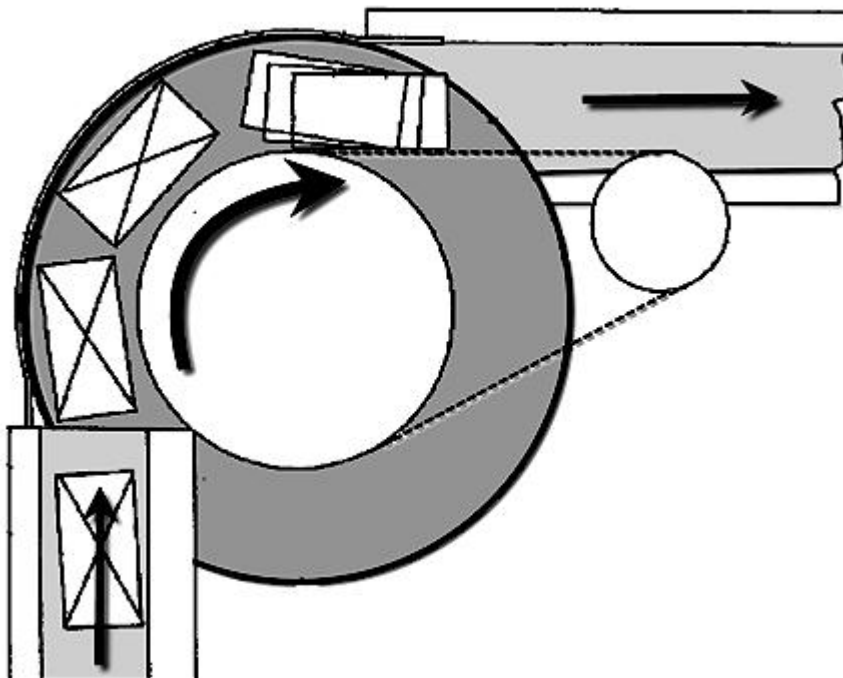

### References

#### Informative references

Attention is drawn to the following places, which may be of interest for search:

Construction of the turntable	<a href="#">B65G 29/00</a>
Rotating movement in the plane of the rotating part	<a href="#">B65G 47/1457</a>

## B65G 47/82

Rotary or reciprocating members for direct action on articles or materials, e.g. pushers, rakes, shovels {(means for pushing glass articles onto a conveyor [C03B 9/453](#))}

### Definition statement

*This place covers:*

Illustrative example of subject matter classified in this group:

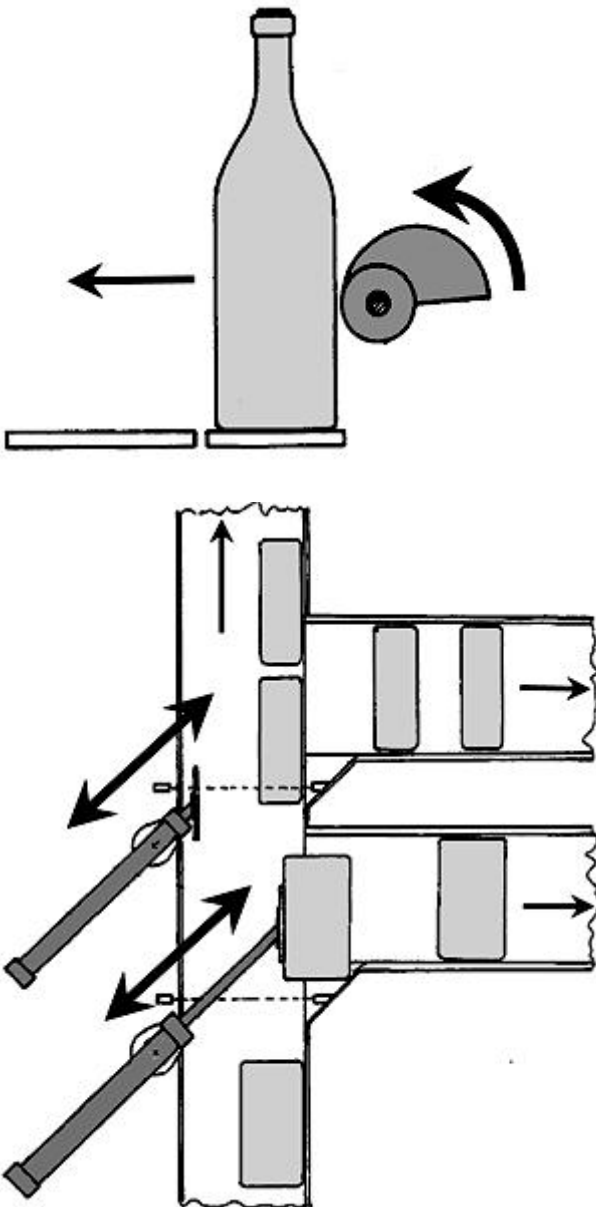

**B65G 47/841**

{Devices having endless travelling belts or chains equipped with article-engaging elements}

**Definition statement**

*This place covers:*

Illustrative example of subject matter classified in this group:

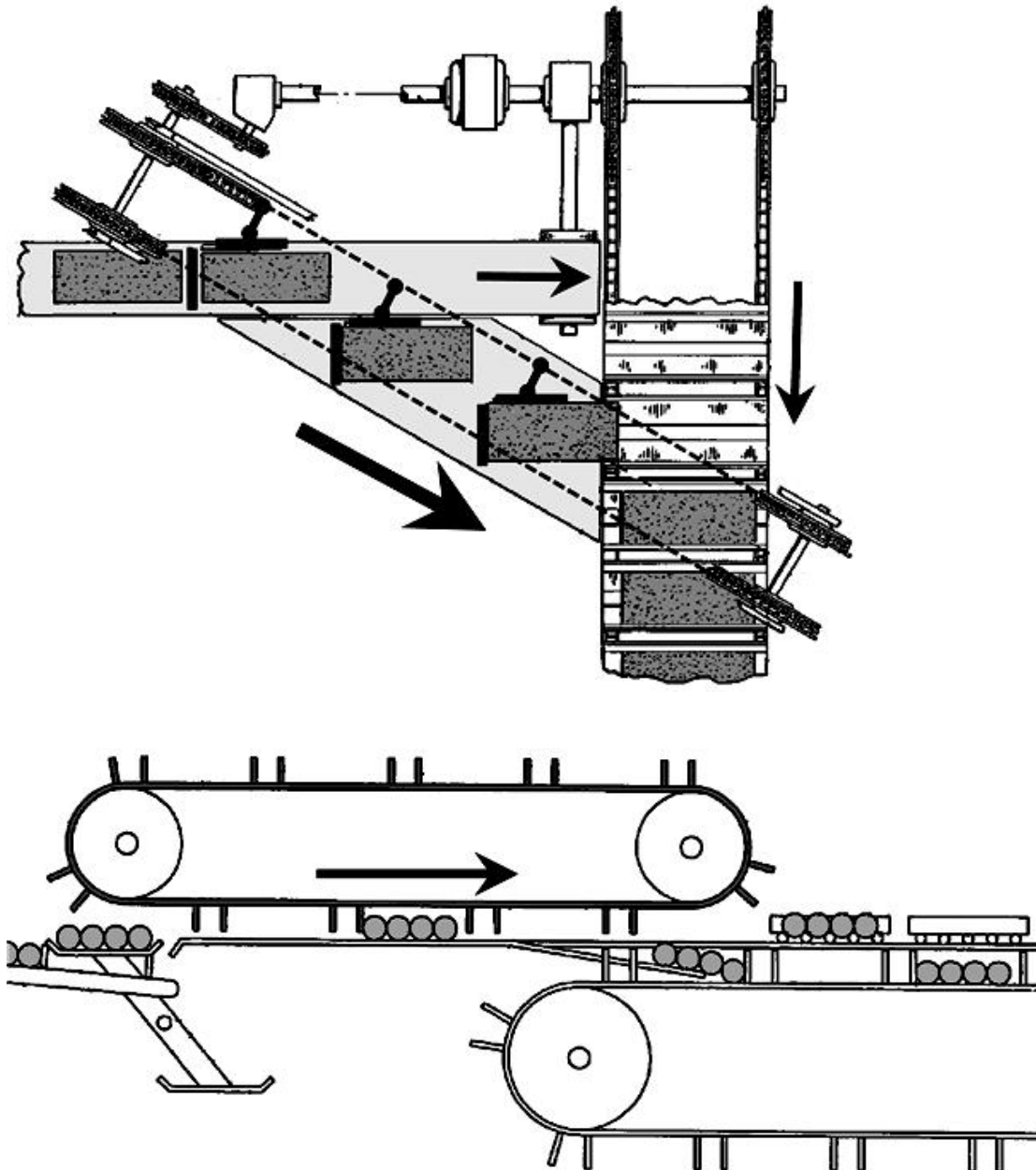
**References****Informative references**

Attention is drawn to the following places, which may be of interest for search:

Separating or stopping elements	<a href="#">B65G 47/88</a>
---------------------------------	----------------------------

## B65G 47/842

{the article-engaging elements being grippers}

### Definition statement

*This place covers:*

Illustrative example of subject matter classified in this group:

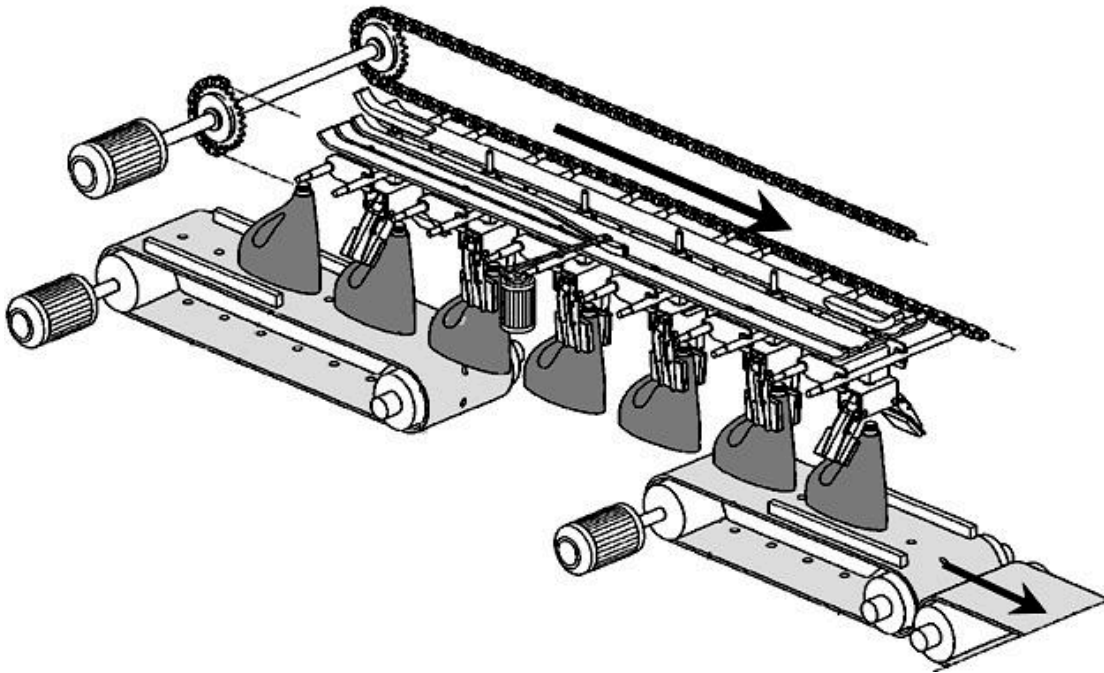

**B65G 47/843**

{the article-engaging elements being suction or magnetic means}

**Definition statement**

*This place covers:*

Illustrative example of subject matter classified in this group:

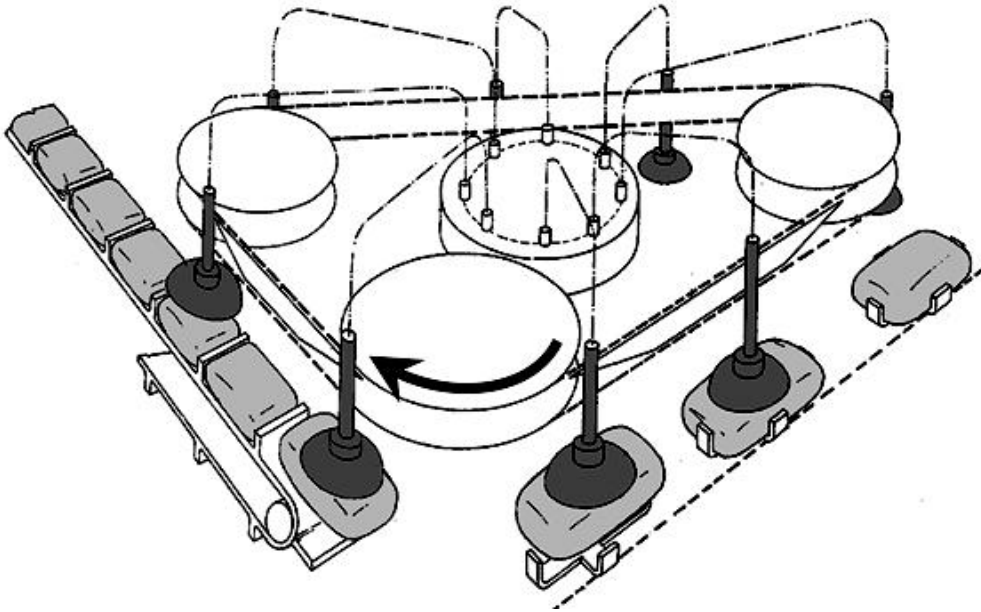
**B65G 47/844**

{the article-engaging elements being pushers transversally movable on the supporting surface, e.g. pusher-shoes}

**Definition statement**

*This place covers:*

Illustrative example of subject matter classified in this group:

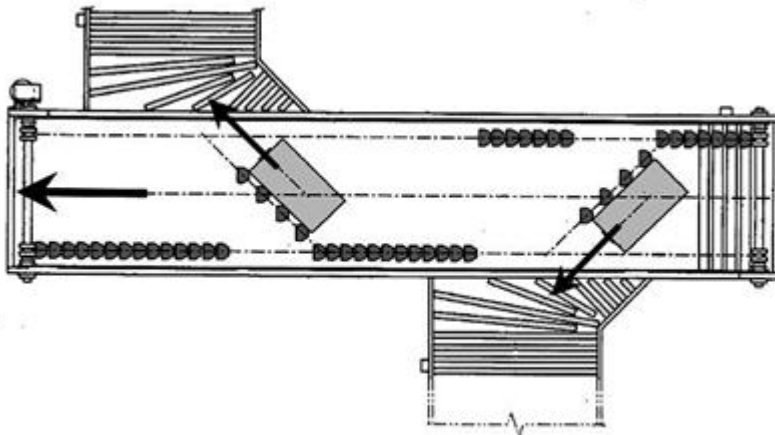



## References

### Informative references

Attention is drawn to the following places, which may be of interest for search:

The load-carrier is transversally movable	<a href="#">B65G 17/005</a>
-------------------------------------------	-----------------------------

## B65G 47/845

{the article engaging elements being pushers moving in parallel and independently from the supporting conveyor}

### Definition statement

*This place covers:*

Illustrative example of subject matter classified in this group:

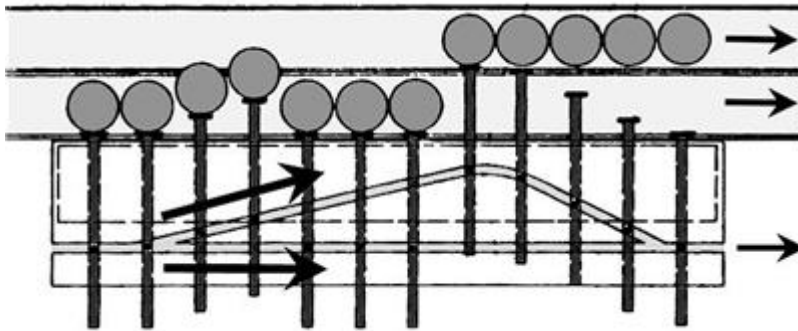

## B65G 47/846

{Star-shaped wheels or wheels equipped with article-engaging elements}

### Definition statement

*This place covers:*

Illustrative example of subject matter classified in this group:

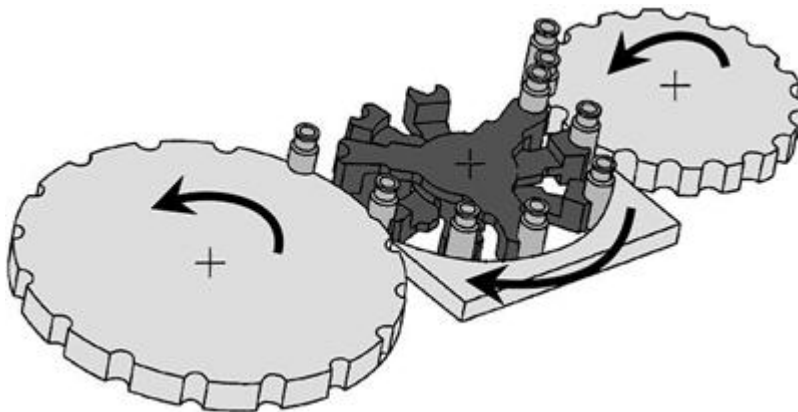

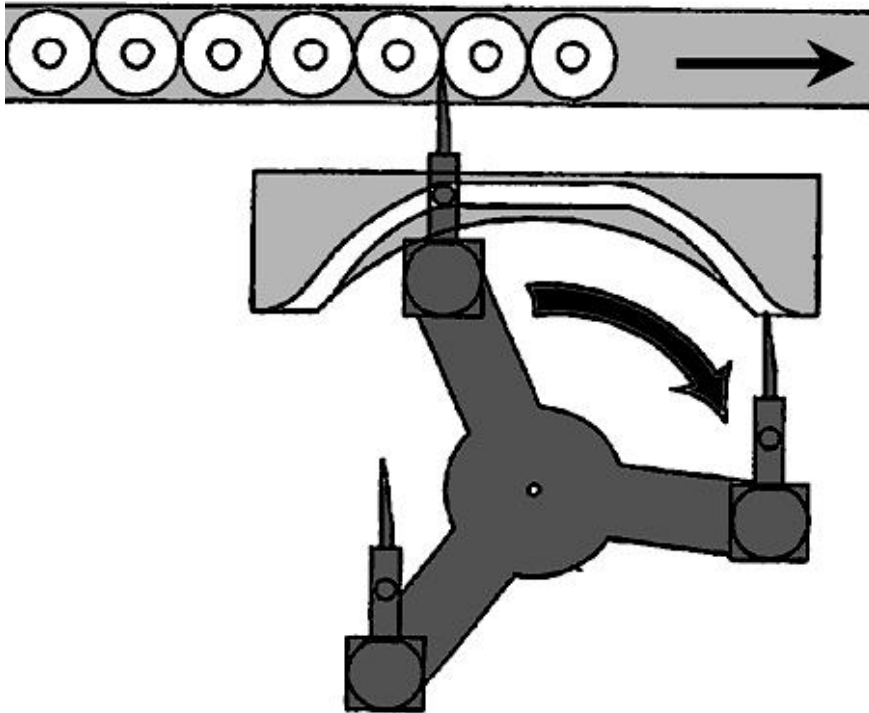

## References

### *Informative references*

*Attention is drawn to the following places, which may be of interest for search:*

Rotary conveyors	<a href="#">B65G 29/00</a>
Separating or stopping elements	<a href="#">B65G 47/88</a>
Bottles	<a href="#">B67C 7/004</a>



**B65G 47/847**

{the article-engaging elements being grippers}

**Definition statement**

*This place covers:*

Illustrative example of subject matter classified in this group:

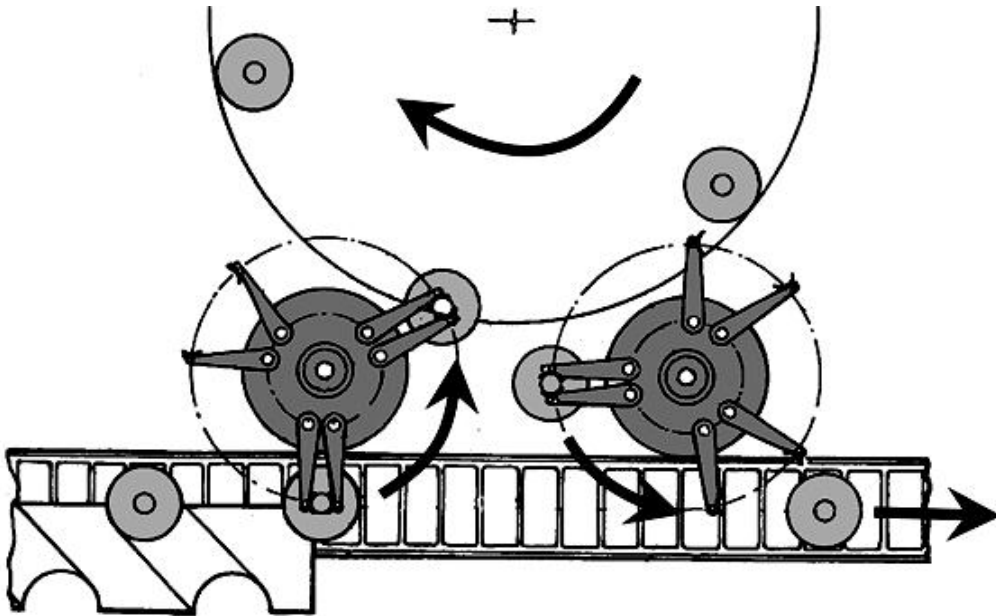
**References****Informative references**

*Attention is drawn to the following places, which may be of interest for search:*

Bottles	<a href="#">B67C 7/004</a>
Star-shaped wheels (FICLA)	B65G47/86&A
Revolving on horizontal plane (FICLA)	B65G47/86&B
Revolving on a vertical plane (FICLA)	B65G47/86&C

**B65G 47/848**

{the article-engaging elements being suction or magnetic means}

**Definition statement**

*This place covers:*

Illustrative example of subject matter classified in this group:

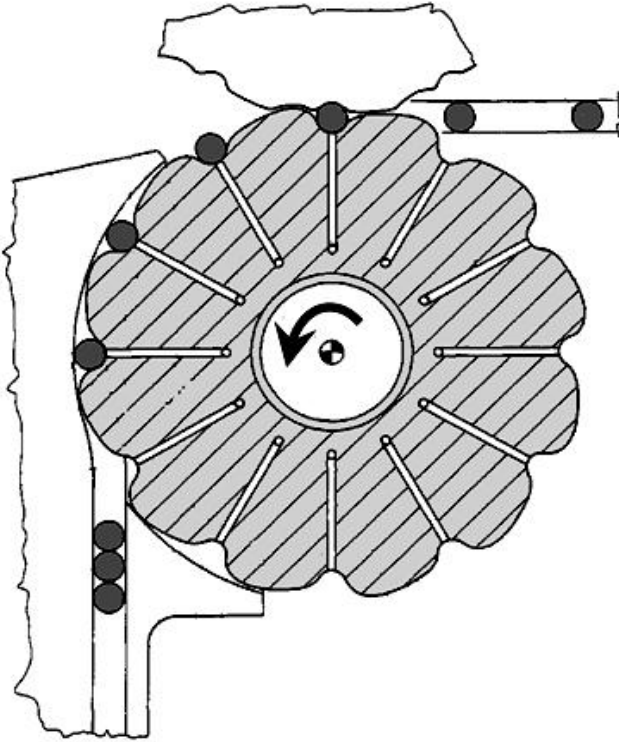
**References****Informative references**

*Attention is drawn to the following places, which may be of interest for search:*

Suction type grippers (FICLA)	B65G47/86&G
Suction type grippers (FICLA)	B65G47/86&H

**B65G 47/88**

**Separating or stopping elements, e.g. fingers (attached to star-shaped wheels [B65G 47/84](#))**

**Definition statement**

*This place covers:*

Illustrative example of subject matter classified in this group:

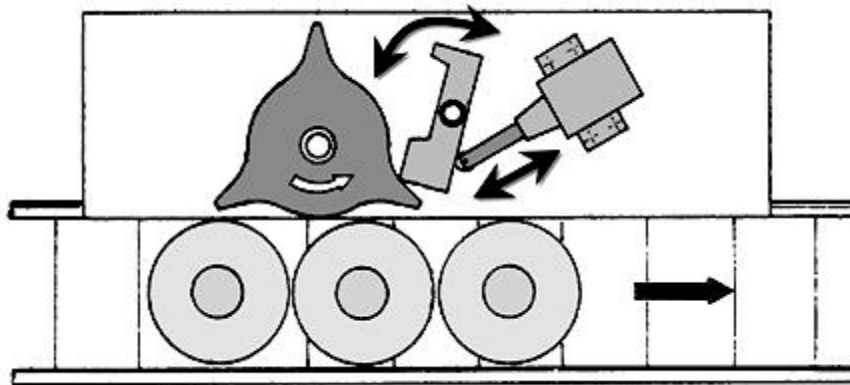
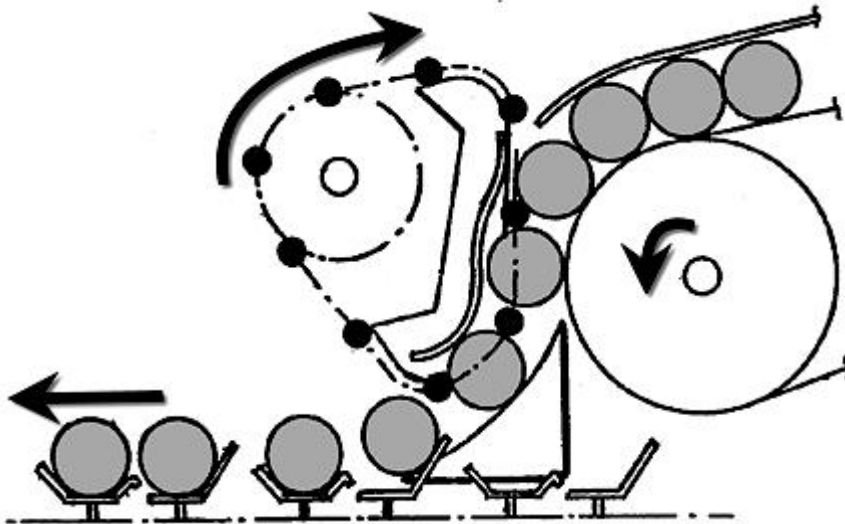
**References****Informative references**

Attention is drawn to the following places, which may be of interest for search:

By temporarily stopping movement	<a href="#">B65G 47/29</a>
Postal sorting; sorting individual articles, or bulk material fit to be sorted piece-meal	<a href="#">B07C</a>

**Special rules of classification**

Indexing Codes:

- [B65G 2205/00](#) Stops used in conveyors to stop articles or arrays of articles

- [B65G 2205/02](#) where the stop is adaptable to the size of the article or array
- [B65G 2205/04](#) where the stop is not adaptable
- [B65G 2205/06](#) cushioned or damping stops, e.g. using springs

## **B65G 47/8815**

**{Reciprocating stop, moving up or down in the path of the article}**

### **Definition statement**

*This place covers:*

Illustrative example of subject matter classified in this group:

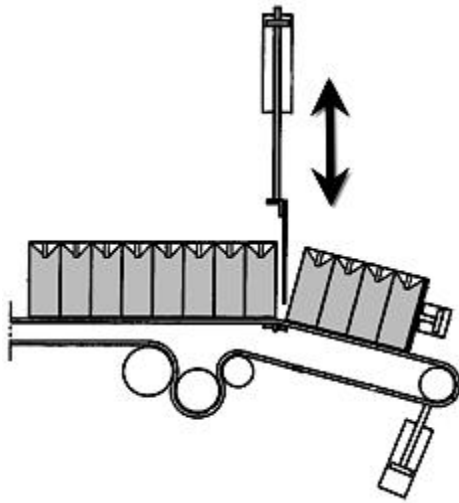

## **B65G 47/8823**

**{Pivoting stop, swinging in or out of the path of the article}**

### **Definition statement**

*This place covers:*

Illustrative example of subject matter classified in this group:

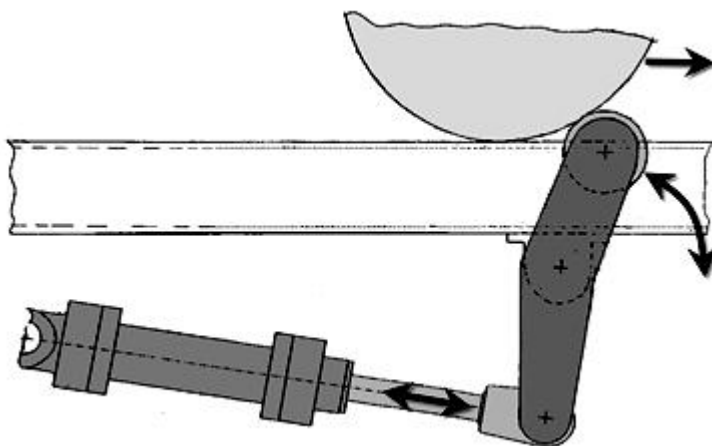

## B65G 47/883

{Fixed stop}

### Definition statement

*This place covers:*

Only not-moving stop

Illustrative example of subject matter classified in this group:

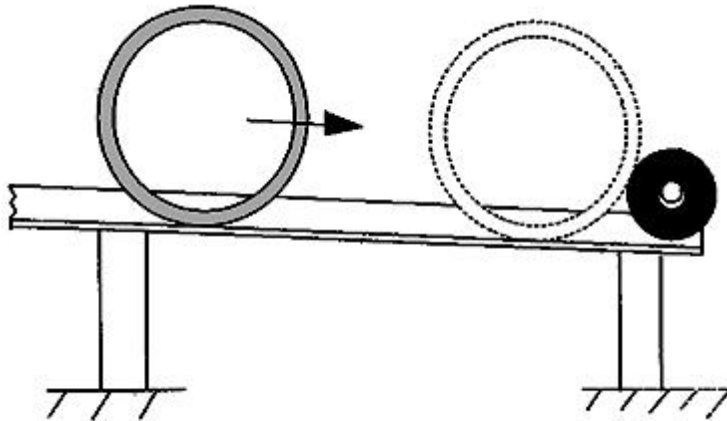

### References

#### Limiting references

*This place does not cover:*

Moving stop	<a href="#">B65G 47/88</a>
-------------	----------------------------

### B65G 47/8838

{with a linearly movable pusher element which lifts or releases the article}

#### Definition statement

*This place covers:*

Illustrative example of subject matter classified in this group:

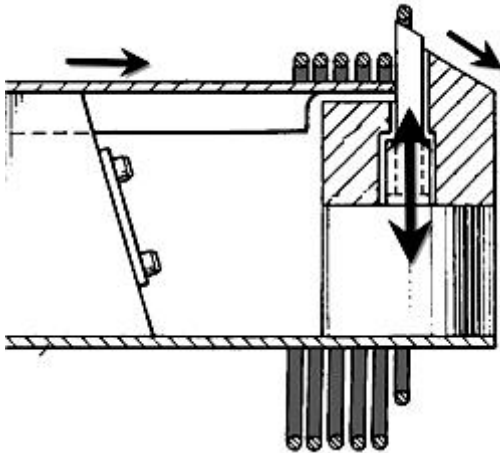

### B65G 47/8846

{with a pivoting pusher element which lifts or releases the article}

#### Definition statement

*This place covers:*

Illustrative example of subject matter classified in this group:

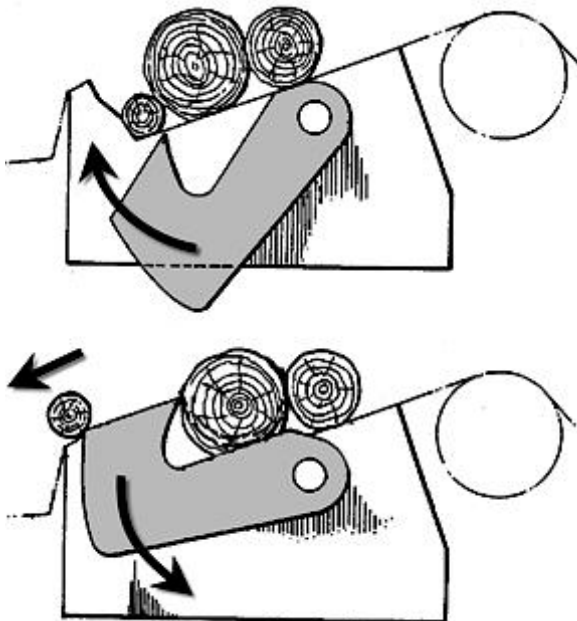

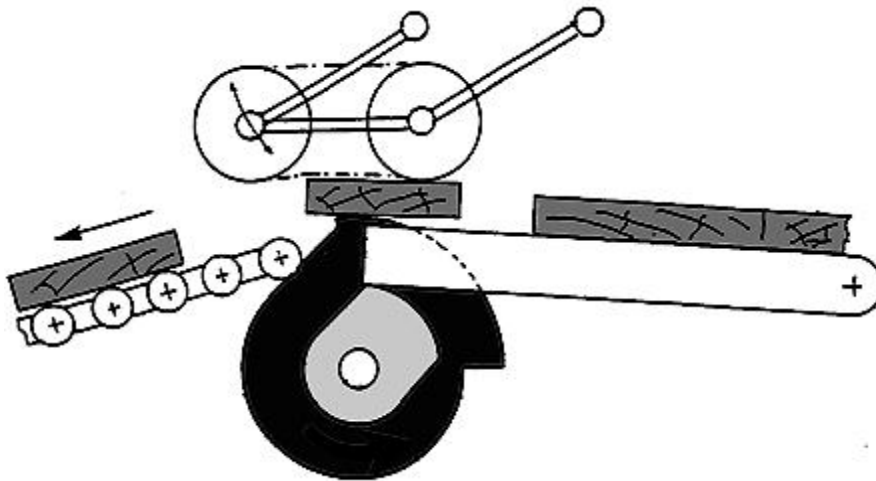

## References

### Limiting references

*This place does not cover:*

Pivoting conveyors	<a href="#">B65G 47/8853</a>
--------------------	------------------------------

## B65G 47/8853

{with conveyors, e.g. pivoting or rotating, to transfer the article}

### Definition statement

*This place covers:*

Illustrative example of subject matter classified in this group:

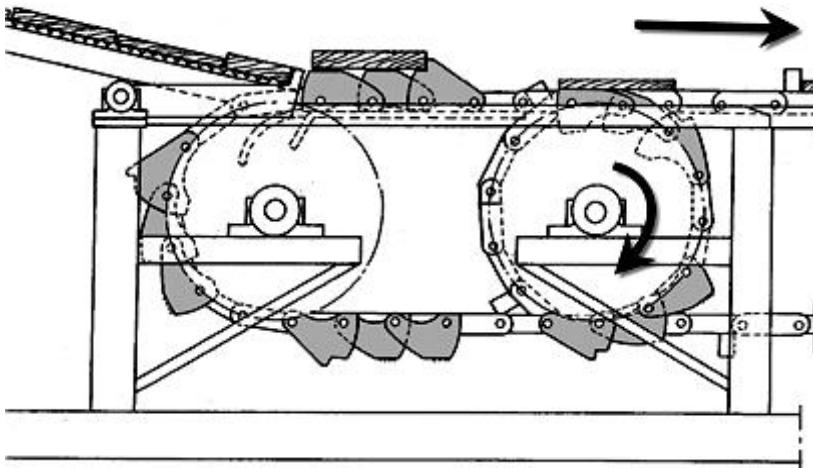

## References

### Limiting references

*This place does not cover:*

Starwheels	<a href="#">B65G 47/88</a>
------------	----------------------------

## B65G 47/8861

{Stop in the form of a clamp on one or both sides of the article}

### Definition statement

*This place covers:*

Illustrative example of subject matter classified in this group:

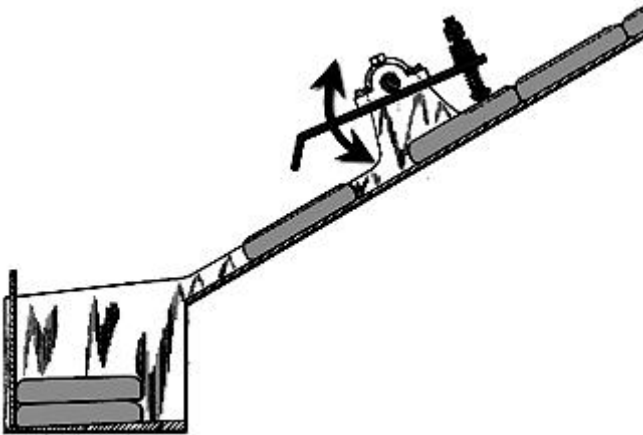

## B65G 47/8869

{stopping or lifting all articles from a conveyor}

### Definition statement

*This place covers:*

Illustrative example of subject matter classified in this group:

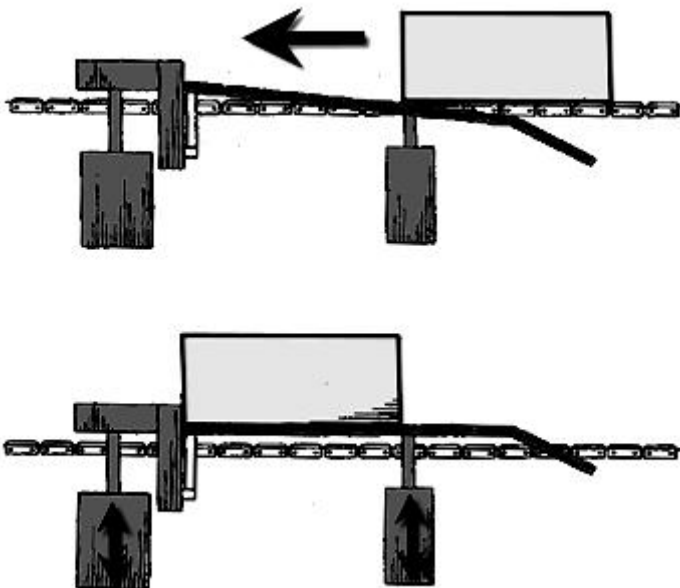



**B65G 47/8876**

{with at least two stops acting as gates}

**Definition statement**

*This place covers:*

Synchronously acting stops

Illustrative example of subject matter classified in this group:

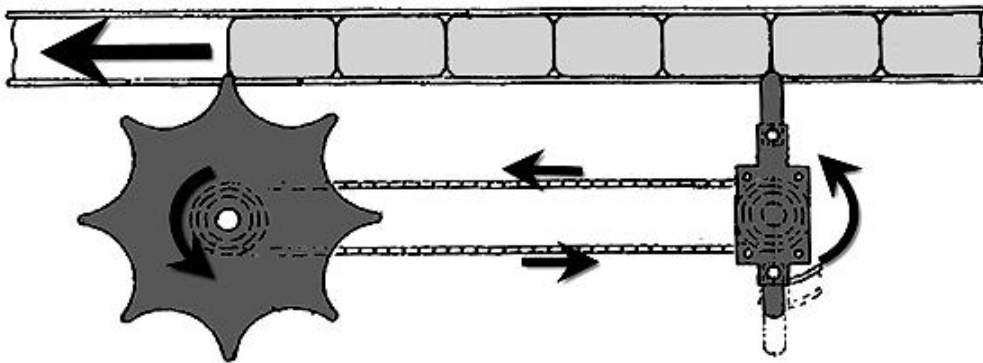
**B65G 47/8884**

{Stops acting asynchronously, e.g. one stop open, next one closed or the opposite}

**Definition statement**

*This place covers:*

Illustrative example of subject matter classified in this group:

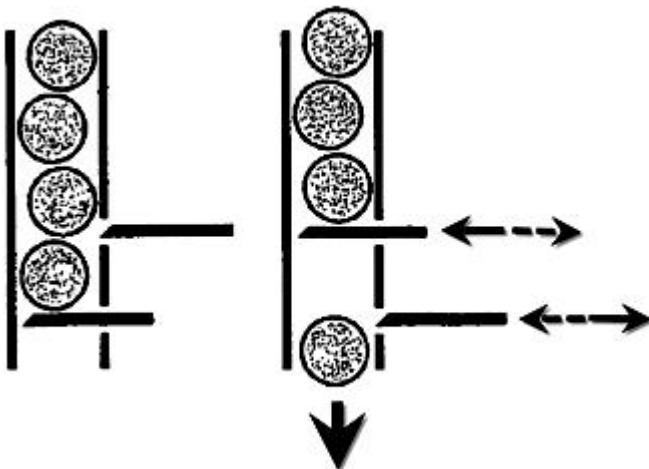

## References

### *Informative references*

Attention is drawn to the following places, which may be of interest for search:

The articles being fed by gravity	<a href="#">B65G 1/08</a>
-----------------------------------	---------------------------

## B65G 47/8892

{Stops acting independently of each other}

### Definition statement

*This place covers:*

Illustrative example of subject matter classified in this group:

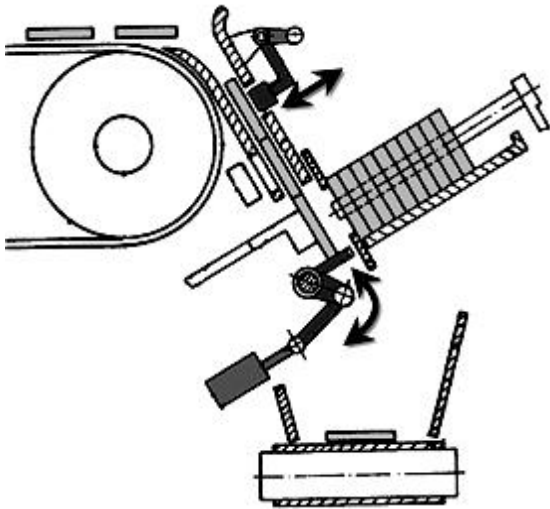

**B65G 47/90****Devices for picking-up and depositing articles or materials****Definition statement**

*This place covers:*

Illustrative example of subject matter classified in this group:

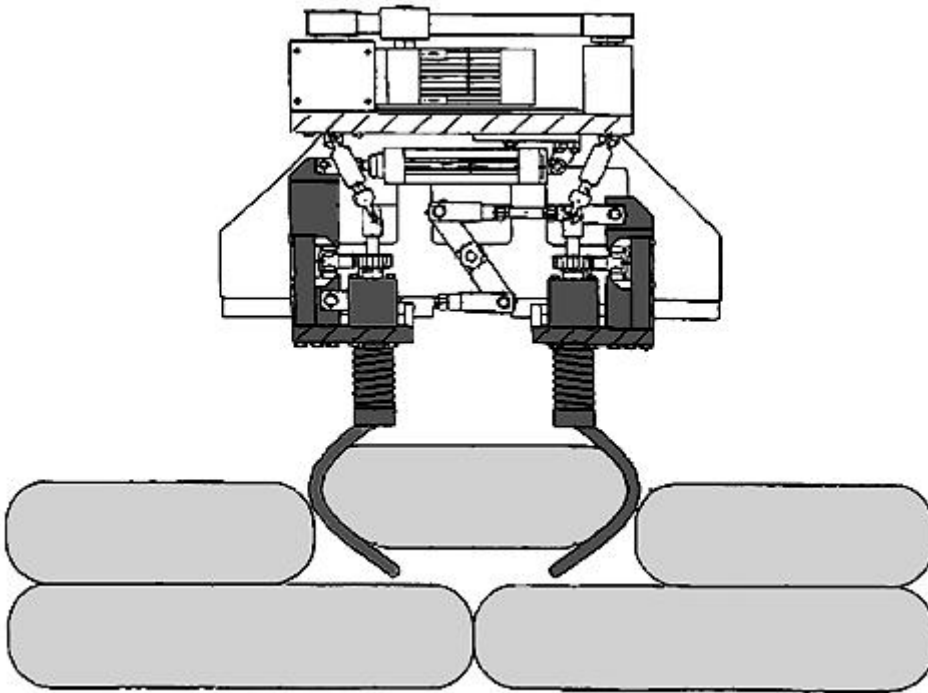
**References****Limiting references**

*This place does not cover:*

Combination of suction and mechanical grippers	<a href="#">B65G 47/90</a> , <a href="#">B65G 47/91</a>
------------------------------------------------	---------------------------------------------------------

**Informative references**

*Attention is drawn to the following places, which may be of interest for search:*

Arrangements for handling work specially combined with or arranged in, or specially adapted for use in connection with, machine tools	<a href="#">B23Q 7/00</a>
Gripping means	<a href="#">B25J 15/00</a>

**B65G 47/901**

**{provided with drive systems with rectilinear movements only}**

**Definition statement**

*This place covers:*

Drive system for the whole gripper (not for the gripping "fingers")

Illustrative example of subject matter classified in this group:

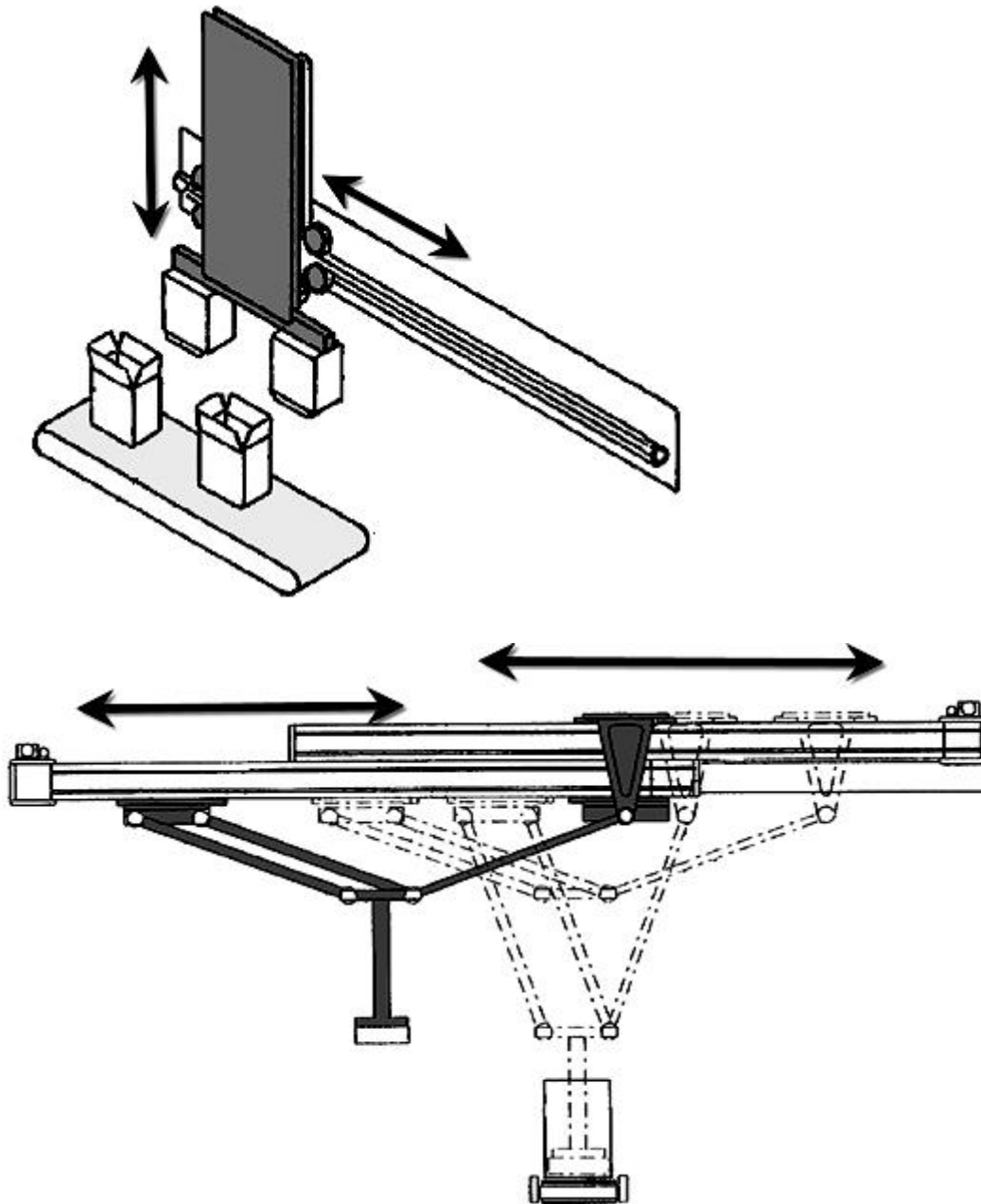

## References

### *Informative references*

Attention is drawn to the following places, which may be of interest for search:

Incorporating pneumatic, e.g. suction, grippers	<a href="#">B65G 47/91</a>
-------------------------------------------------	----------------------------

**B65G 47/902**

{provided with drive systems incorporating rotary and rectilinear movements}

**Definition statement**

*This place covers:*

Drive system for the whole gripper (not for the gripping "fingers")

Illustrative example of subject matter classified in this group:

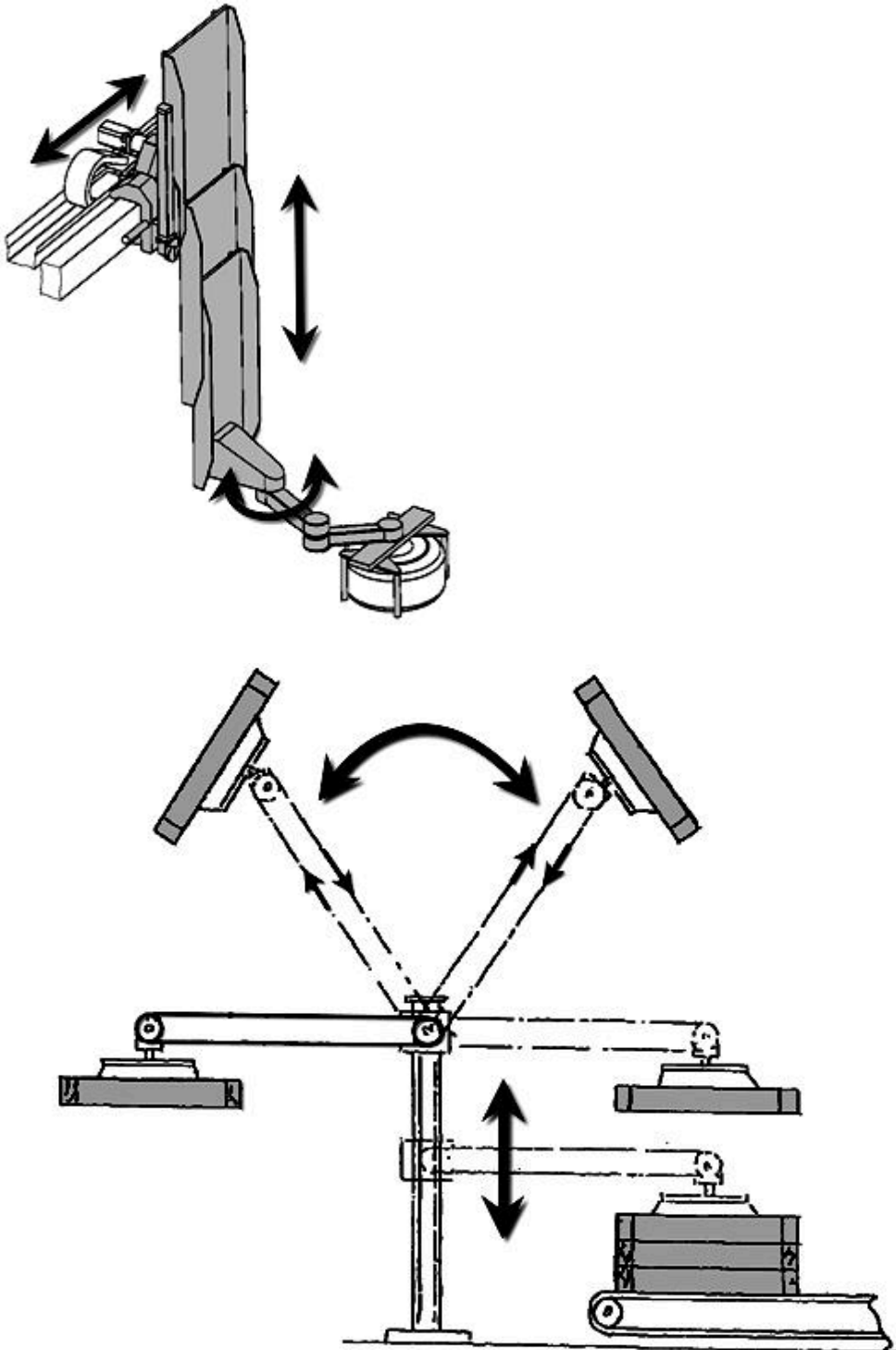

## References

### Informative references

Attention is drawn to the following places, which may be of interest for search:

Incorporating pneumatic provided with drive systems incorporating rotary and rectilinear movements	<a href="#">B65G 47/914</a>
----------------------------------------------------------------------------------------------------	-----------------------------

## B65G 47/904

{provided with rotary movements only}

### Definition statement

*This place covers:*

Drive system for the whole gripper (not for the gripping "fingers")

Illustrative example of subject matter classified in this group:

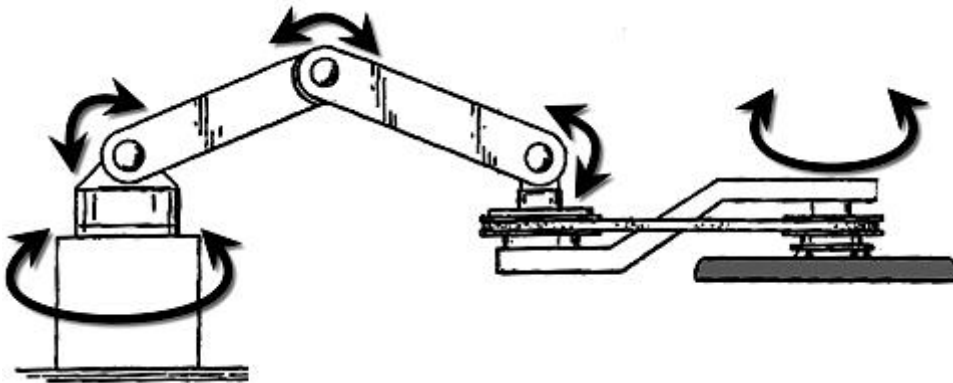

## References

### Informative references

Attention is drawn to the following places, which may be of interest for search:

Incorporating pneumatic provided with drive systems with rotary movements only	<a href="#">B65G 47/915</a>
--------------------------------------------------------------------------------	-----------------------------

## B65G 47/905

{Control arrangements}

### Definition statement

*This place covers:*

Illustrative example of subject matter classified in this group:

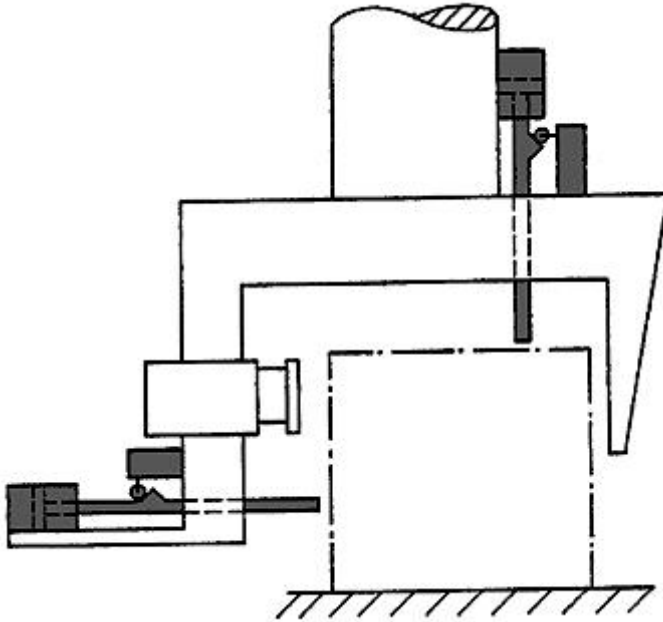

## B65G 47/907

{with at least two picking-up heads}

### Definition statement

*This place covers:*

Grippers working together or independently

Illustrative example of subject matter classified in this group:

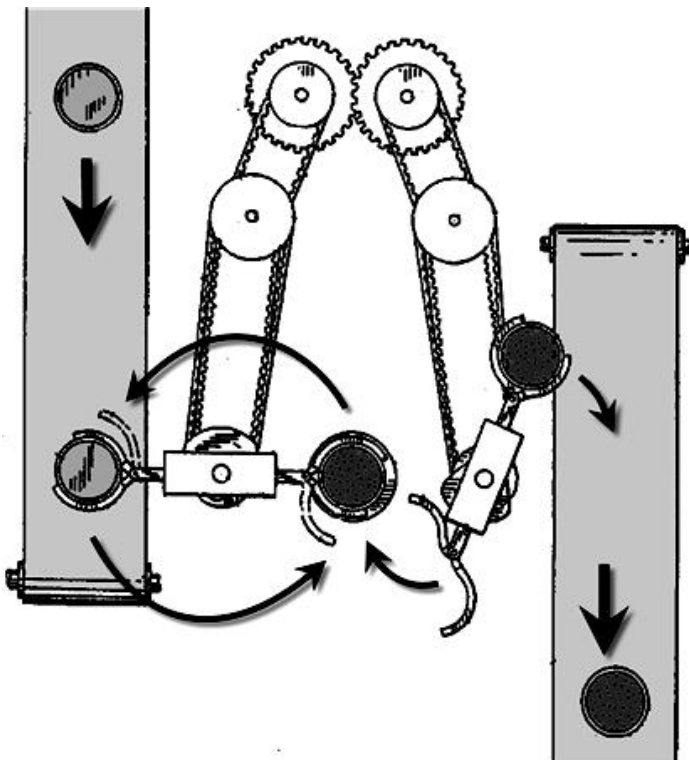
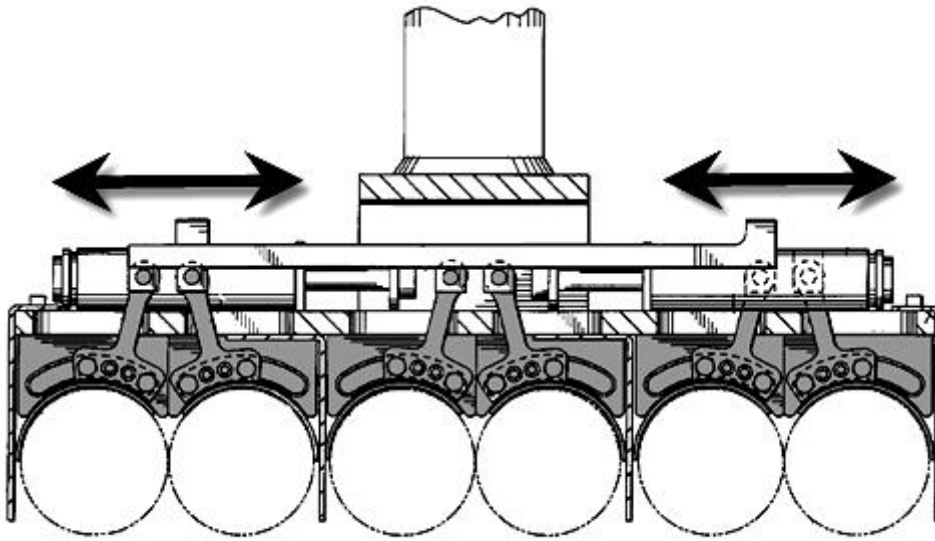

## References

### *Informative references*

*Attention is drawn to the following places, which may be of interest for search:*

Incorporating pneumatic with at least two picking-up heads	<a href="#">B65G 47/918</a>
------------------------------------------------------------	-----------------------------



## B65G 47/908

{with inflatable picking-up means (inflatable gripping members on load engaging elements for cranes [B66C 1/46](#))}

### Definition statement

*This place covers:*

Illustrative example of subject matter classified in this group:

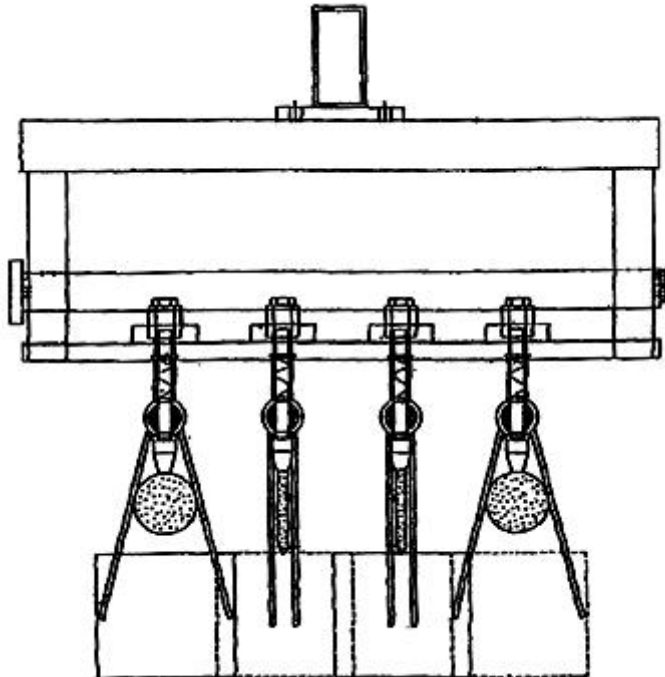
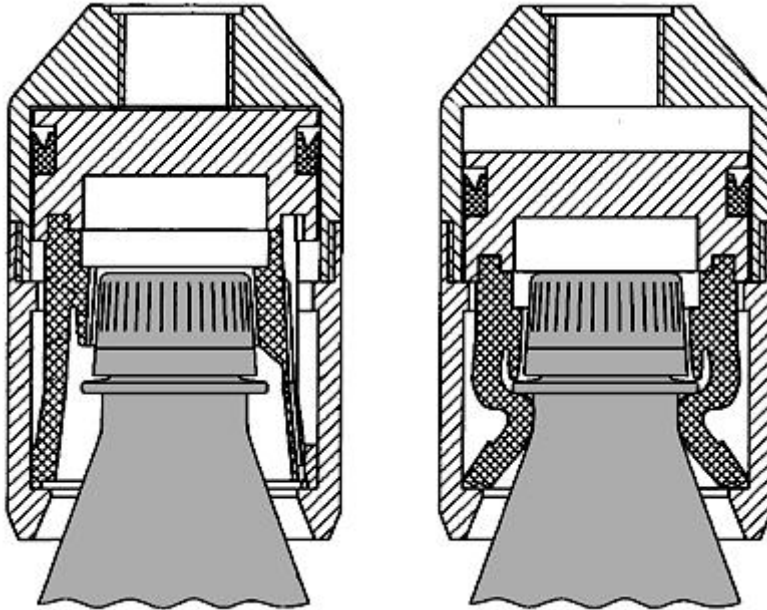

## References

### Informative references

Attention is drawn to the following places, which may be of interest for search:

Inflatable gripping members on load engaging elements for cranes	<a href="#">B66C 1/46</a>
------------------------------------------------------------------	---------------------------

## B65G 47/91

incorporating pneumatic, e.g. suction, grippers

### Definition statement

This place covers:

Illustrative example of subject matter classified in this group:

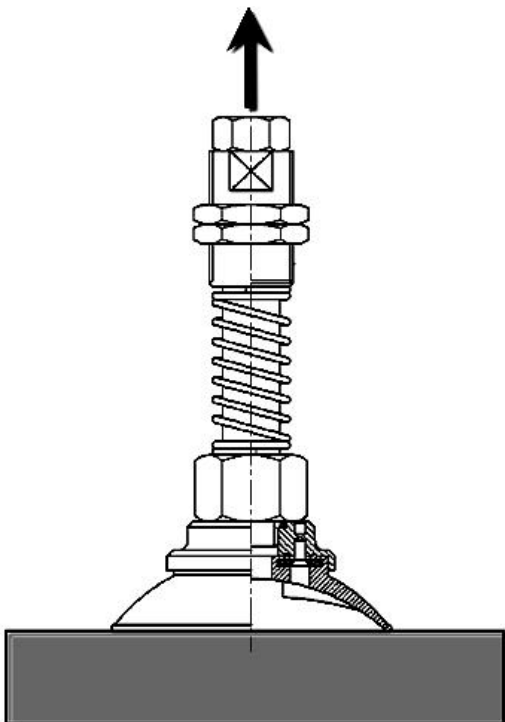
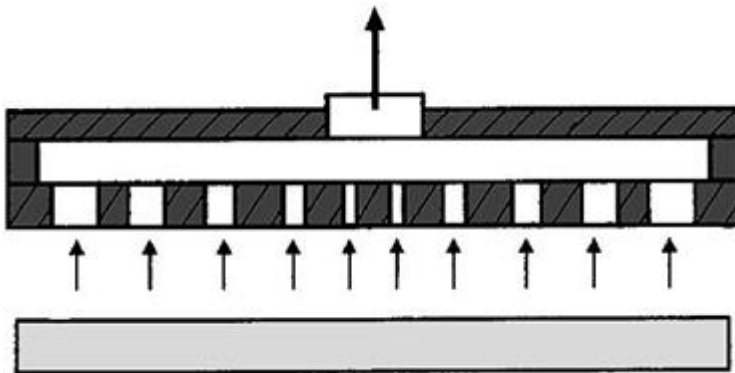

## References

### Informative references

Attention is drawn to the following places, which may be of interest for search:

Combination of suction and mechanical grippers	<a href="#">B65G 47/90</a> , <a href="#">B65G 47/91</a>
Lifting, gripping, or carrying mans, for one or more sheets forming independent means of transport	<a href="#">B65G 49/061</a>
Vacuum work holders	<a href="#">B25B 11/005</a>
Gripping heads with vacuum	<a href="#">B25J 15/0616</a>
Load-engaging elements or devices by suction means	<a href="#">B66C 1/02</a>
Purposes of adsrption devices (FTCLA)	3C007/FU05
Valves (FTCLA)	3C007/FU06

## B65G 47/911

{with air blasts producing partial vacuum}

### Definition statement

*This place covers:*

Here for example a Bernoulli effect is achieved nearby the object (air is blown near/towards/directly on the object).

Also "partial vacuum" means that generally there is partial/no contact between the object and teh gripper.

This sub-group is NOT to be used if the Bernoulli effect is achieved far away from the object - then [B65G 47/91](#) is to be used.

Illustrative example of subject matter classified in this group:

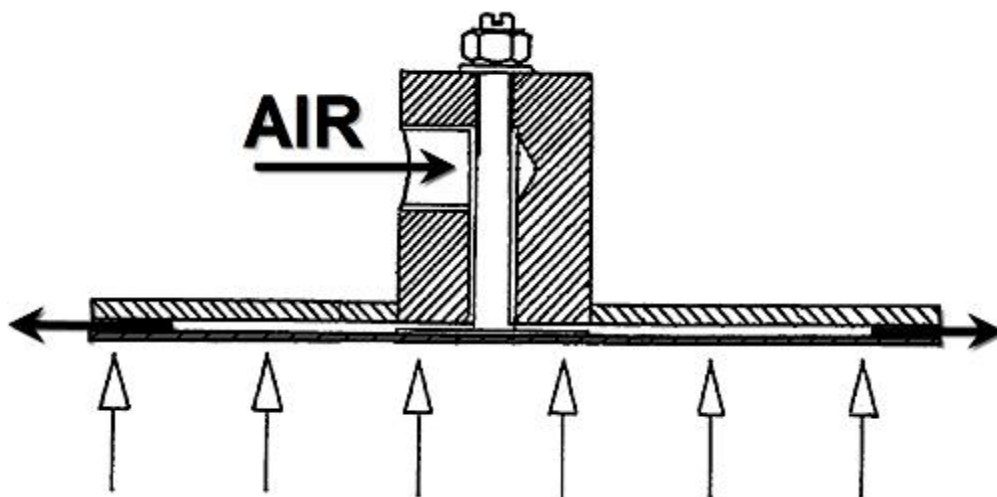

## References

### Informative references

Attention is drawn to the following places, which may be of interest for search:

Bernoulli devices	<a href="#">H01L 21/6838</a>
-------------------	------------------------------

## B65G 47/912

{provided with drive systems with rectilinear movements only}

### Definition statement

*This place covers:*

Relates only to how we bring the pick and place device (gripper) to the pick location (target object) and to the place location (final drop destination).

The movements of the arms carrying the gripper, associated columns etc have to be along straight line paths.

Illustrative example of subject matter classified in this group:

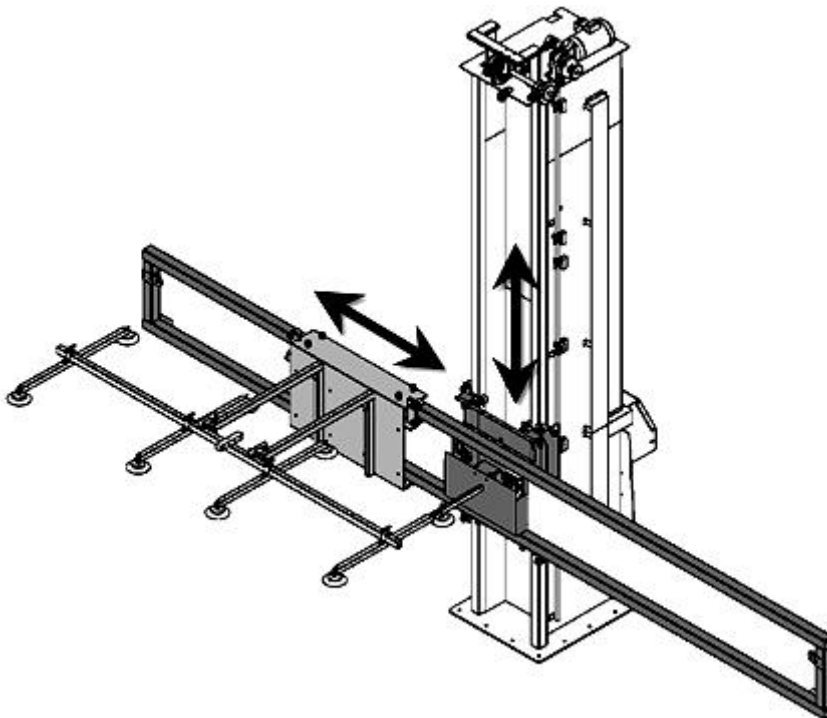

## References

### Informative references

Attention is drawn to the following places, which may be of interest for search:

Devices for picking-up and depositing articles or materials provided with drive systems with rectilinear movements only	<a href="#">B65G 47/901</a>
-------------------------------------------------------------------------------------------------------------------------	-----------------------------

**B65G 47/914****{provided with drive systems incorporating rotary and rectilinear movements}****Definition statement***This place covers:*

Relates only to how we bring the pick and place device (gripper) to the pick location (target object) and to the place location (final drop destination).

The movements of the arms carrying the gripper, associated columns etc are along rotary and straight line paths.

Illustrative example of subject matter classified in this group:

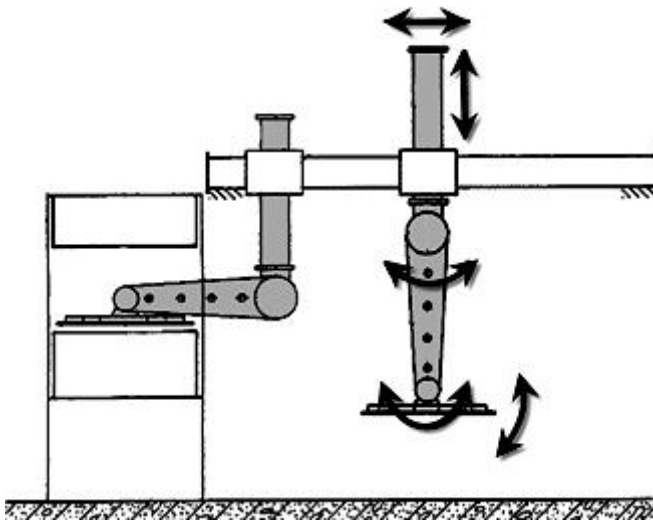
**References****Informative references**

Attention is drawn to the following places, which may be of interest for search:

Devices for picking-up and depositing articles or materials provided with drive systems incorporating rotary and rectilinear movements only	<a href="#">B65G 47/902</a>
---------------------------------------------------------------------------------------------------------------------------------------------	-----------------------------

**B65G 47/915****{provided with drive systems with rotary movements only}****Definition statement***This place covers:*

Relates only to how we bring the pick and place device (gripper) to the pick location (target object) and to the place location (final drop destination).

The movements of the arms carrying the gripper, associated columns etc are along only rotary paths.

Illustrative example of subject matter classified in this group:

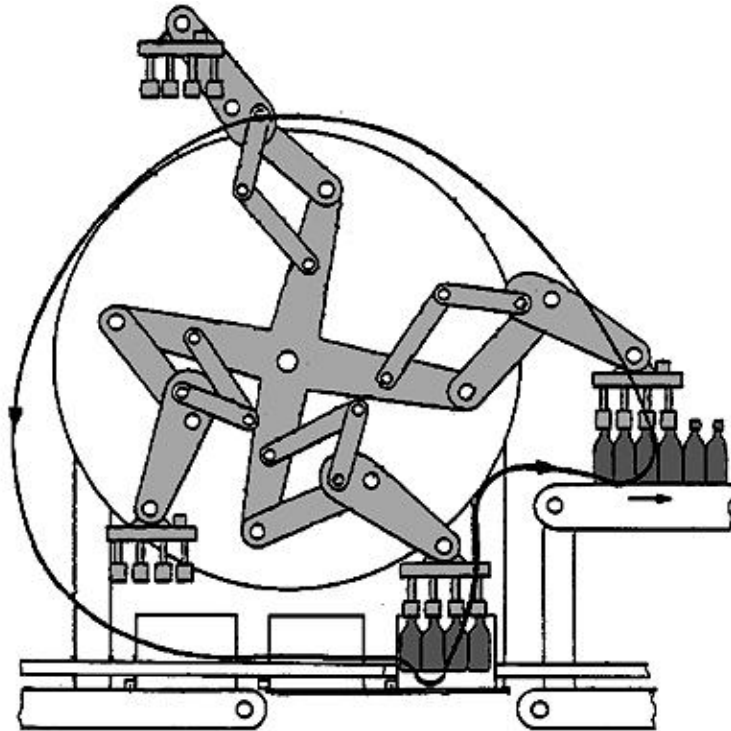

## References

### *Informative references*

*Attention is drawn to the following places, which may be of interest for search:*

Devices for picking-up and depositing articles or materials	<a href="#">B65G 47/90</a>
-------------------------------------------------------------	----------------------------

**B65G 47/917****{control arrangements}****Definition statement***This place covers:*

Illustrative example of subject matter classified in this group:

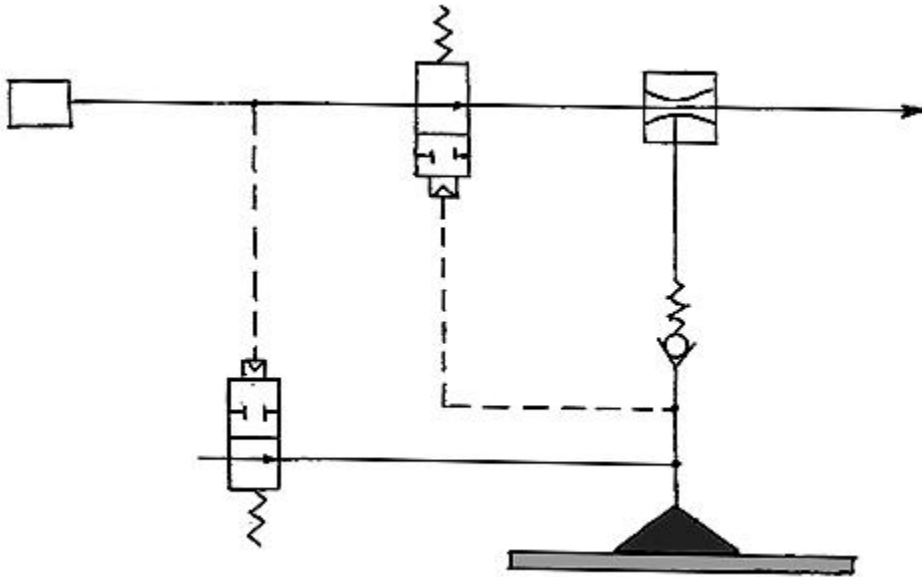
**B65G 47/918****{with at least two picking-up heads}****Definition statement***This place covers:*

Illustrative example of subject matter classified in this group:

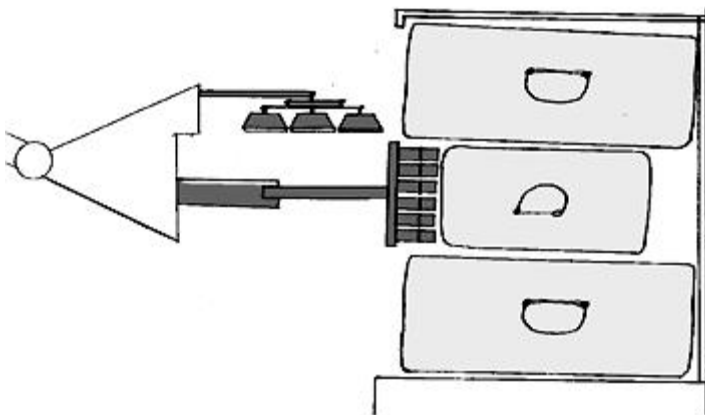

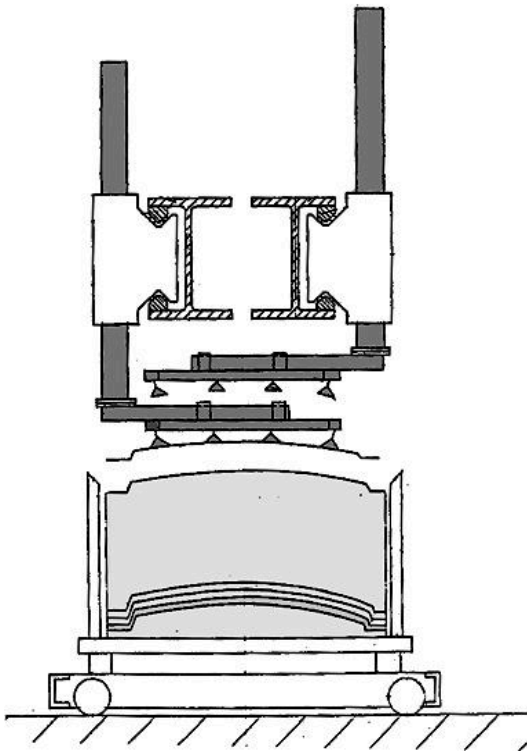

## References

### *Informative references*

*Attention is drawn to the following places, which may be of interest for search:*

Control arrangements	<a href="#">B65G 47/907</a>
----------------------	-----------------------------



**B65G 47/92****incorporating electrostatic or magnetic grippers****Definition statement***This place covers:*

Illustrative example of subject matter classified in this group:

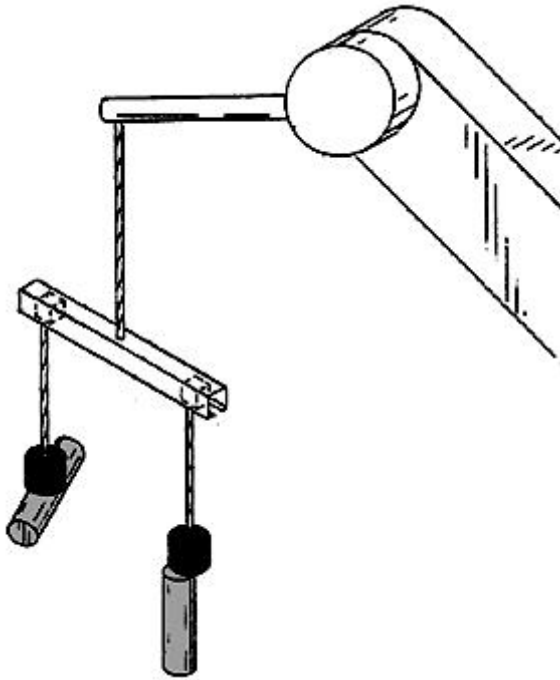
**References****Informative references***Attention is drawn to the following places, which may be of interest for search:*

Load-engaging elements or devices attached to lifting or lowering gear of cranes	<a href="#">B66C 1/04</a> , <a href="#">B66C 1/06</a>
----------------------------------------------------------------------------------	-------------------------------------------------------

**B65G 47/94****Devices for flexing or tilting travelling structures; Throw-off carriages****Definition statement***This place covers:*

Only endless surfaces

Illustrative example of subject matter classified in this group:

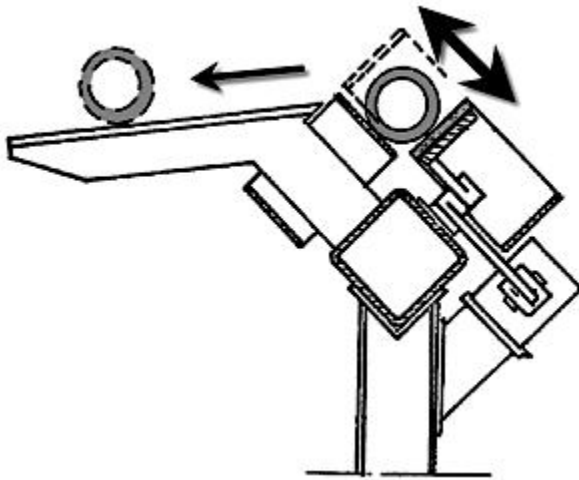

## References

### Limiting references

*This place does not cover:*

Non endless surfaces	<a href="#">B65G 47/96+</a>
----------------------	-----------------------------

## B65G 47/945

{tilting endless surfaces, e.g. belts}

### Definition statement

*This place covers:*

Only endless surfaces

Illustrative example of subject matter classified in this group:

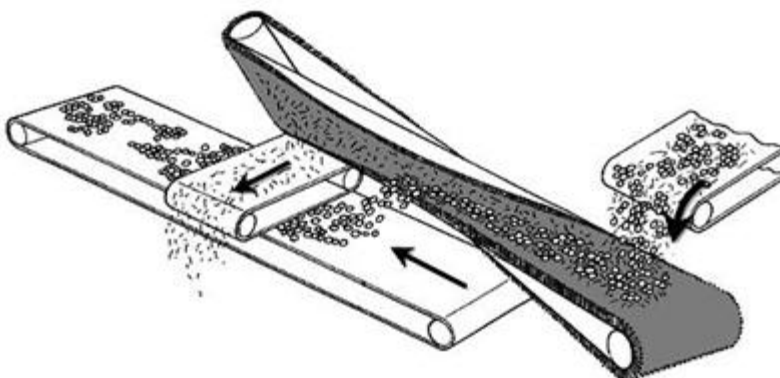

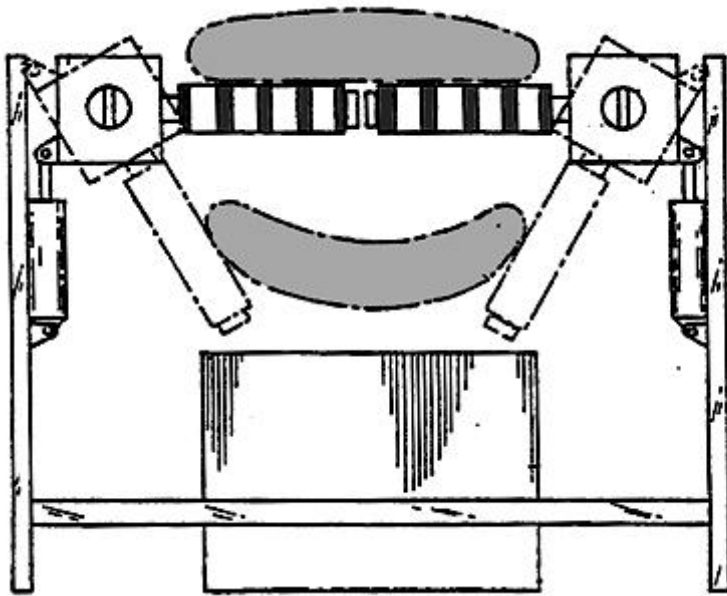

**References**

**Limiting references**

*This place does not cover:*

Non endless surfaces	<a href="#">B65G 47/96+</a>
----------------------	-----------------------------

**B65G 47/95**

adapted for longitudinal delivery

**Definition statement**

*This place covers:*

Illustrative example of subject matter classified in this group:

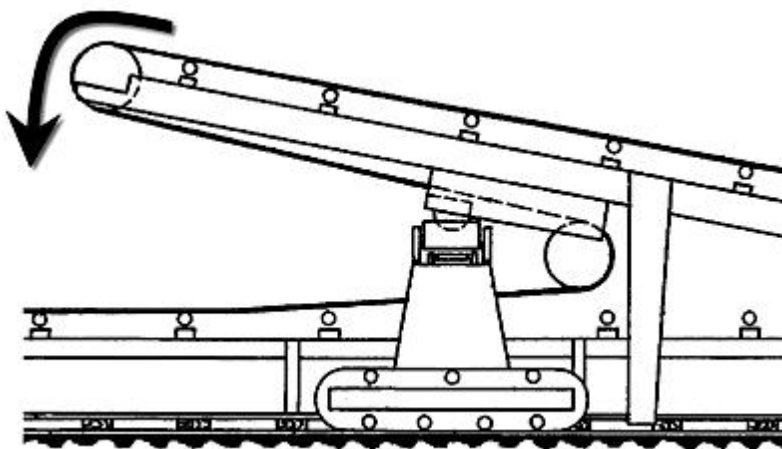

## References

### Informative references

Attention is drawn to the following places, which may be of interest for search:

Arrangements for supporting or guiding belts	<a href="#">B65G 15/60</a>
Devices for tilting links or platform	<a href="#">B65G 47/967</a>

## B65G 47/96

Devices for tilting links or platform {(releasing load-carriers [B65G 47/38](#))}

### Definition statement

This place covers:

Illustrative example of subject matter classified in this group:

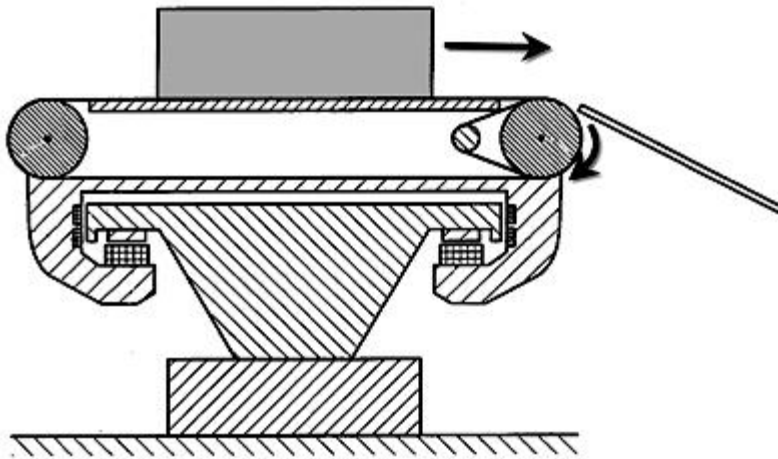

## References

### Informative references

Attention is drawn to the following places, which may be of interest for search:

The surfaces being equipped with a conveyors	<a href="#">B65G 17/345</a>
Cross-belt conveyor, tilt trays	<a href="#">B65G 47/962</a> , <a href="#">B65G 47/965</a>
Operation of carriers (FTCLA)	3F015/DA01

**B65G 47/962**

{tilting about an axis substantially parallel to the conveying direction}

**Definition statement**

*This place covers:*

Illustrative example of subject matter classified in this group:

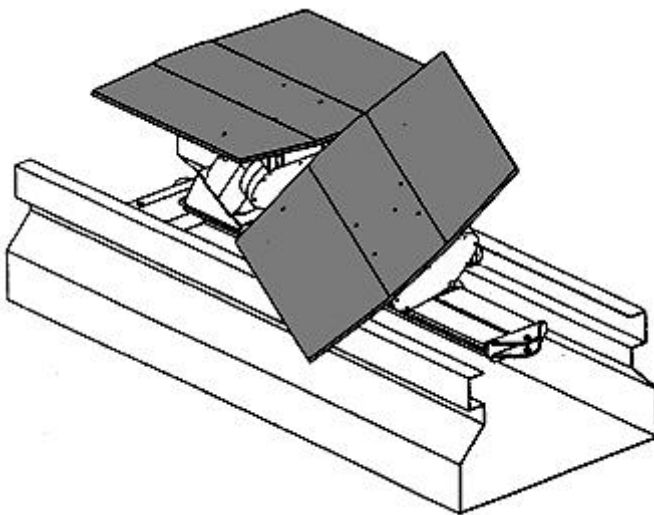
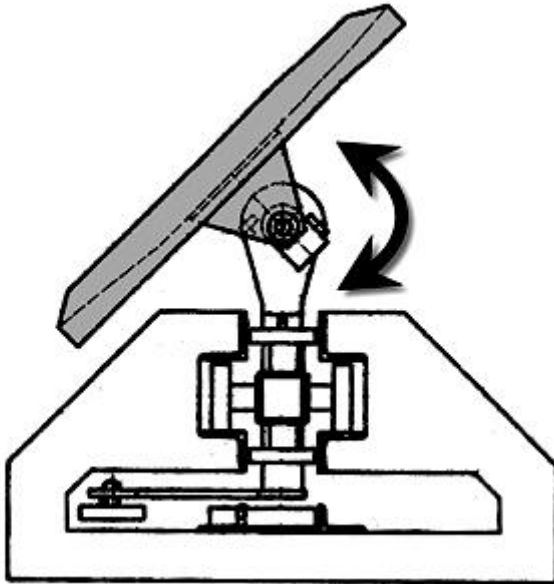
**References*****Informative references***

*Attention is drawn to the following places, which may be of interest for search:*

Operation of carriers (FTCLA)	3F015/DA02
-------------------------------	------------

## B65G 47/965

{tilting about a sided-axis, i.e. the axis is not located near the center-line of the load-carrier}

### Definition statement

*This place covers:*

Illustrative example of subject matter classified in this group:

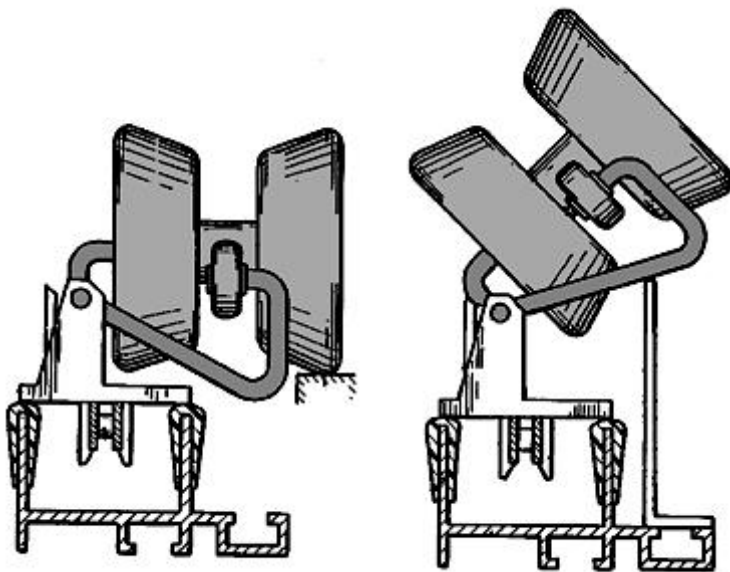
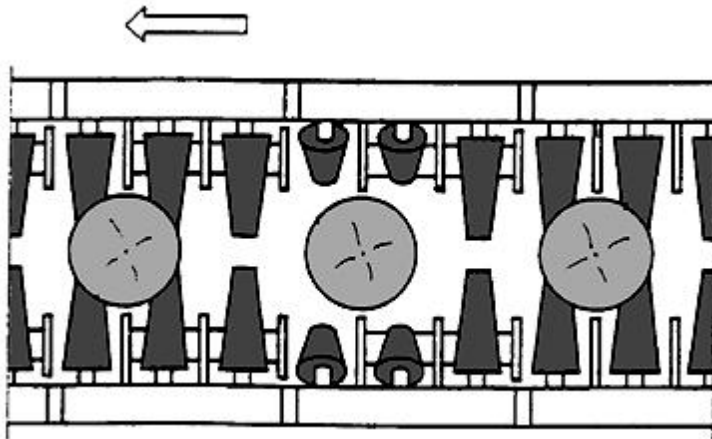

**B65G 47/967****{tilting about an axis perpendicular to the conveying direction}****Definition statement***This place covers:*

Illustrative example of subject matter classified in this group:

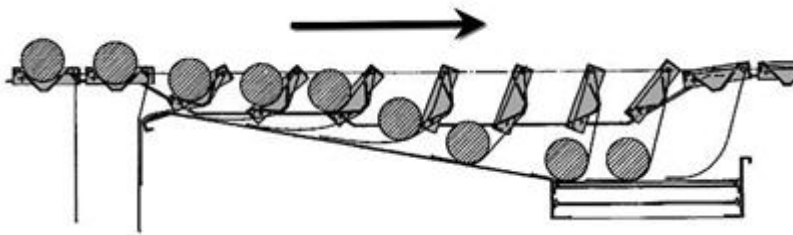
**References****Informative references***Attention is drawn to the following places, which may be of interest for search:*

Dumping, tripping, or releasing load carriers	<a href="#">B65G 47/38</a>
-----------------------------------------------	----------------------------

**B65G 49/00****Conveying systems characterised by their application for specified purposes not otherwise provided for****References****Informative references***Attention is drawn to the following places, which may be of interest for search:*

For conveying sheet material	<a href="#">B65H</a>
Electroplating	<a href="#">C25D</a>

**B65G 49/025****{conveyor feeding and discharging means}****Definition statement***This place covers:*

Illustrative example of subject matter classified in this group:

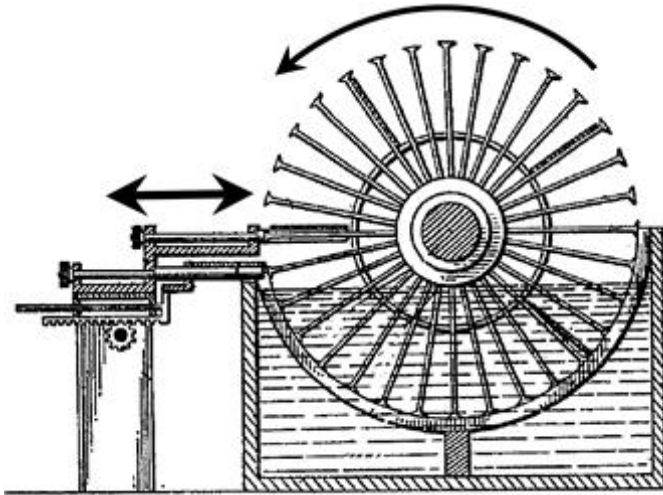
**References*****Informative references****Attention is drawn to the following places, which may be of interest for search:*

Devices for transferring articles or materials between conveyors for articles	<a href="#">B65G 47/61</a>
Specially adapted for workpieces of definite length	<a href="#">B65G 49/0409</a>



**B65G 49/04**

the workpieces being immersed and withdrawn by movement in a vertical direction

**Definition statement**

*This place covers:*

Illustrative example of subject matter classified in this group:

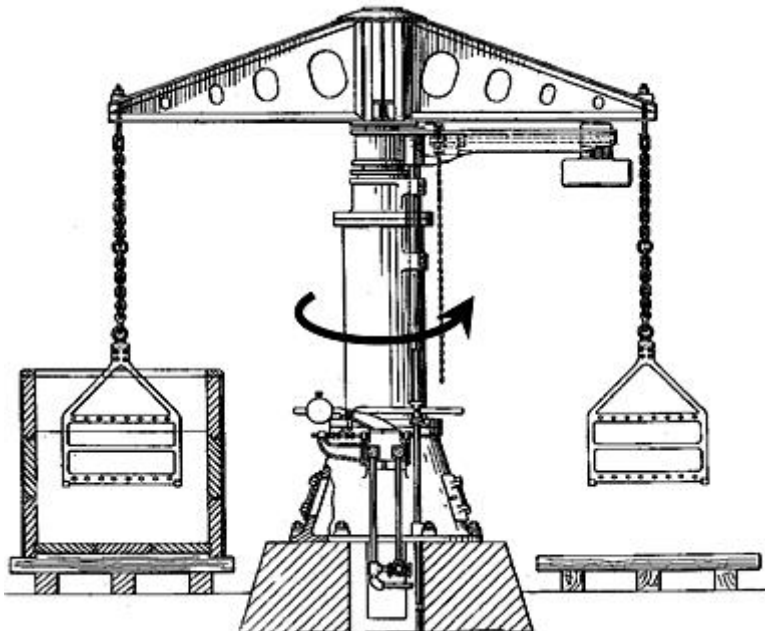
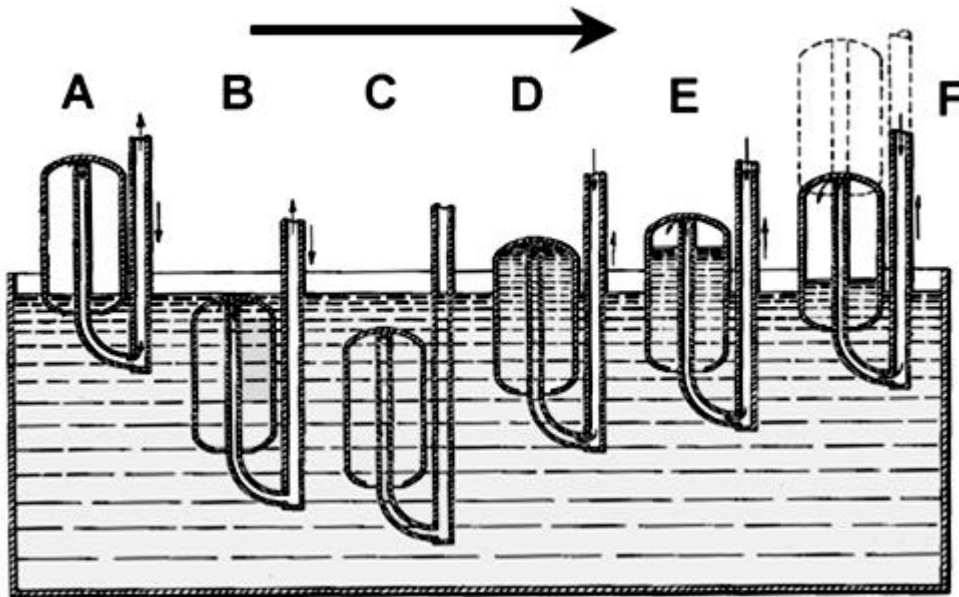

## B65G 49/0404

{specially adapted for very long workpieces, e.g. chains, cables or belts}

### Definition statement

*This place covers:*

Illustrative example of subject matter classified in this group:

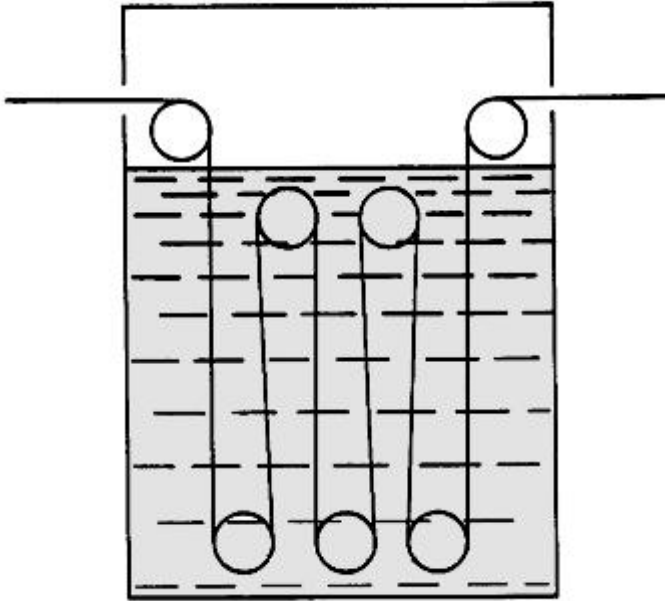

**B65G 49/0409**

{specially adapted for workpieces of definite length}

**Definition statement**

*This place covers:*

Illustrative example of subject matter classified in this group:

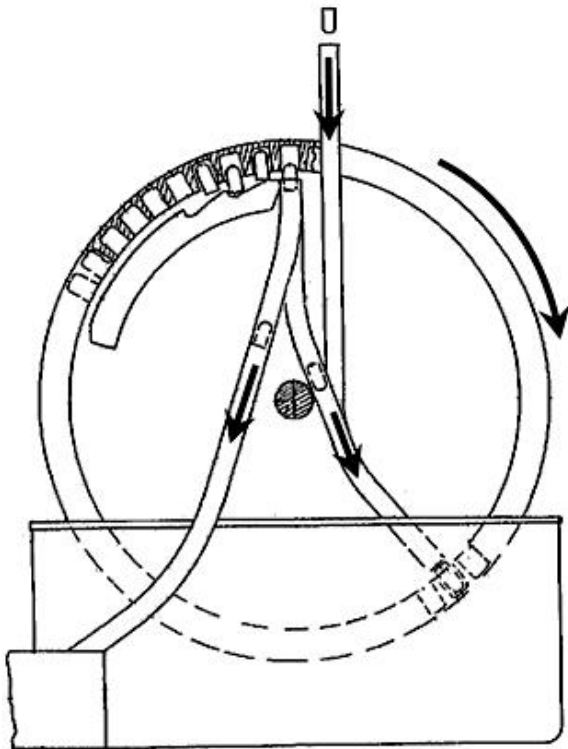
**References****Limiting references**

*This place does not cover:*

Especially adapted for very long workpieces	<a href="#">B65G 49/0404</a>
---------------------------------------------	------------------------------

**B65G 49/0413**

{arrangements for conveyance through the bath}

**Definition statement**

*This place covers:*

Illustrative example of subject matter classified in this group:

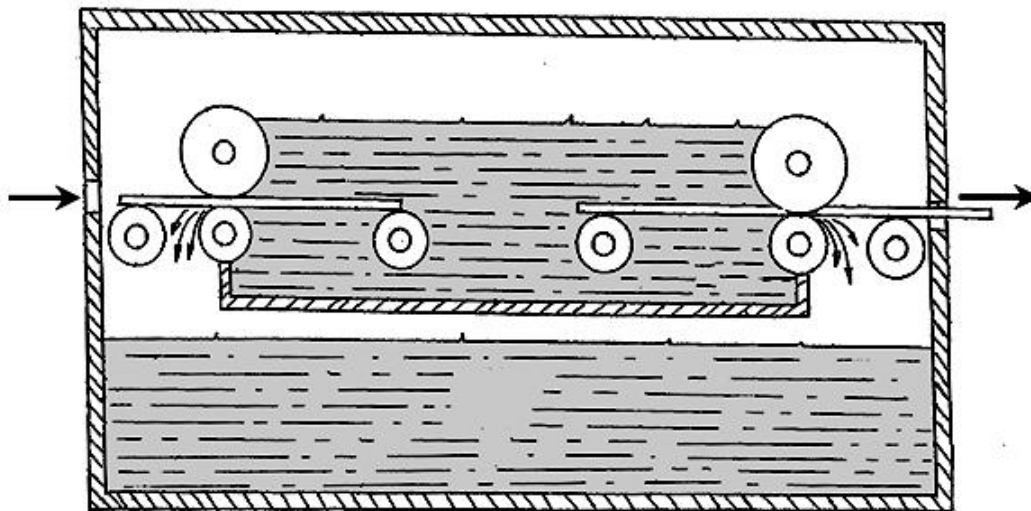
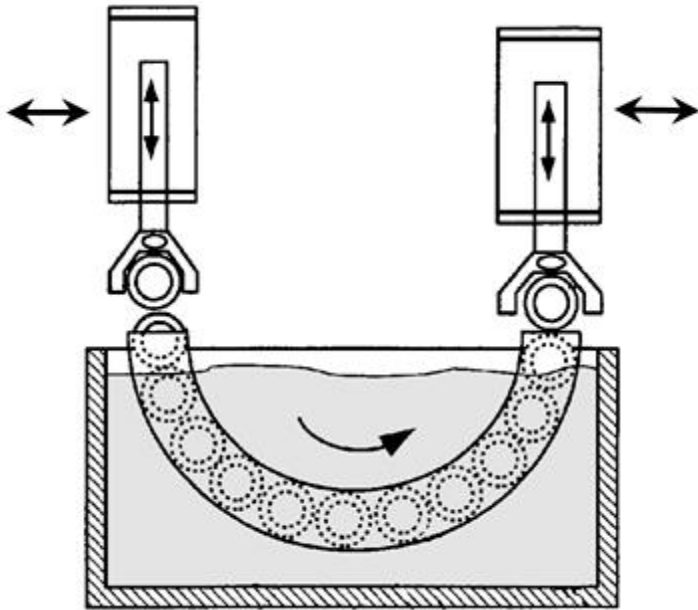

## B65G 49/0418

{chain or belt conveyors}

### Definition statement

*This place covers:*

Illustrative example of subject matter classified in this group:

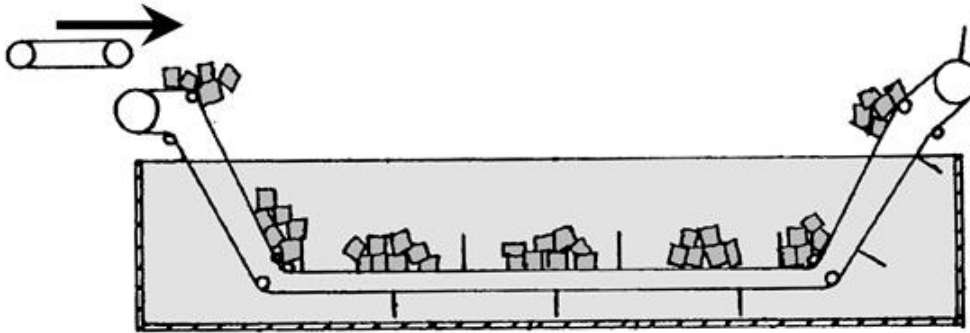

### References

#### *Informative references*

*Attention is drawn to the following places, which may be of interest for search:*

The circuit being fixed	<a href="#">B65G 49/045</a>
-------------------------	-----------------------------

## B65G 49/0422

{screws}

### Definition statement

*This place covers:*

Illustrative example of subject matter classified in this group:

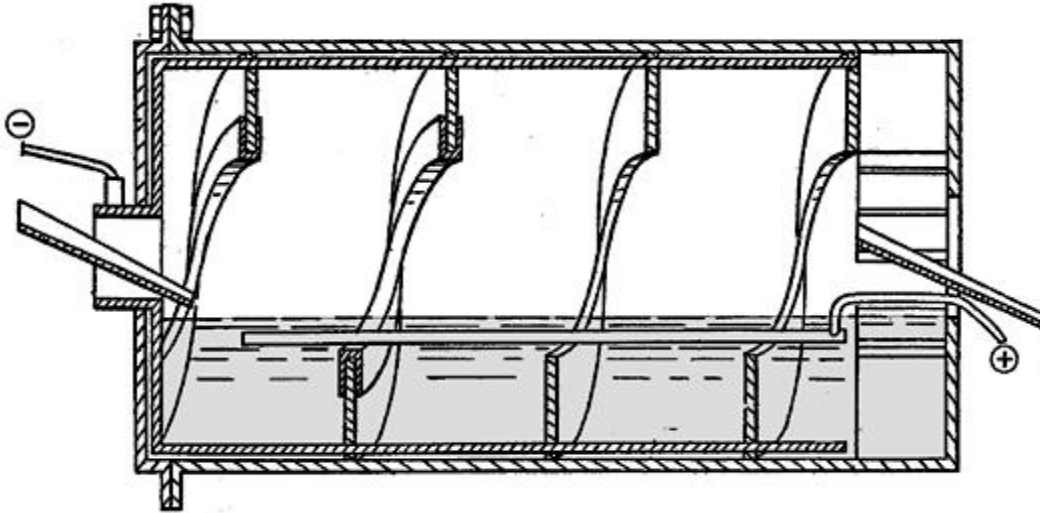

**B65G 49/0427****{jigging conveyors}****Definition statement***This place covers:*

Illustrative example of subject matter classified in this group:

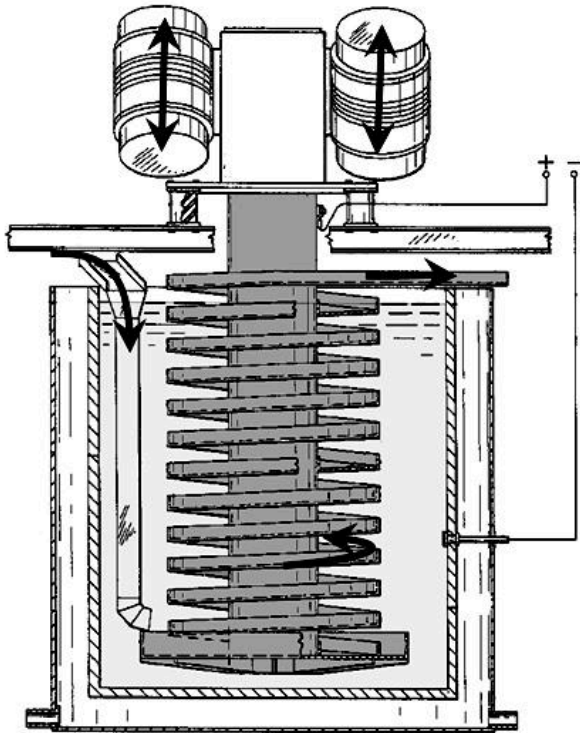
**References*****Informative references****Attention is drawn to the following places, which may be of interest for search:*

Jigging conveyors	<a href="#">B65G 27/00</a>
-------------------	----------------------------

## B65G 49/0431

{reciprocating conveying means}

### Definition statement

*This place covers:*

Illustrative example of subject matter classified in this group:

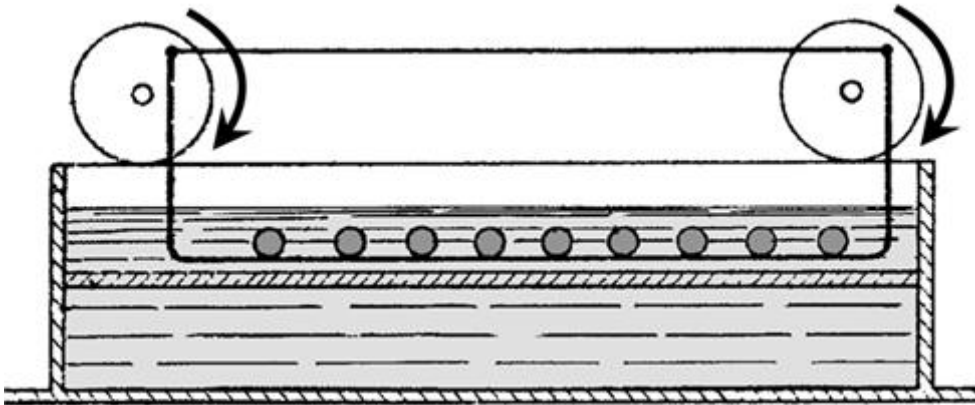

### References

#### *Informative references*

*Attention is drawn to the following places, which may be of interest for search:*

Conveyors comprising a cyclically-moving	<a href="#">B65G 25/00</a>
Kinds of mechanical conveyors	<a href="#">B65G 35/00</a>



**B65G 49/044****{along a continuous circuit}****Definition statement***This place covers:*

Illustrative example of subject matter classified in this group:

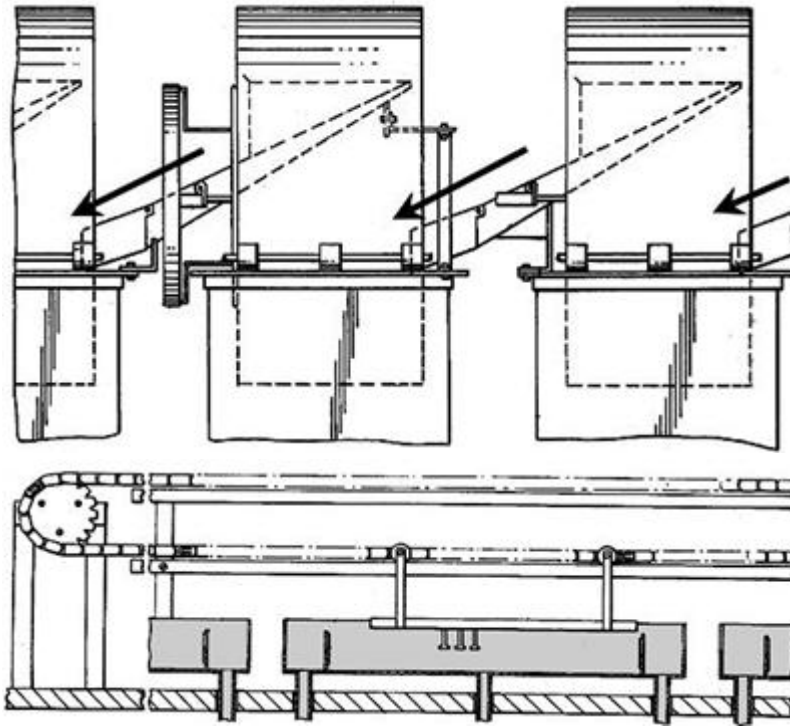
**References****Informative references***Attention is drawn to the following places, which may be of interest for search:*

Screws	<a href="#">B65G 49/0422</a>
--------	------------------------------

**B65G 49/0445**

{the circuit being movable vertically as a whole}

**Definition statement**

*This place covers:*

Illustrative example of subject matter classified in this group:

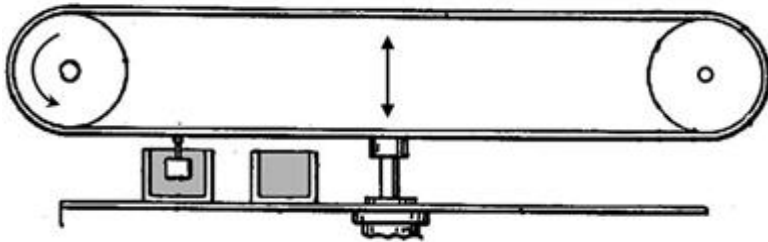
**B65G 49/045**

{the circuit being fixed}

**Definition statement**

*This place covers:*

Illustrative example of subject matter classified in this group:

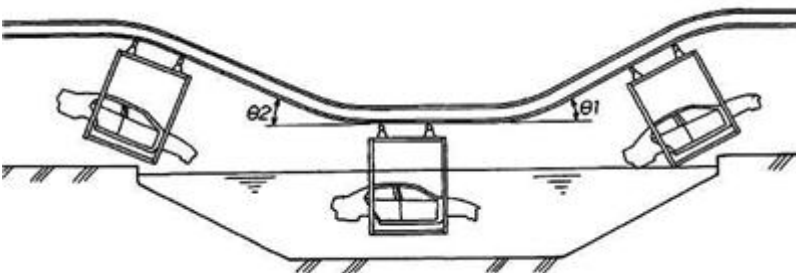
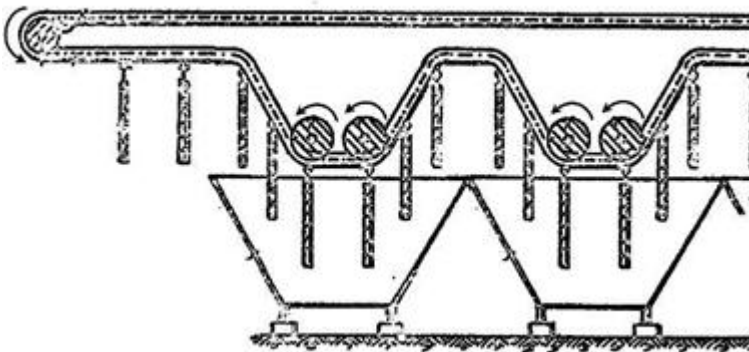

## B65G 49/0454

{by means of containers -or workpieces- carriers (containers or carriers as such see [C25D 17/00](#))}

### Definition statement

*This place covers:*

Illustrative example of subject matter classified in this group:

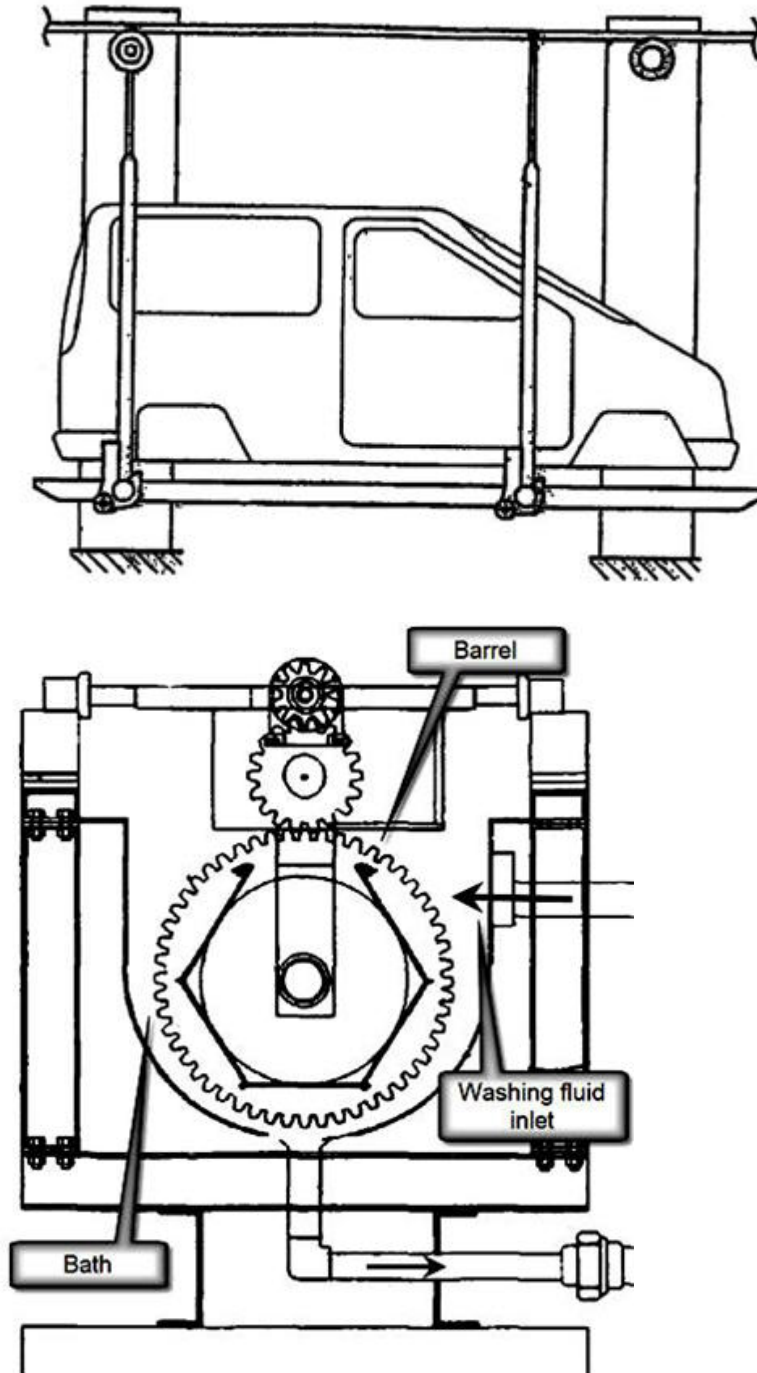

## References

### Informative references

Attention is drawn to the following places, which may be of interest for search:

For electroplating	<a href="#">C25D 17/00</a>
--------------------	----------------------------

## B65G 49/0459

{movement in a vertical direction is caused by self-contained means}

### Definition statement

*This place covers:*

Illustrative example of subject matter classified in this group:



## B65G 49/0463

{movement in a vertical direction is caused by lifting means or fixed or adjustable guiding means located at the bath area}

### Definition statement

*This place covers:*

Illustrative example of subject matter classified in this group:

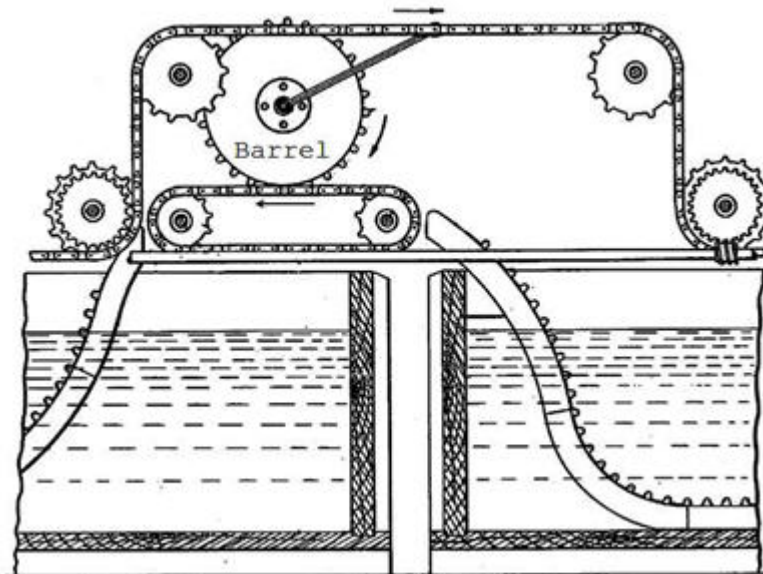

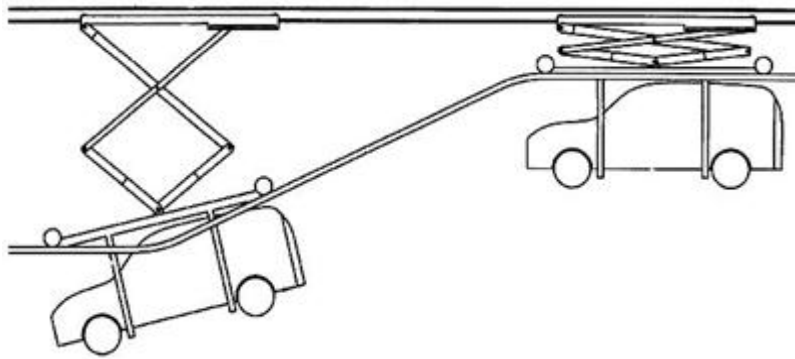

**References**

**Informative references**

Attention is drawn to the following places, which may be of interest for search:

With lifting means locating at the bath area	<a href="#">B65G 49/0481</a>
----------------------------------------------	------------------------------

**B65G 49/0468**

{without container or workpieces carriers}

**Definition statement**

This place covers:

Illustrative example of subject matter classified in this group:

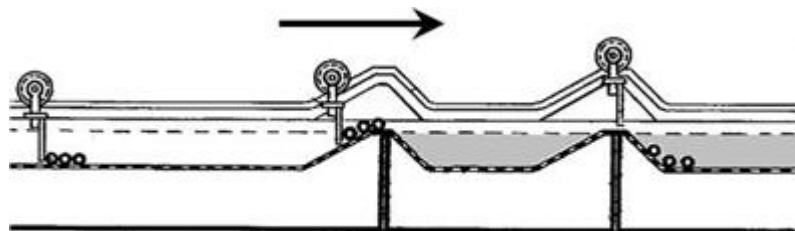

**References**

**Informative references**

Attention is drawn to the following places, which may be of interest for search:

Arrangements for conveyance through the bath	<a href="#">B65G 49/0413</a>
Chain or belt conveyors	<a href="#">B65G 49/0418</a>
Screws	<a href="#">B65G 49/0422</a>
Jiggling conveyors	<a href="#">B65G 49/0427</a>
Reciprocating conveying means	<a href="#">B65G 49/0431</a>

## B65G 49/0477

{with lifting means for circuit parts}

### Definition statement

*This place covers:*

Illustrative example of subject matter classified in this group:

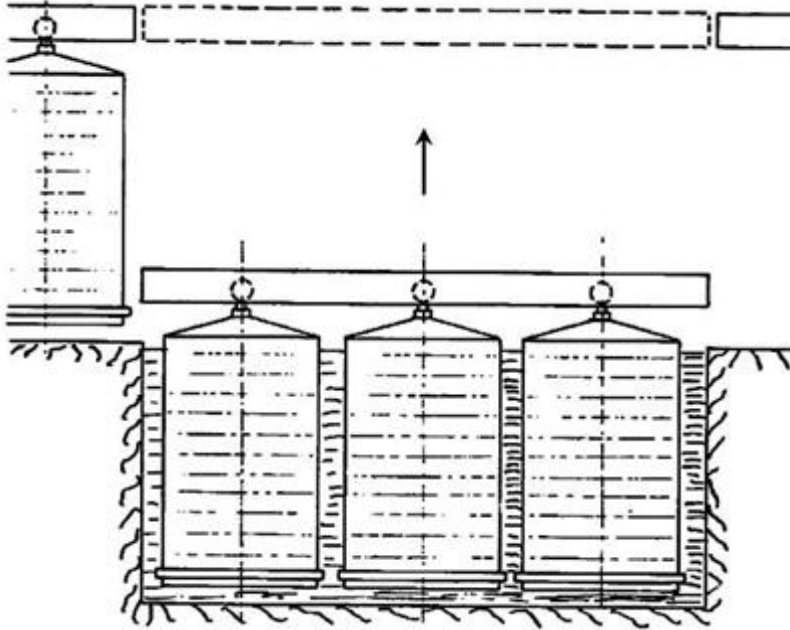

**B65G 49/0481**

{with lifting means locating at the bath area}

**Definition statement**

*This place covers:*

Illustrative example of subject matter classified in this group:

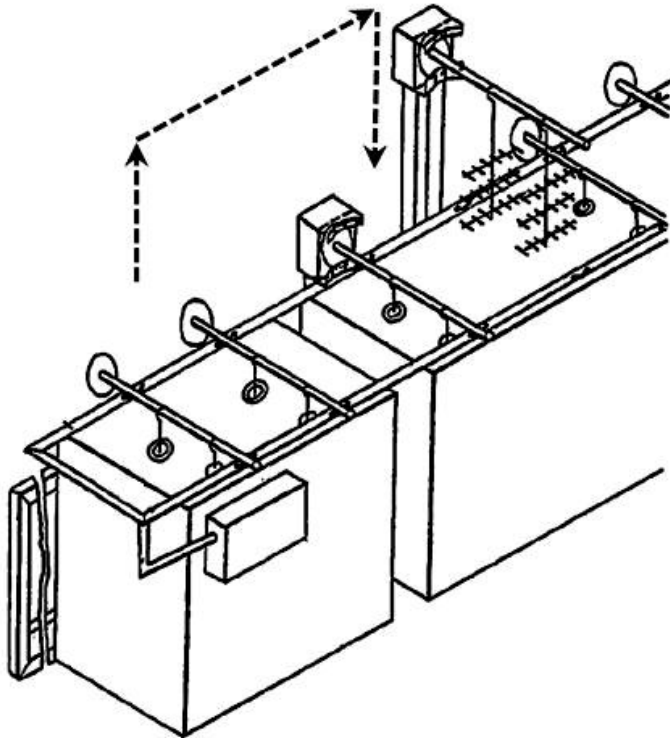
**B65G 49/0486**

{provided with rotating or pivoting arms}

**Definition statement**

*This place covers:*

Only when articles are taken from one support to the next

Illustrative example of subject matter classified in this group:

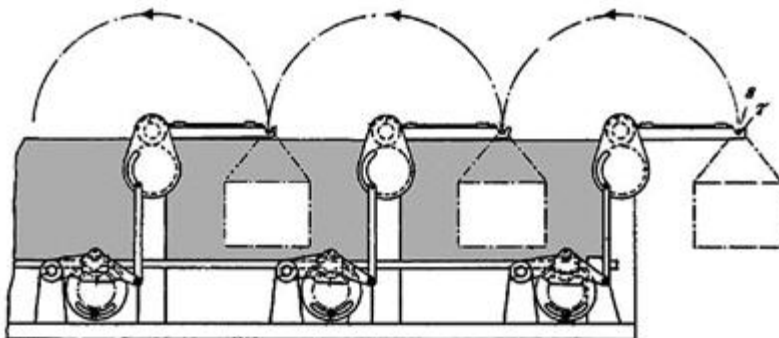



## References

### Limiting references

*This place does not cover:*

Along a continuous circuit	<a href="#">B65G 49/044</a>
----------------------------	-----------------------------

### Informative references

*Attention is drawn to the following places, which may be of interest for search:*

Reciprocating conveying means	<a href="#">B65G 49/0431</a>
-------------------------------	------------------------------

## B65G 49/049

{provided with vertical guiding means}

### Definition statement

*This place covers:*

Illustrative example of subject matter classified in this group:

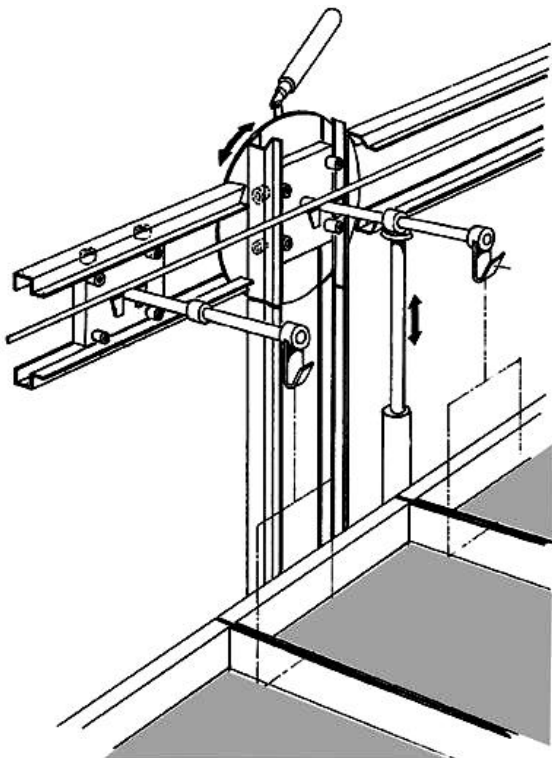

## References

### Informative references

*Attention is drawn to the following places, which may be of interest for search:*

Arrangements for conveyance through the bath	<a href="#">B65G 49/0413</a>
----------------------------------------------	------------------------------



**B65G 49/0495****{conveying by flows of fluids}****Definition statement***This place covers:*

Illustrative example of subject matter classified in this group:

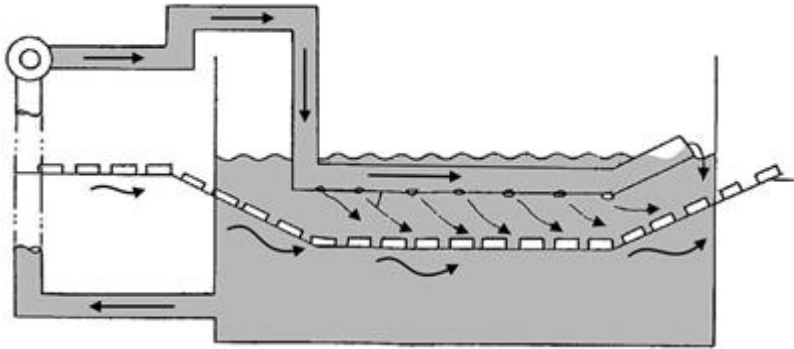
**References****Informative references***Attention is drawn to the following places, which may be of interest for search:*

Conveying materials in bulk through pipes or tubes by liquid pressure	<a href="#">B65G 53/30</a>
-----------------------------------------------------------------------	----------------------------

**B65G 49/06****for fragile sheets, e.g. glass****References****Application-oriented references***Examples of places where the subject matter of this place is covered when specially adapted, used for a particular purpose, or incorporated in a larger system:*

Transporting of glass products during their manufacture	<a href="#">C03B 35/00</a>
Transport of hot glass sheets	<a href="#">C03B 35/14</a>

**Informative references***Attention is drawn to the following places, which may be of interest for search:*

Substrate transfer through coating station	<a href="#">C23C</a>
Semi-conductor transfer between work station	<a href="#">H01L 21/677</a>

**Special rules of classification**Aspects related to conveying systems are also classed in [B65G 2249/00](#).

## B65G 49/08

### for ceramic mouldings

#### Definition statement

*This place covers:*

Illustrative example of subject matter classified in this group:

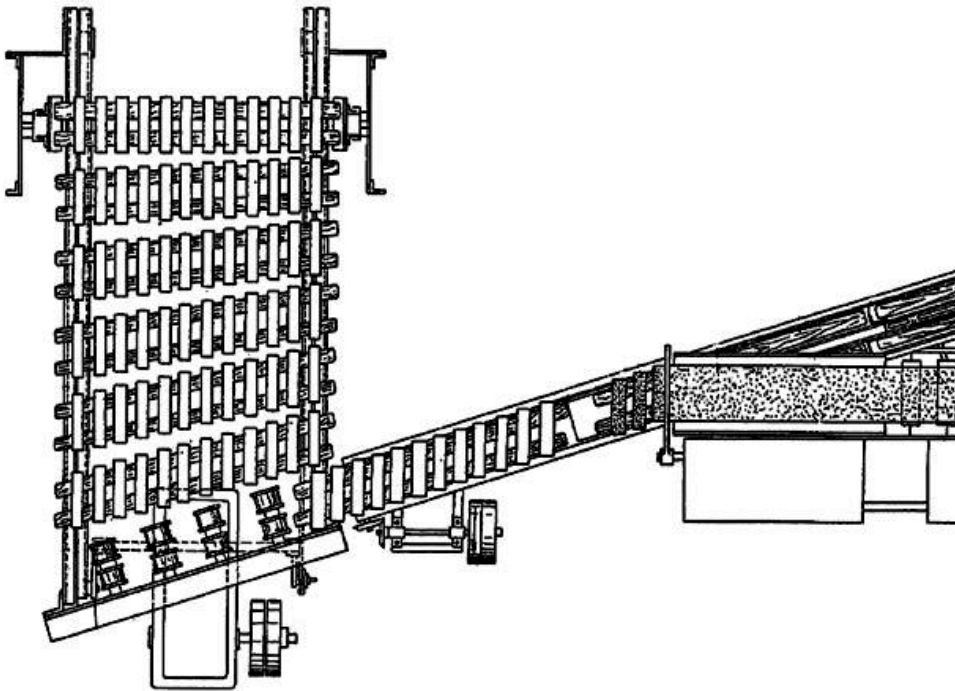

#### References

##### *Informative references*

*Attention is drawn to the following places, which may be of interest for search:*

Charging, discharging, manipulation with charge in kilns	<a href="#">F27D 3/00</a>
----------------------------------------------------------	---------------------------

**B65G 49/085**

{for loading or unloading racks or similar frames; loading racks therefor}

**Definition statement**

*This place covers:*

Illustrative example of subject matter classified in this group:

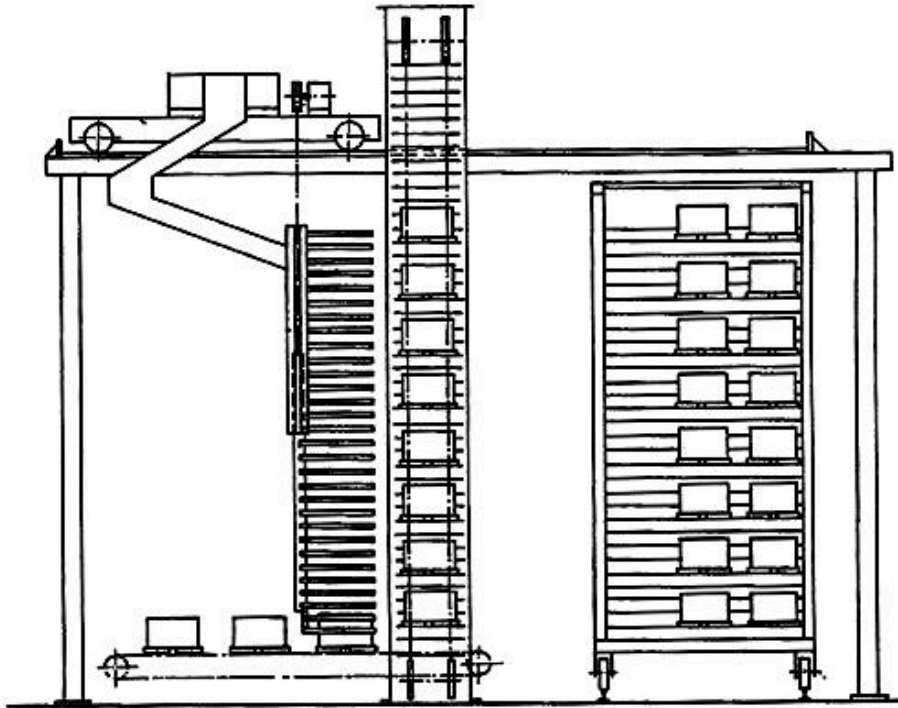
**References****Informative references**

*Attention is drawn to the following places, which may be of interest for search:*

Loading or unloading (of vehicles <a href="#">B65G 67/00</a> )	<a href="#">B65G 65/00</a>
----------------------------------------------------------------	----------------------------

**B65G 51/00**

Conveying articles through pipes or tubes by fluid flow or pressure; Conveying articles over a flat surface, e.g. the base of a trough, by jets located in the surface

**Definition statement**

*This place covers:*

For articles (otherwise [B65G 53/00](#)) and with fluid propulsion

Illustrative example of subject matter classified in this group:

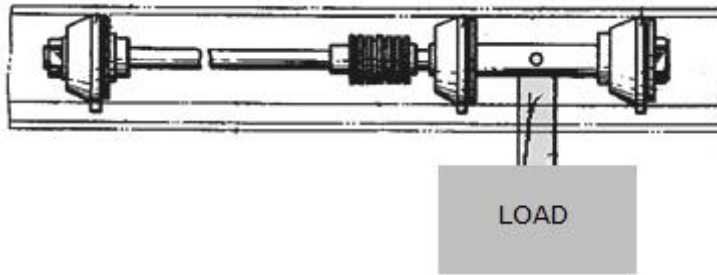

## References

### Application-oriented references

*Examples of places where the subject matter of this place is covered when specially adapted, used for a particular purpose, or incorporated in a larger system:*

Water roundabouts	<a href="#">B63G 3/00</a>
Pneumatic railways	<a href="#">B61B</a>

### Informative references

*Attention is drawn to the following places, which may be of interest for search:*

Electrostatic, electric or magnetic conveyors	<a href="#">B65G 54/025</a>
Pneumatic systems with propulsion devices between or alongside the rails	<a href="#">B61B 13/122</a>
Pumps	<a href="#">F04</a>
Fluid Dynamics, i.e. method or means for influencing the flow of gases or liquids	<a href="#">F15D</a>
Valves, taps, cocks	<a href="#">F16K</a>
Pipes, pipe joints, or associated device	<a href="#">F16L</a>

## B65G 51/01

**Hydraulic transport of articles ([B65G 51/04](#) takes precedence; water roundabouts [A63G 3/00](#))**

### Definition statement

*This place covers:*

Only with liquid propulsion

Illustrative example of subject matter classified in this group:

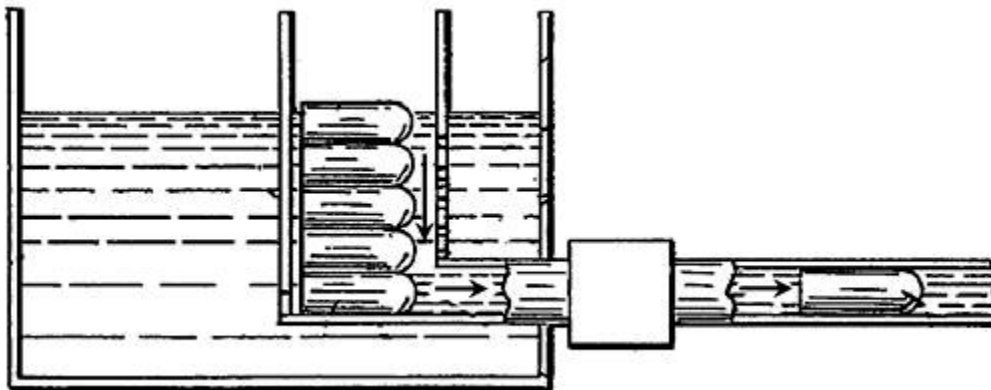
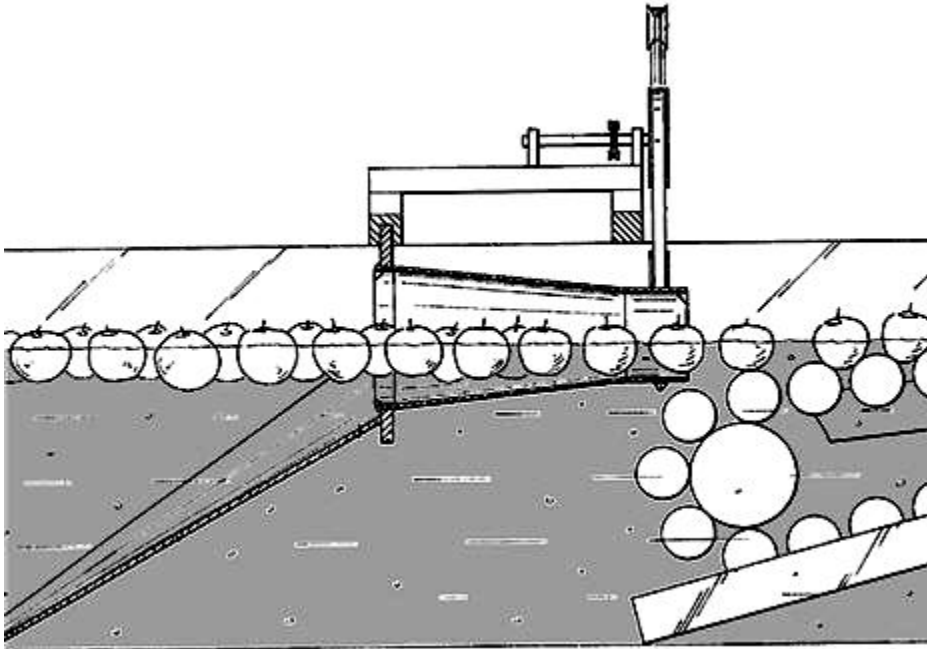

## References

### Informative references

Attention is drawn to the following places, which may be of interest for search:

Conveying materials in bulk through pipes or tubes by liquid pressure	<a href="#">B65G 53/30</a>
Machines or apparatus for treating harvested fruit, vegetables or flower bulbs in bulk, not otherwise provided for; peeling vegetables or fruit in bulk; apparatus for preparing animal feeding-stuffs	<a href="#">A23N</a>
Water roundabouts, e.g. freely floating	<a href="#">A63G 3/00</a>
Packaging fruit or vegetables by flotation means	<a href="#">B65B 25/045</a>

## B65G 51/02

Directly conveying the articles, e.g. slips, sheets, stockings, containers or workpieces, by flowing gases

### Definition statement

*This place covers:*

Illustrative example of subject matter classified in this group:

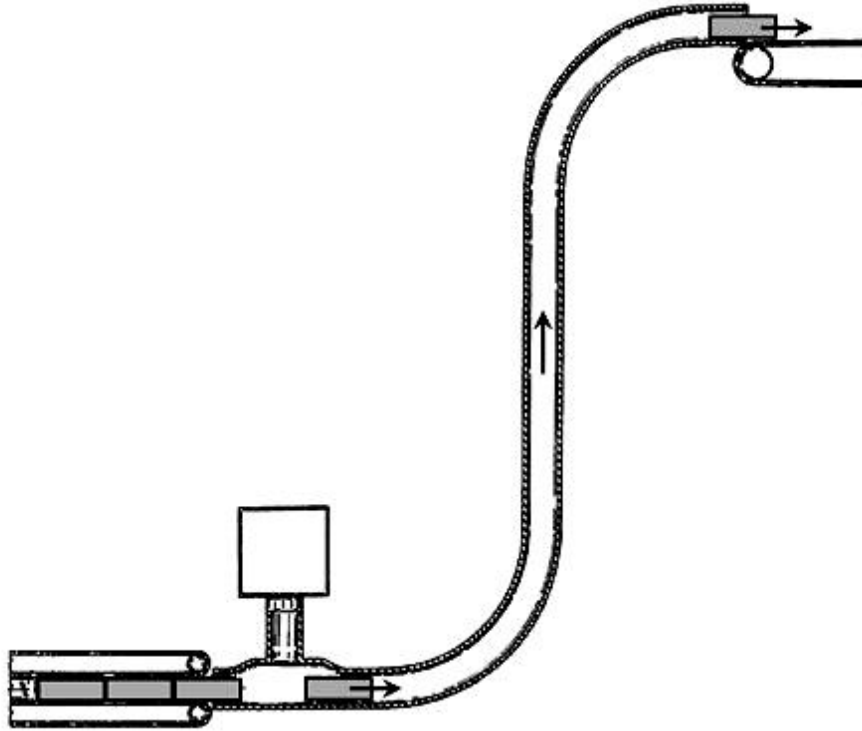

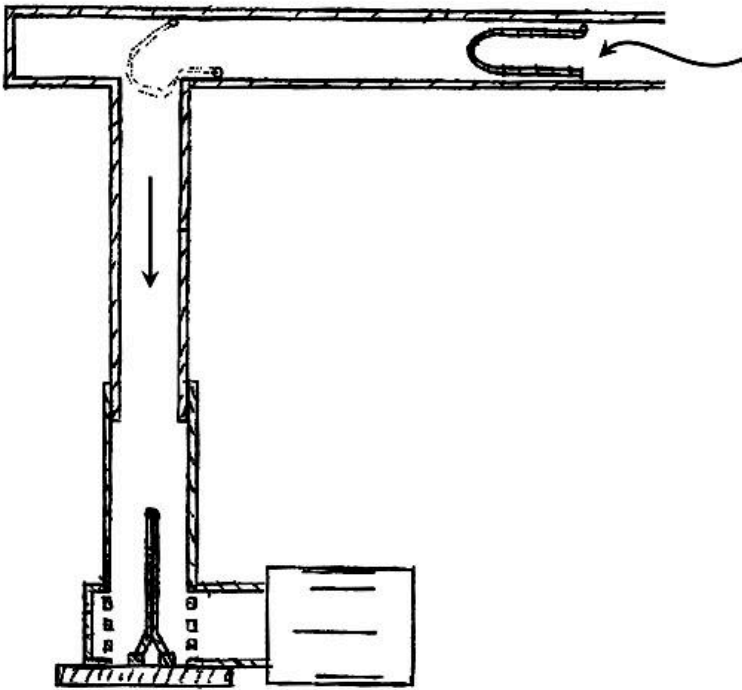

## References

### *Informative references*

*Attention is drawn to the following places, which may be of interest for search:*

Handling of coins or of paper currency or similar valuable papers	<a href="#">G07D</a>
-------------------------------------------------------------------	----------------------

## B65G 51/025

{Conveying ammunition through pipes}

### Definition statement

*This place covers:*

Illustrative example of subject matter classified in this group:

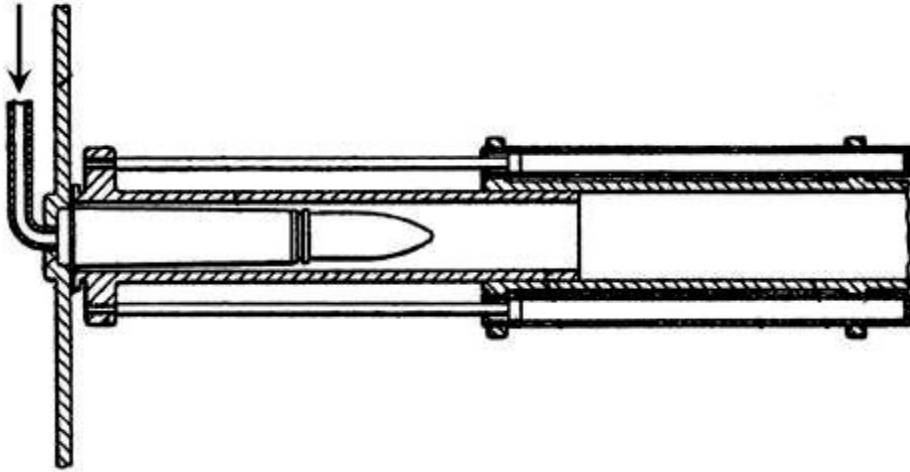



**B65G 51/03**

over a flat surface or in troughs

**Definition statement**

*This place covers:*

Illustrative example of subject matter classified in this group:

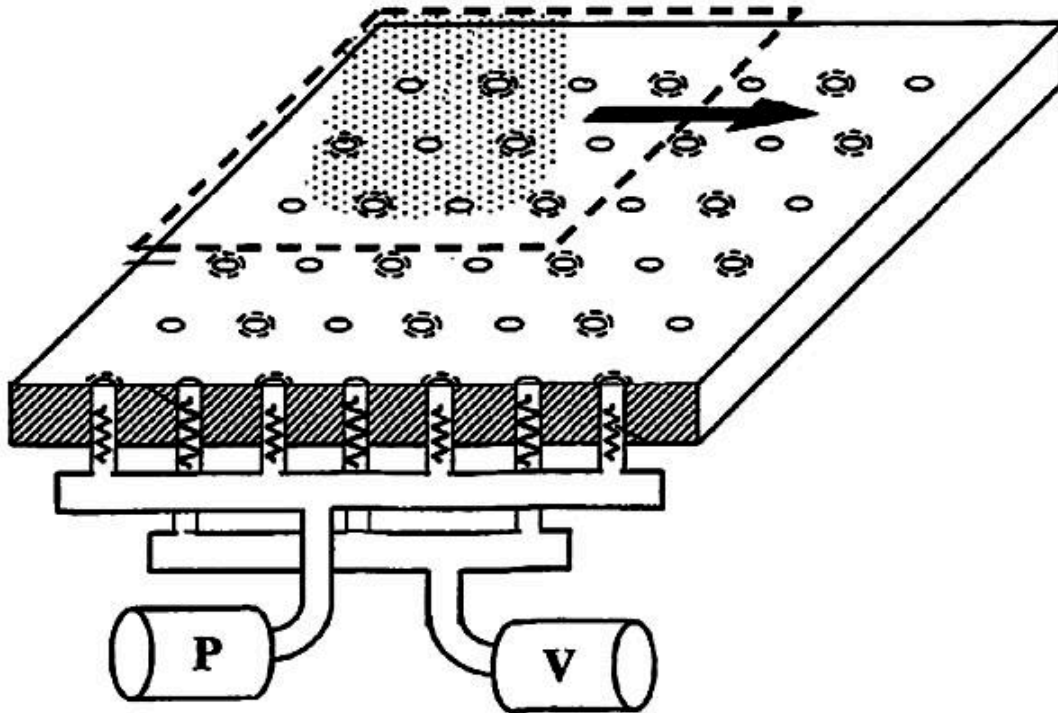
**References****Informative references**

*Attention is drawn to the following places, which may be of interest for search:*

Devices using fluid at high pressure supplied from an independent source to provide a cushion between load and ground.	<a href="#">B65G 7/06</a>
Transporting devices for sheet glass supported partially or completely on fluid cushions	<a href="#">B65G 49/065</a>
Apparatus specially adapted for handling semiconductor or electric solid state devices during manufacture or treatment thereof, using air tracks	<a href="#">H01L 21/67784</a>

## B65G 51/035

{for suspended articles, e.g. bottles}

### Definition statement

*This place covers:*

Illustrative example of subject matter classified in this group:

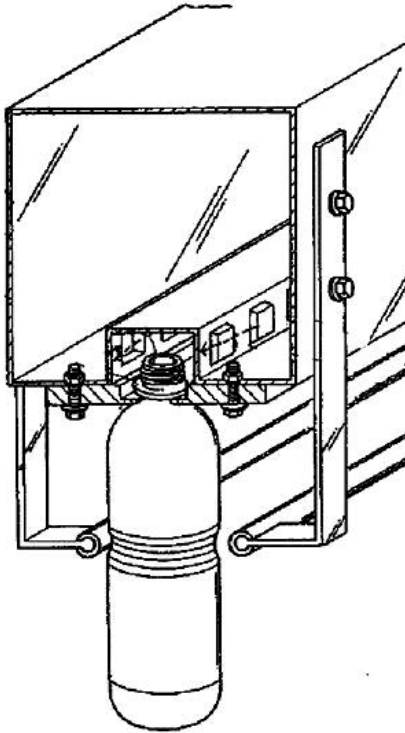

### References

#### *Informative references*

*Attention is drawn to the following places, which may be of interest for search:*

Suspended bottles	<a href="#">B65G 2201/0247</a>
-------------------	--------------------------------

## B65G 51/04

Conveying the articles in carriers having a cross-section approximating that of the pipe or tube; Tube mail systems

### Definition statement

*This place covers:*

Illustrative example of subject matter classified in this group:

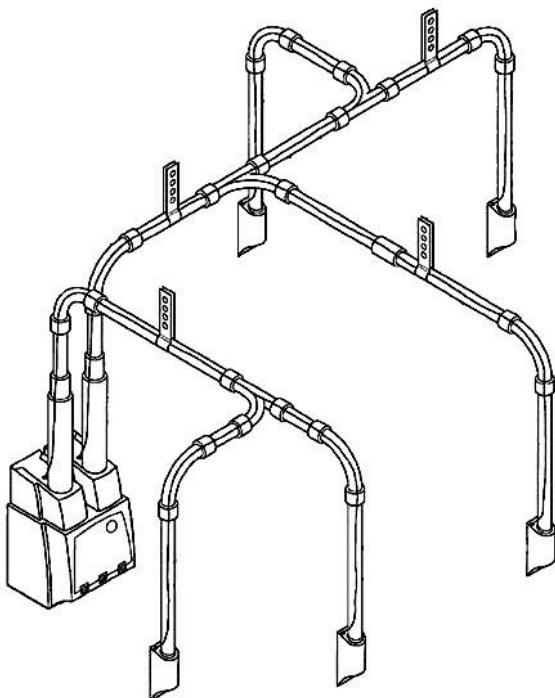
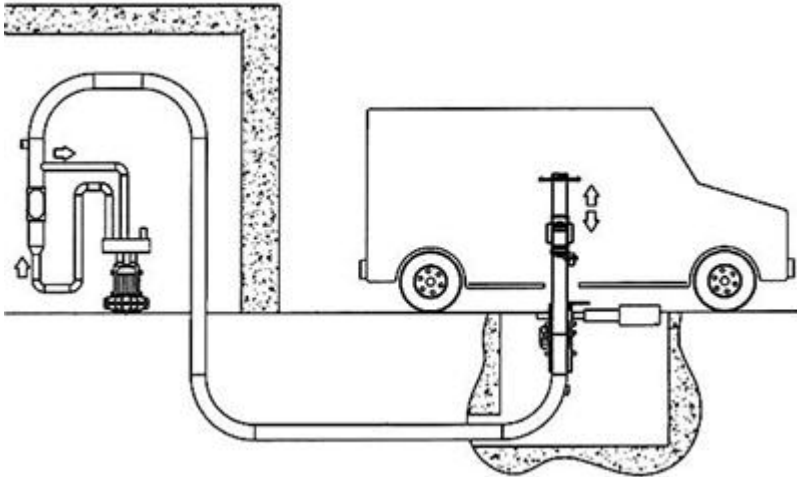

### References

#### Informative references

Attention is drawn to the following places, which may be of interest for search:

Gathering or removal of refuse otherwise than by receptacles or vehicles	<a href="#">B65F 5/005</a>
--------------------------------------------------------------------------	----------------------------

## B65G 51/06

### Despatch carriers for tube mail

#### Definition statement

*This place covers:*

Illustrative example of subject matter classified in this group:

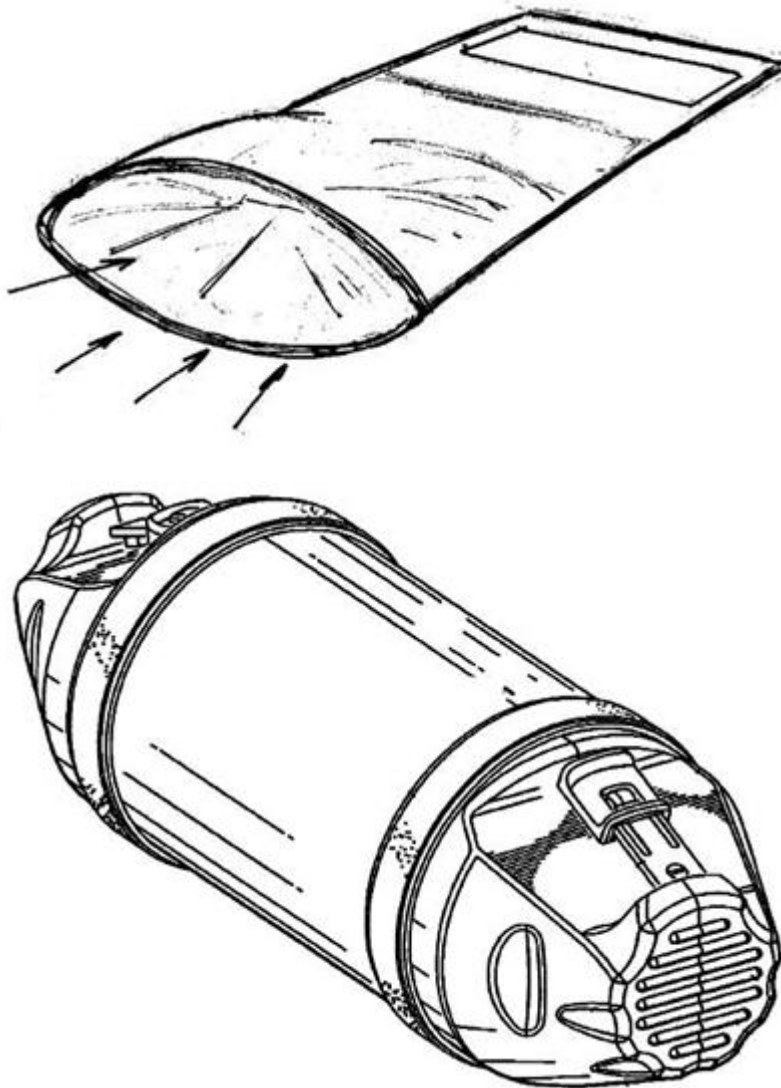

#### References

##### *Informative references*

*Attention is drawn to the following places, which may be of interest for search:*

Conveying articles with pipes or tubes by fluid flow or pressure according to indications on carriers
-------------------------------------------------------------------------------------------------------

<a href="#">B65G 51/42</a>
----------------------------

**B65G 51/08****Controlling or conditioning the operating medium****Definition statement**

*This place covers:*

Illustrative example of subject matter classified in this group:

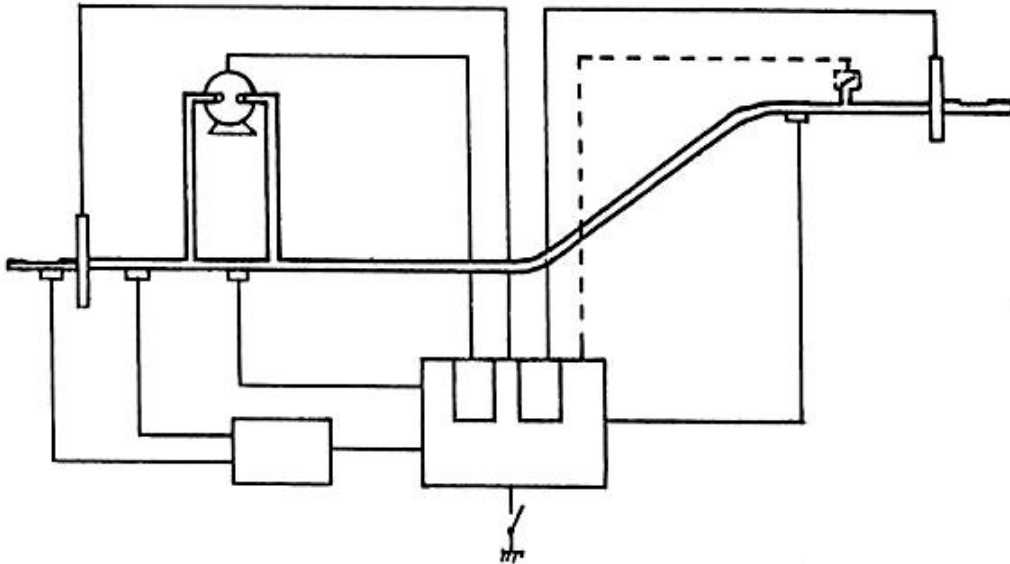
**References****Informative references**

*Attention is drawn to the following places, which may be of interest for search:*

Varying, e.g. starting and stopping, gas pressure or flow	<a href="#">B65G 51/16</a>
Two-way operation	<a href="#">B65G 51/34</a>
In compressors	<a href="#">F04</a>
Air-conditioning, e.g. de-watering, in pneumatic systems	<a href="#">F16L 55/09</a>

**B65G 51/10****at section junctions of pneumatic systems****Definition statement**

*This place covers:*

Only control at junctions of TWO tubes

Illustrative example of subject matter classified in this group:

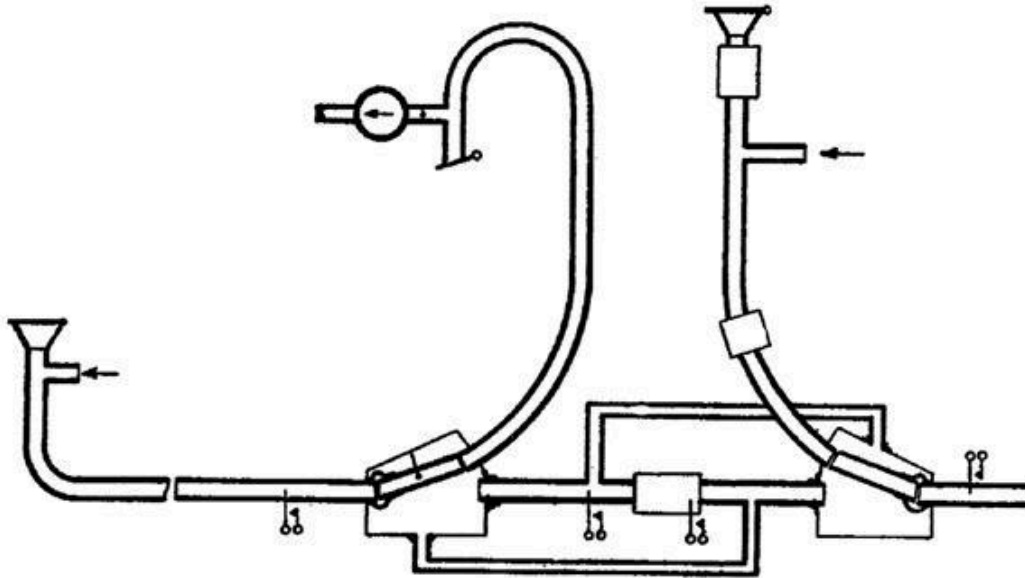

## **B65G 51/12**

### **Pneumatic gates**

#### **Definition statement**

*This place covers:*

Illustrative example of subject matter classified in this group:

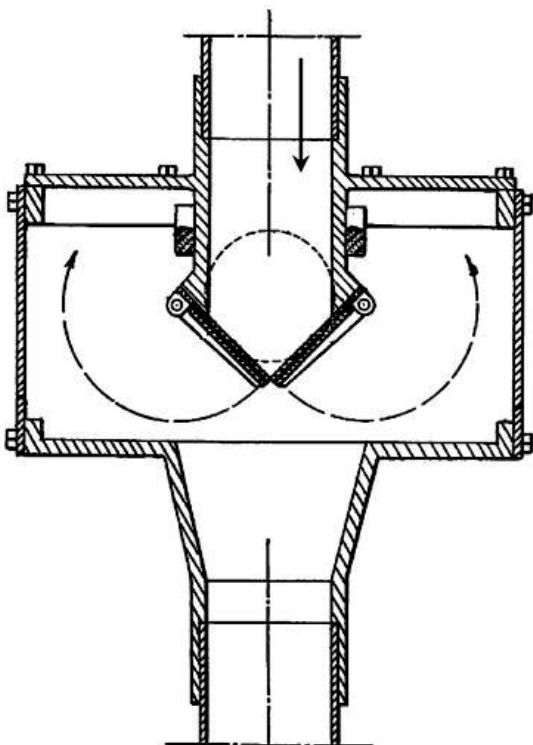

**B65G 51/14****Pneumatic sluices****Definition statement**

*This place covers:*

Illustrative example of subject matter classified in this group:

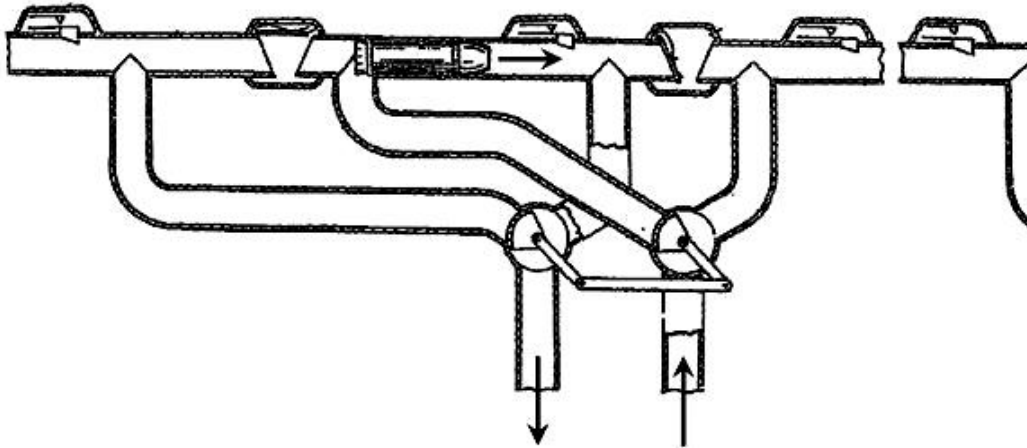
**B65G 51/16**

varying, e.g. starting or stopping, gas pressure or flow

**Definition statement**

*This place covers:*

Illustrative example of subject matter classified in this group:

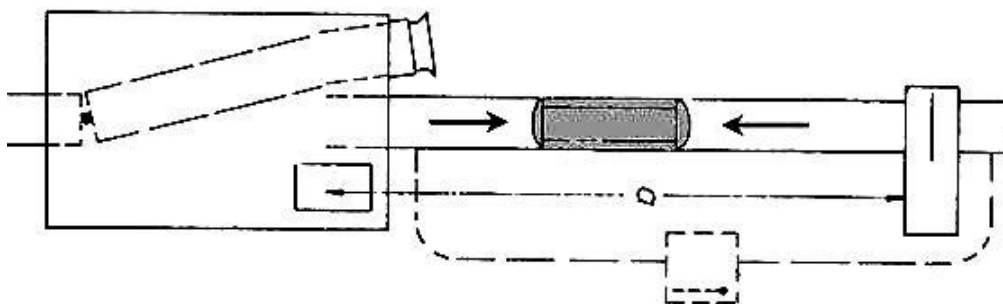
**References****Informative references**

Attention is drawn to the following places, which may be of interest for search:

Braking arrangements	<a href="#">B65G 51/20</a>
----------------------	----------------------------

## B65G 51/18

### Adaptations of pipes or tubes; Pipe or tube joints

#### Definition statement

*This place covers:*

Illustrative example of subject matter classified in this group:

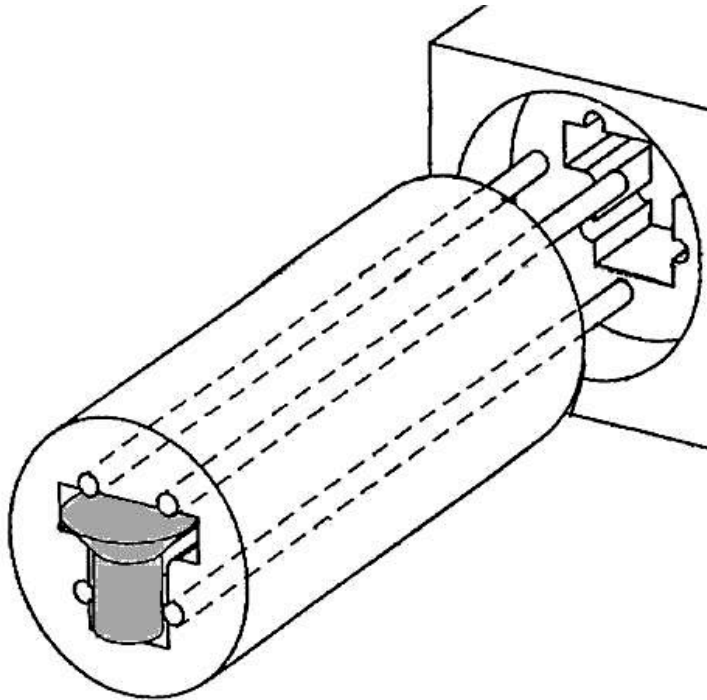
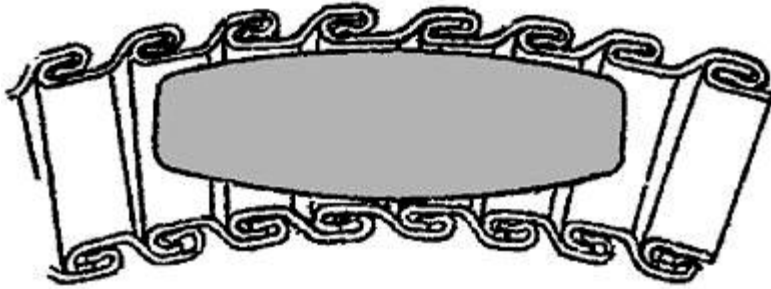



## B65G 51/20

### Braking arrangements

#### Definition statement

*This place covers:*

Illustrative example of subject matter classified in this group:

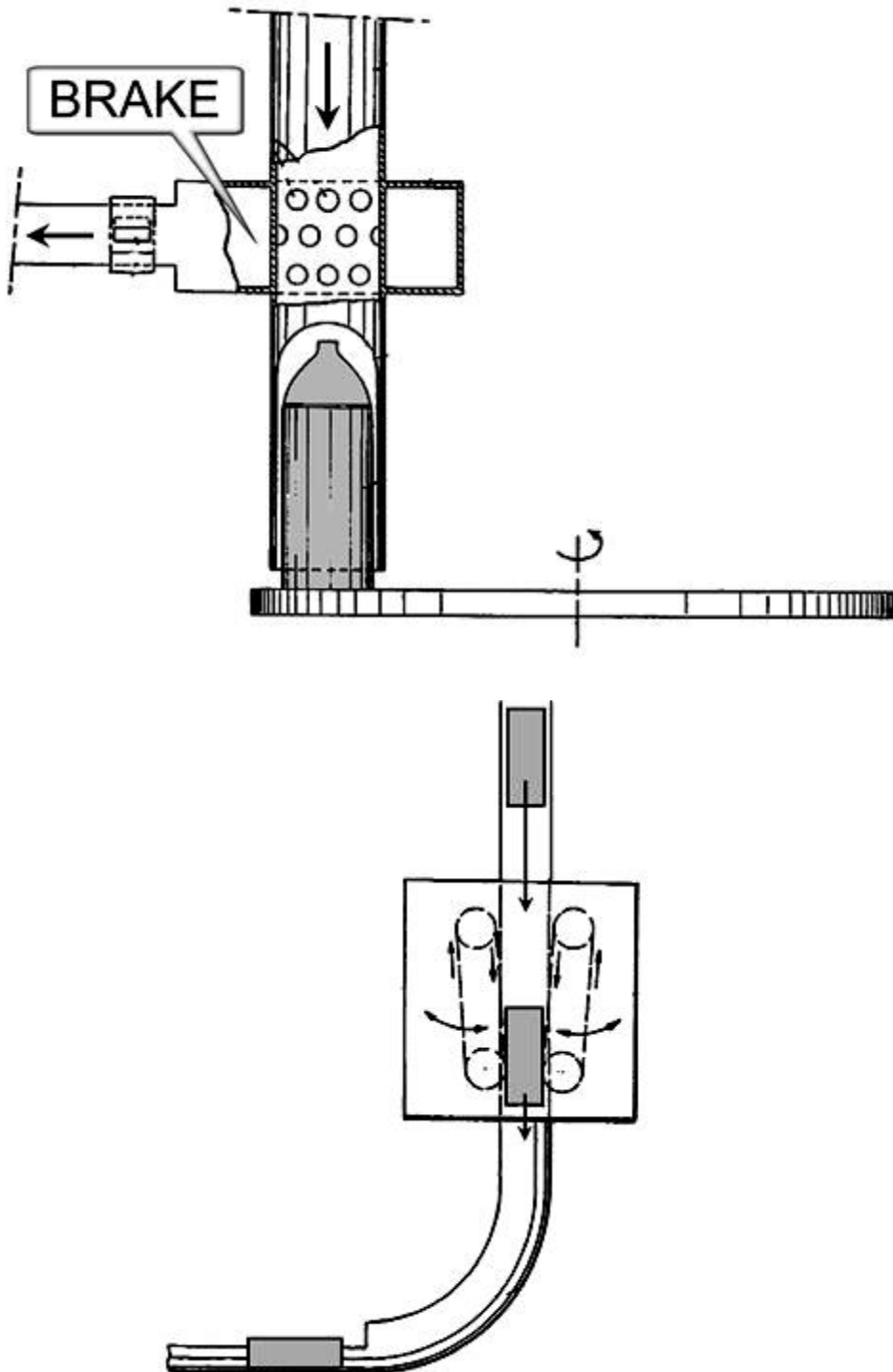

## B65G 51/22

Arrangements for stopping the carriers en route in order to control carrier sequence; Blocking or separating devices

### Definition statement

*This place covers:*

Illustrative example of subject matter classified in this group:

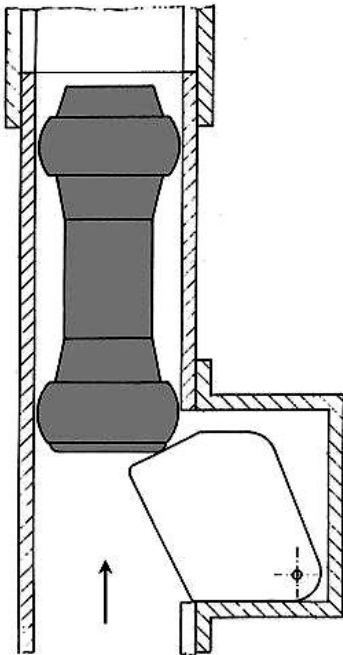
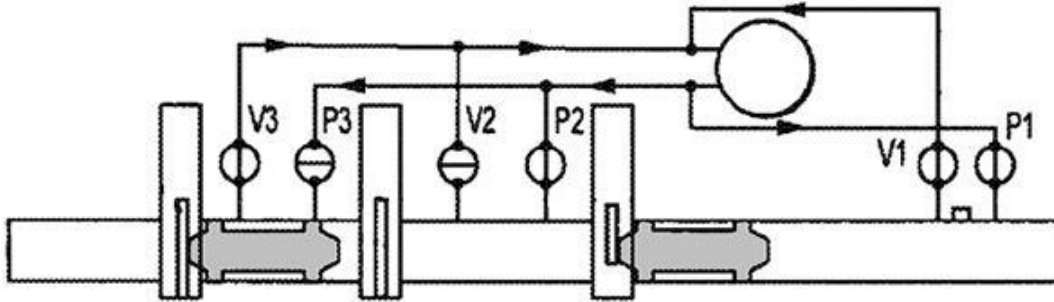

## B65G 51/24

### Switches

#### Definition statement

*This place covers:*

Illustrative example of subject matter classified in this group:

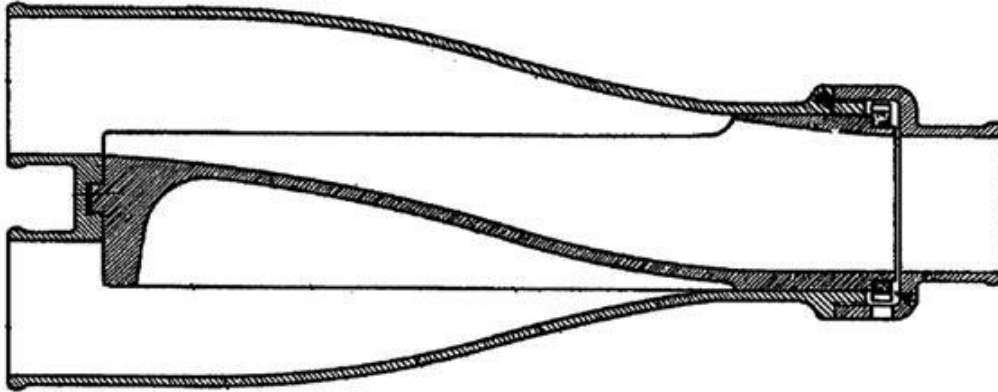

#### References

##### Informative references

*Attention is drawn to the following places, which may be of interest for search:*

Adaptation of pipes and tubes, switches	<a href="#">B65G 53/56</a>
-----------------------------------------	----------------------------

## B65G 51/26

### Stations

#### Definition statement

*This place covers:*

Only for dispatch AND delivery (combined)

Illustrative example of subject matter classified in this group:

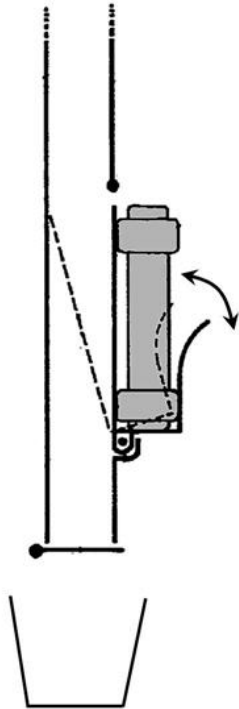

**References**

**Informative references**

Attention is drawn to the following places, which may be of interest for search:

Two way operation	<a href="#">B65G 51/34</a>
-------------------	----------------------------

## B65G 51/28

for despatch

### Definition statement

*This place covers:*

Illustrative example of subject matter classified in this group:

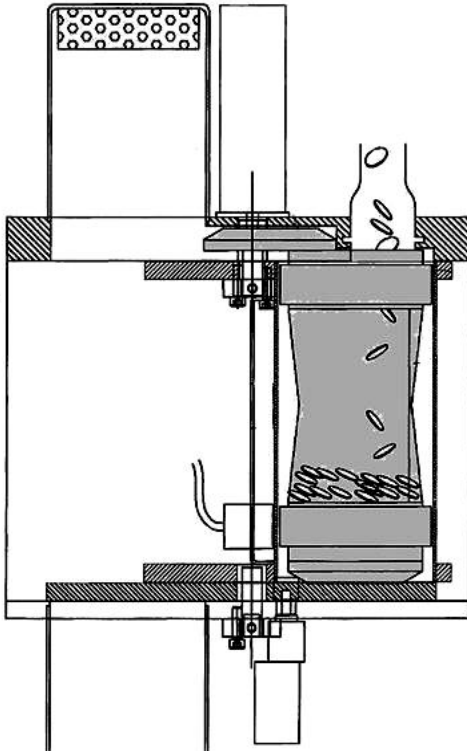

### References

#### *Informative references*

*Attention is drawn to the following places, which may be of interest for search:*

Stations	<a href="#">B65G 51/26</a>
----------	----------------------------

**B65G 51/30****for delivery****Definition statement***This place covers:*

Illustrative example of subject matter classified in this group:

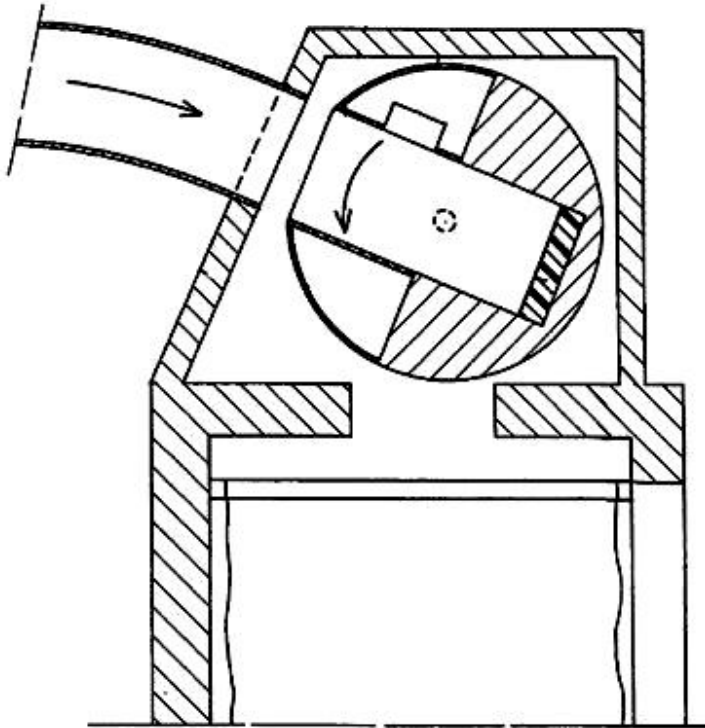
**References****Informative references***Attention is drawn to the following places, which may be of interest for search:*

Breaking arrangements	<a href="#">B65G 51/20</a>
Stations	<a href="#">B65G 51/26</a>

## B65G 51/32

for despatch, delivery, and transit

### Definition statement

*This place covers:*

Illustrative example of subject matter classified in this group:

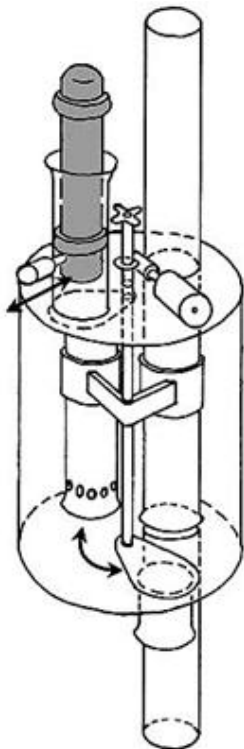
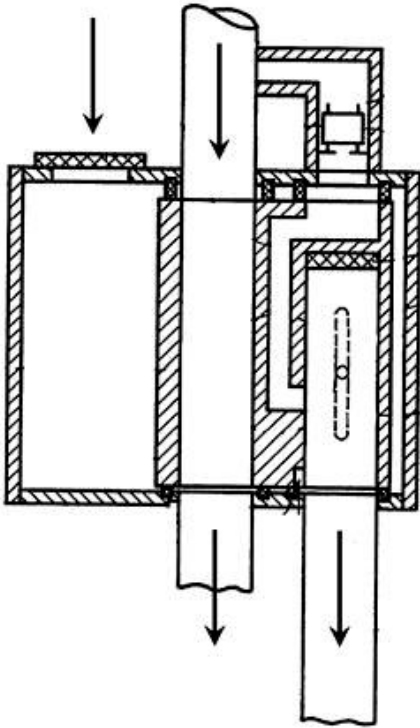

**References**

**Informative references**

Attention is drawn to the following places, which may be of interest for search:

Stations	<a href="#">B65G 51/26</a>
----------	----------------------------

**B65G 51/34**

**Two-way operation**

**Definition statement**

This place covers:

Illustrative example of subject matter classified in this group:

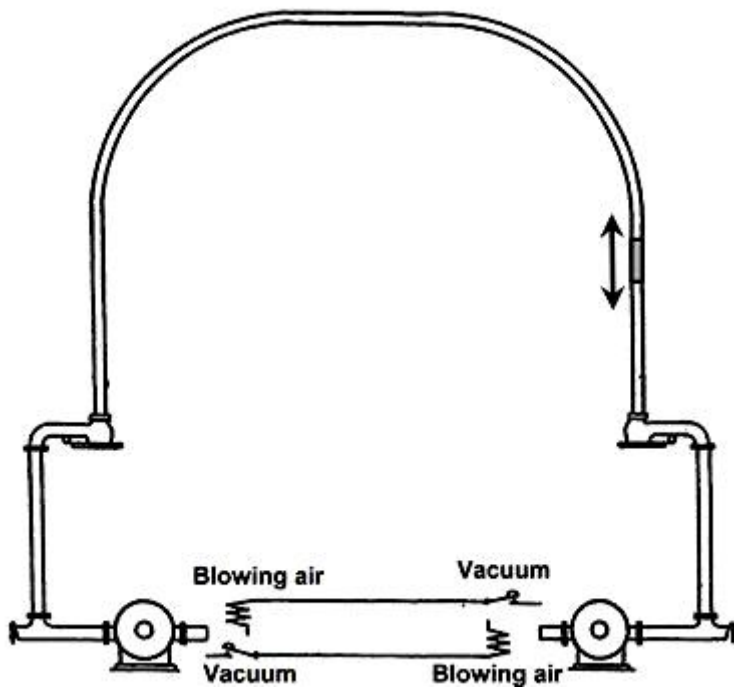

**References**

**Informative references**

Attention is drawn to the following places, which may be of interest for search:

Stations	<a href="#">B65G 51/26</a>
----------	----------------------------



## B65G 51/36

Other devices for indicating or controlling movements of carriers, e.g. for supervising individual tube sections, for counting carriers, for reporting jams or other operating difficulties

### Definition statement

*This place covers:*

Illustrative example of subject matter classified in this group:

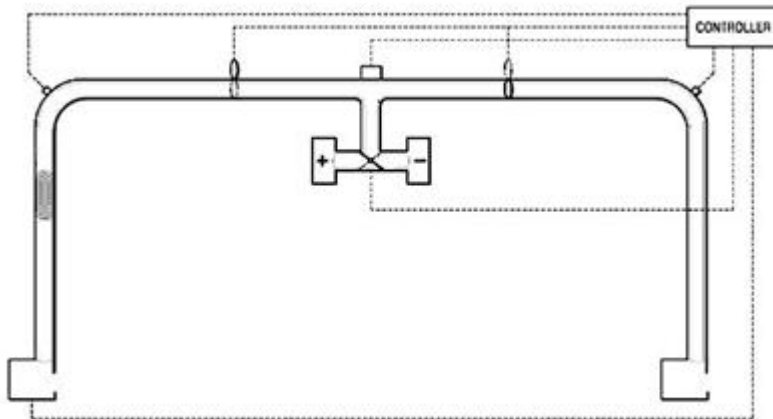

## B65G 51/38

### Contact devices on interior of tubes for detecting passage of carriers

#### Definition statement

*This place covers:*

Illustrative example of subject matter classified in this group:

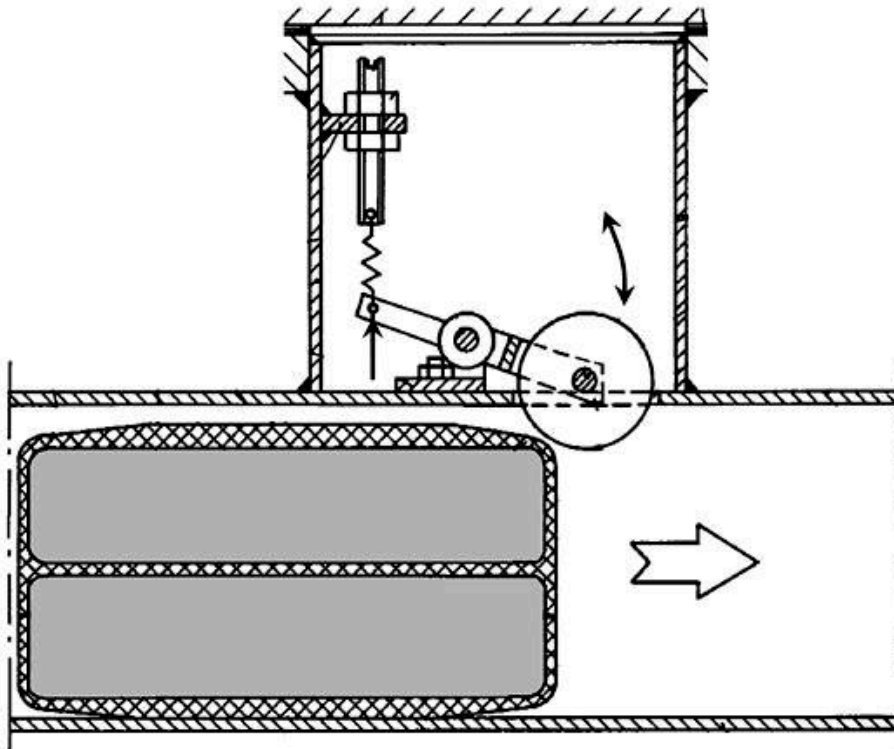

## B65G 51/40

### Automatically distributing the carriers to desired stations

#### Definition statement

*This place covers:*

Illustrative example of subject matter classified in this group:

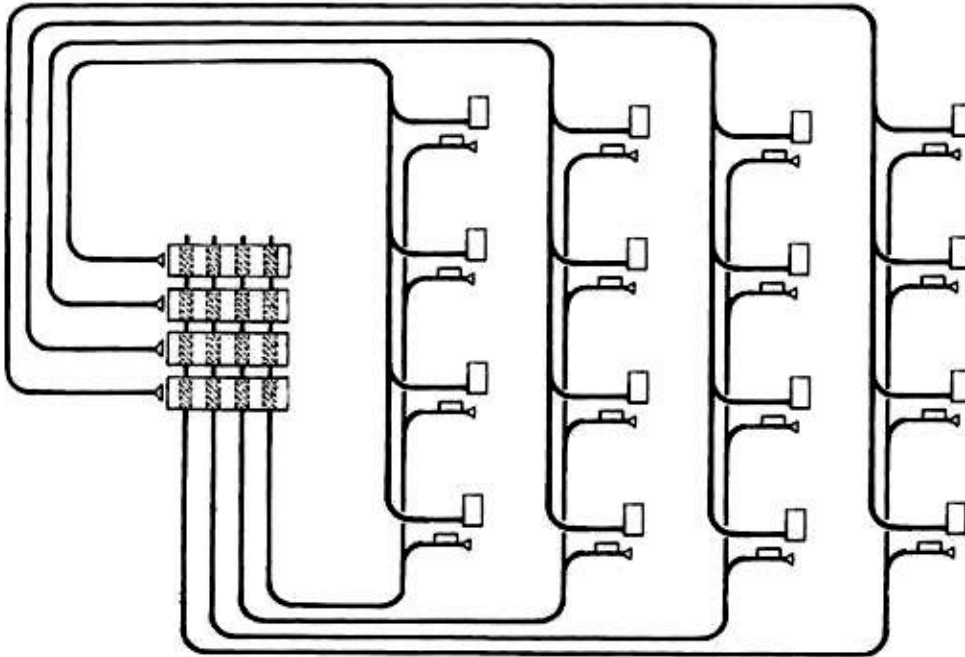

#### References

##### *Informative references*

*Attention is drawn to the following places, which may be of interest for search:*

Conveying the articles in carriers having a cross-section approximating that of the pipe or tube; Tube mail systems	<a href="#">B65G 51/04</a>
---------------------------------------------------------------------------------------------------------------------	----------------------------

**B65G 51/42**

according to indications on carriers

**Definition statement**

*This place covers:*

Illustrative example of subject matter classified in this group:

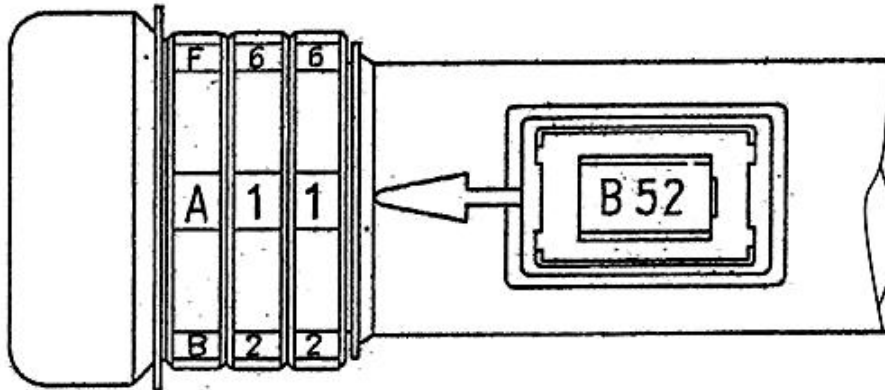
**B65G 51/44**

without mechanical contact between carriers and controllers

**Definition statement**

*This place covers:*

Illustrative example of subject matter classified in this group:

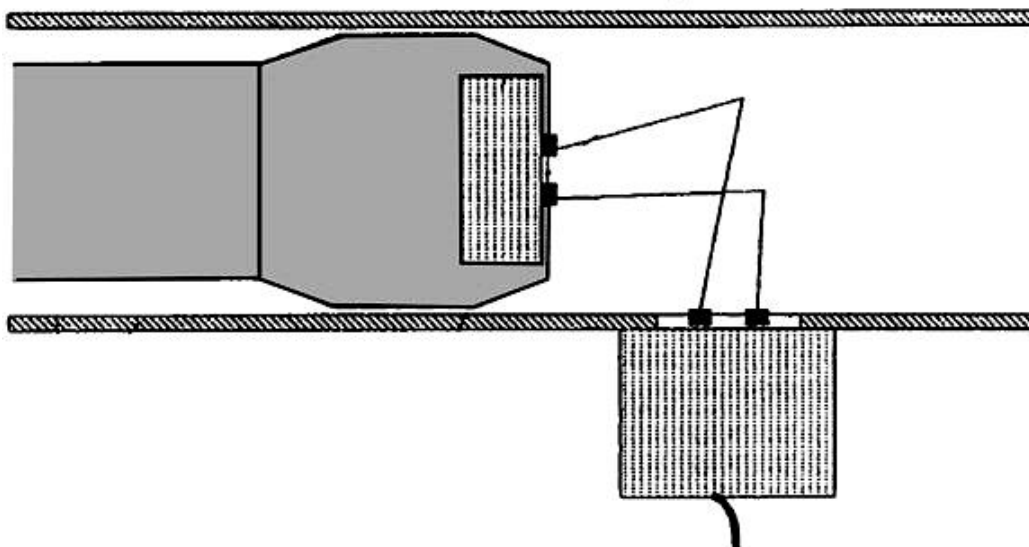

## B65G 51/46

according to separate signal systems

### Definition statement

*This place covers:*

Illustrative example of subject matter classified in this group:

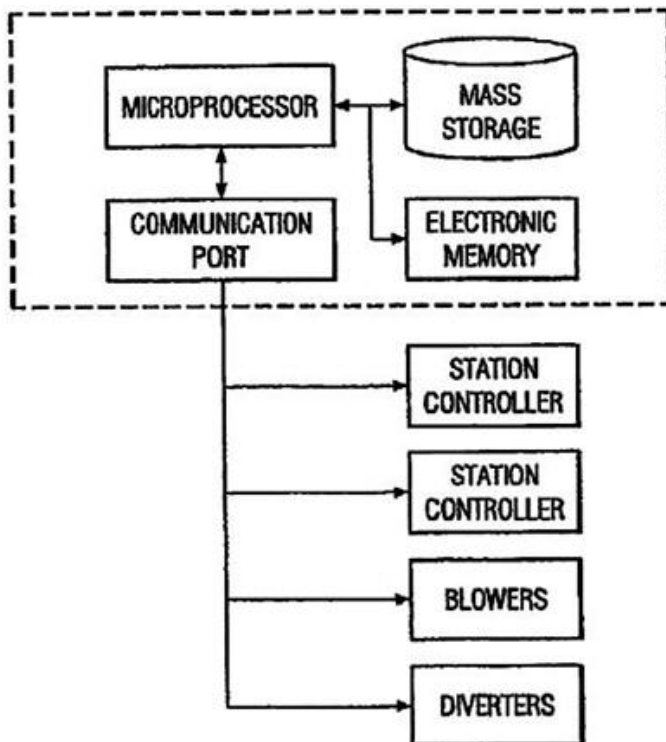
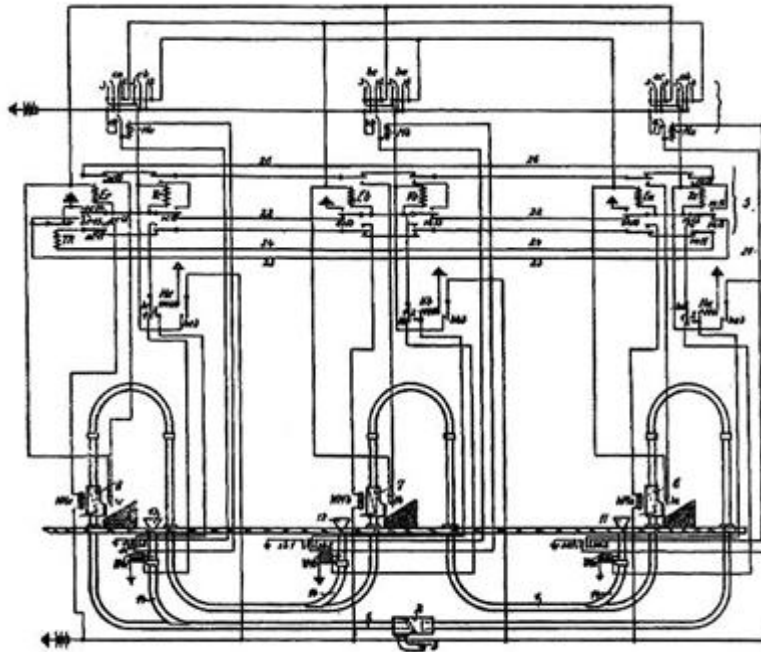

## B65G 53/00

Conveying materials in bulk through troughs, pipes or tubes by floating the materials or by flow of gas, liquid or foam

### Definition statement

*This place covers:*

Illustrative example of subject matter classified in this group:

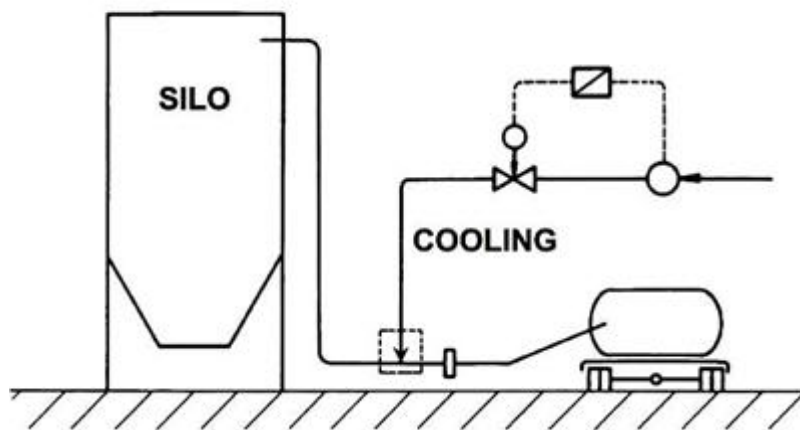

### References

#### Application-oriented references

*Examples of places where the subject matter of this place is covered when specially adapted, used for a particular purpose, or incorporated in a larger system:*

Loaders for hay or cereals	<a href="#">A01D 87/00</a>
Dredging	<a href="#">E02F</a>
Winning material out of alluvial deposits	<a href="#">E21C 45/00</a>
Hydraulic or pneumatic mine-filling-up machines	<a href="#">E21F 15/00</a>

#### Informative references

*Attention is drawn to the following places, which may be of interest for search:*

Adaptations of pipes or tubes with means for special treatment to facilitate transport	<a href="#">B65G 53/526</a>
Fluidising in connection with loading or unloading	<a href="#">B65G 69/06</a>
Indexing codes relating to handling devices, e.g. conveyors, characterised by the type of product or load being conveyed or handled	<a href="#">B65G 2201/00</a>
Machines or apparatus for treating harvested fruit, vegetables or flower bulbs in bulk, not otherwise provided for	<a href="#">A23N</a>
Discharging means for mixtures containing clay or cementitious material	<a href="#">B28C 7/16</a>
Fluidising devices facilitating filling or emptying of large containers	<a href="#">B65D 88/72</a>
Production of sucrose; apparatus specially adapted therefor	<a href="#">C13B</a>

Pumping fluid by direct contact of another fluid or by using inertia of fluid to be pumped	<a href="#">F04F</a>
Fluid dynamics, i.e. method or means for influencing the flow of gases or liquids	<a href="#">F15D</a>
Pipe-line systems	<a href="#">F17D</a>

## **B65G 53/02**

### **Floating material troughs**

#### **Definition statement**

*This place covers:*

Illustrative example of subject matter classified in this group:

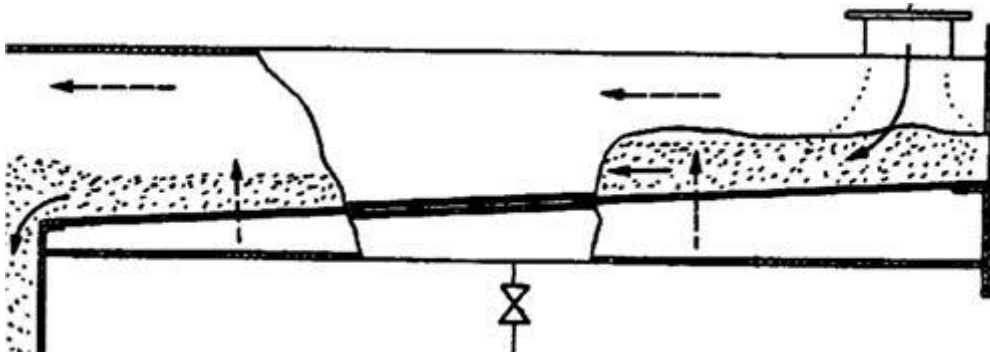

#### **References**

##### **Informative references**

*Attention is drawn to the following places, which may be of interest for search:*

Hydraulic transport of articles	<a href="#">B65G 51/01</a>
Air slides	<a href="#">B65G 53/04</a>
Fluidising devices	<a href="#">B65D 88/72</a>

**B65G 53/04****Conveying materials in bulk pneumatically through pipes or tubes; Air slides****Definition statement**

*This place covers:*

Illustrative example of subject matter classified in this group:

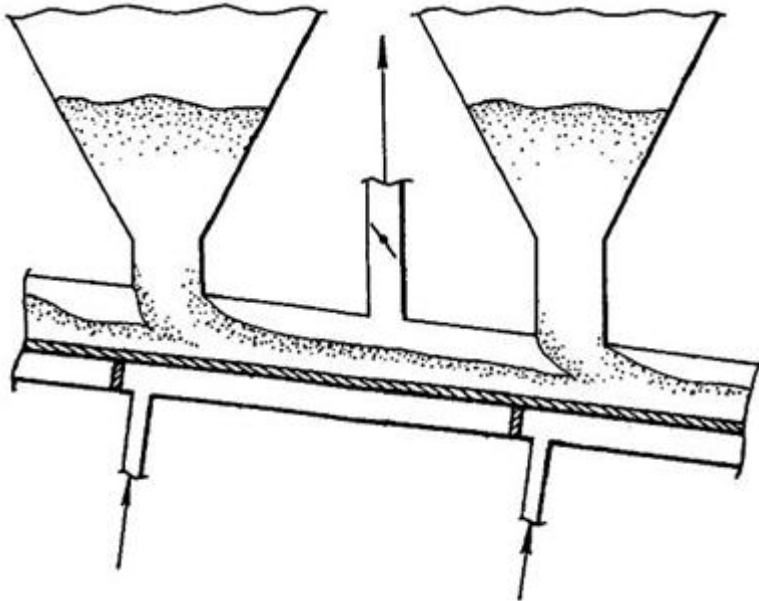
**References****Informative references**

*Attention is drawn to the following places, which may be of interest for search:*

Floating material troughs (use of air slides)	<a href="#">B65G 53/02</a>
Of ain air slide	<a href="#">B65G 53/20</a>
Seeders depositing needs in rows using pneumatic means	<a href="#">A01C 7/081</a>
Fluidising devices	<a href="#">B65D 88/72</a>
Making pig-iron in the blast furnace with injection of pulverulent coal	<a href="#">C21B 5/003</a>
Pneumatic feeding of coal to burners	<a href="#">F23K 3/02</a>



**B65G 53/06****Gas pressure systems operating without fluidisation of the materials****Definition statement**

*This place covers:*

Illustrative example of subject matter classified in this group:

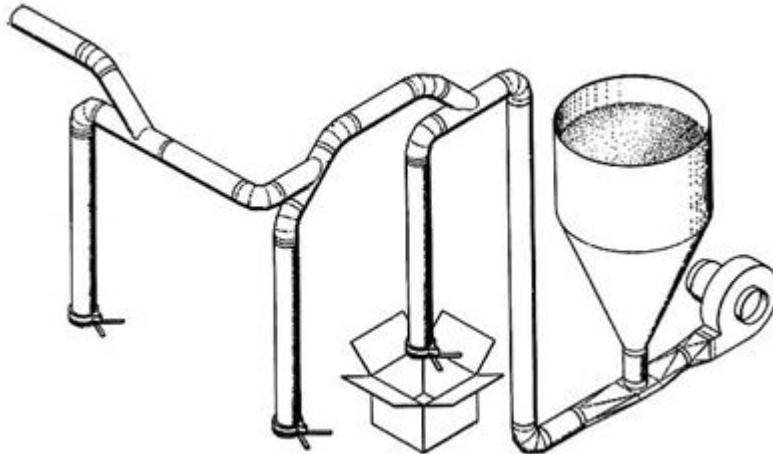
**References****Informative references**

*Attention is drawn to the following places, which may be of interest for search:*

Gathering or removal of refuse by pneumatic means e.g. by suction	<a href="#">B65F 5/005</a>
-------------------------------------------------------------------	----------------------------

**B65G 53/08****with mechanical injection of the materials, e.g. by screw****Definition statement**

*This place covers:*

Illustrative example of subject matter classified in this group:

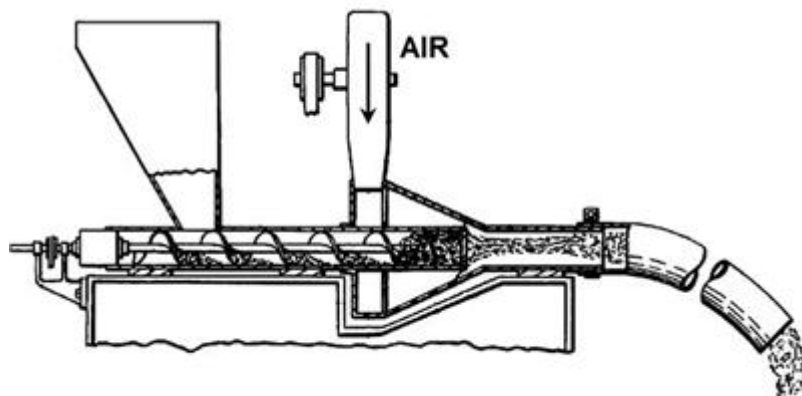

## References

### Informative references

Attention is drawn to the following places, which may be of interest for search:

Screws or like rotary conveyors	<a href="#">B65G 53/48</a>
---------------------------------	----------------------------

## B65G 53/10

with pneumatic injection of the materials by the propelling gas

### Definition statement

*This place covers:*

Illustrative example of subject matter classified in this group:

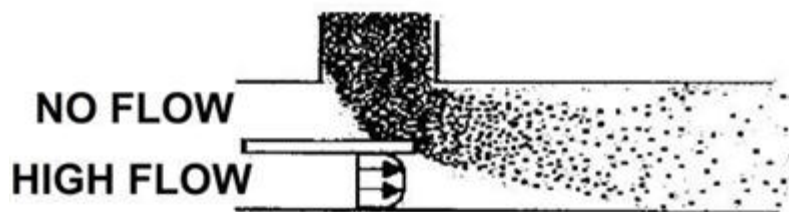

## References

### Limiting references

*This place does not cover:*

The gas flow inducing feed of the materials by suction effect	<a href="#">B65G 53/14</a>
---------------------------------------------------------------	----------------------------

## B65G 53/12

the gas flow acting directly on the materials in a reservoir

### Definition statement

*This place covers:*

Illustrative example of subject matter classified in this group:

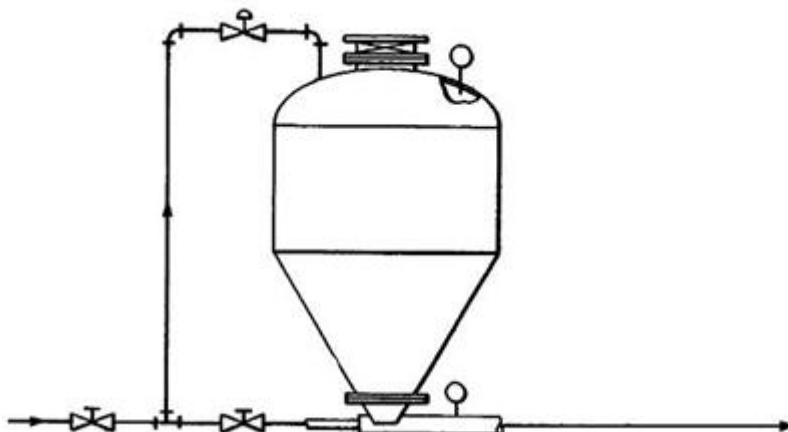

## B65G 53/14

the gas flow inducing feed of the materials by suction effect

### Definition statement

*This place covers:*

Illustrative example of subject matter classified in this group:

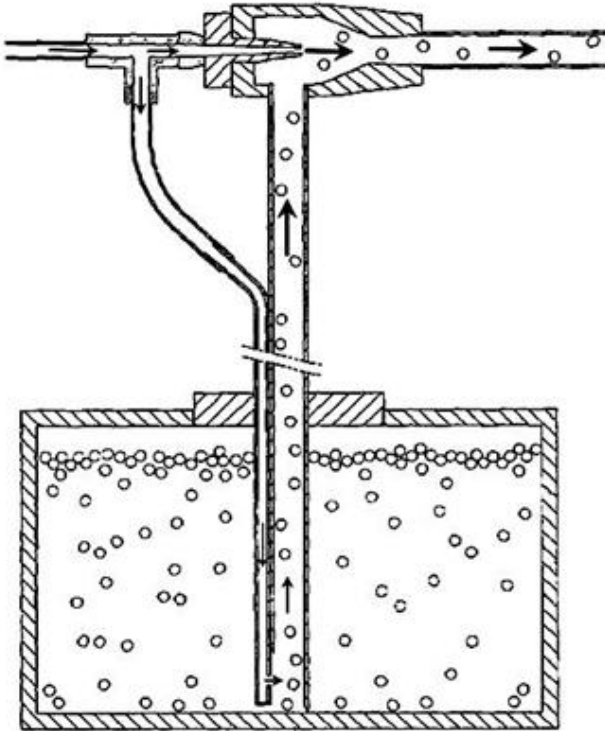

### References

#### *Informative references*

*Attention is drawn to the following places, which may be of interest for search:*

With pneumatic injection of the materials by the propelling gas	<a href="#">B65G 53/10</a>
-----------------------------------------------------------------	----------------------------

## B65G 53/16

### Gas pressure systems operating with fluidisation of the materials

#### Definition statement

*This place covers:*

Illustrative example of subject matter classified in this group:

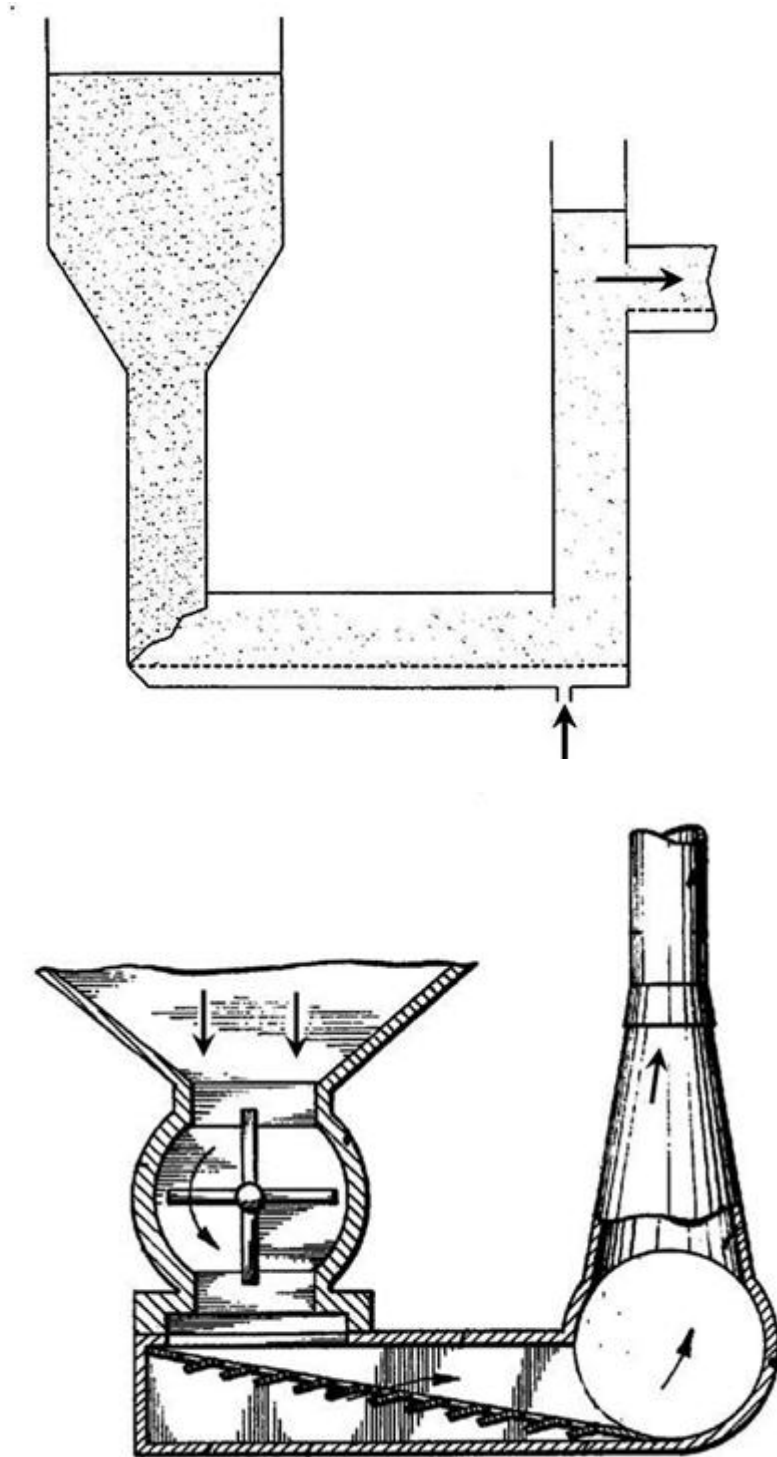

## References

### Informative references

Attention is drawn to the following places, which may be of interest for search:

Bridge preventing	<a href="#">B65D 88/70</a>
Emptying bunkers	<a href="#">B65D 88/72</a>

## B65G 53/18

through a porous wall

### Definition statement

This place covers:

Illustrative example of subject matter classified in this group:

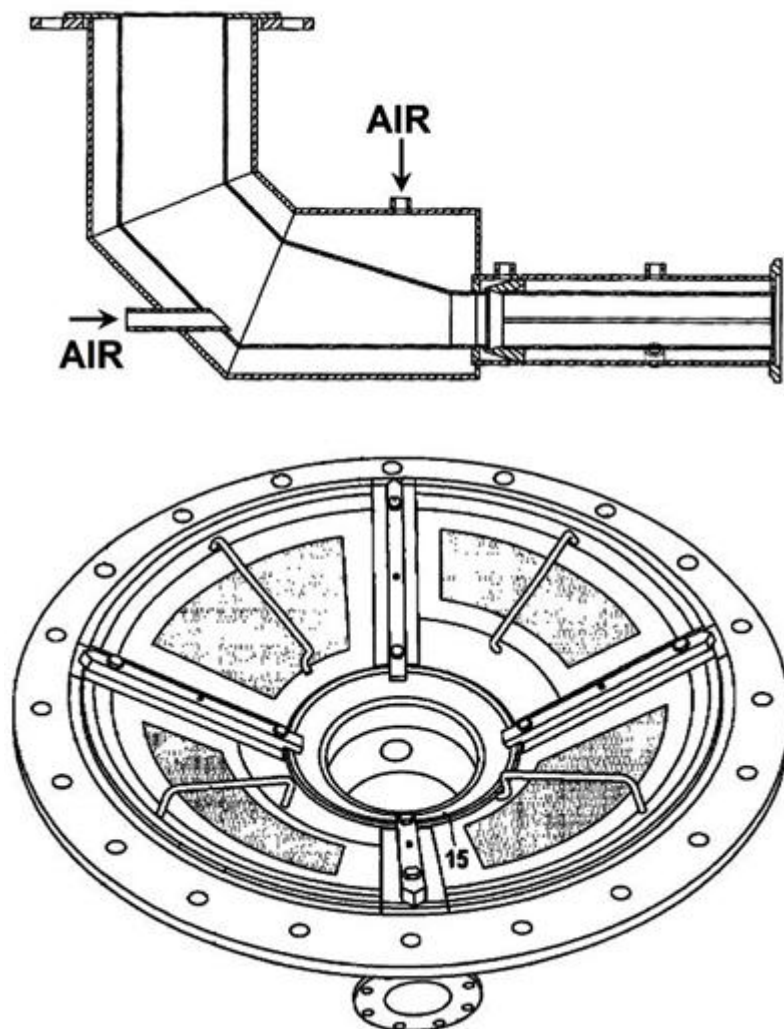

## B65G 53/20

of an air slide, e.g. a trough

### Definition statement

*This place covers:*

Illustrative example of subject matter classified in this group:

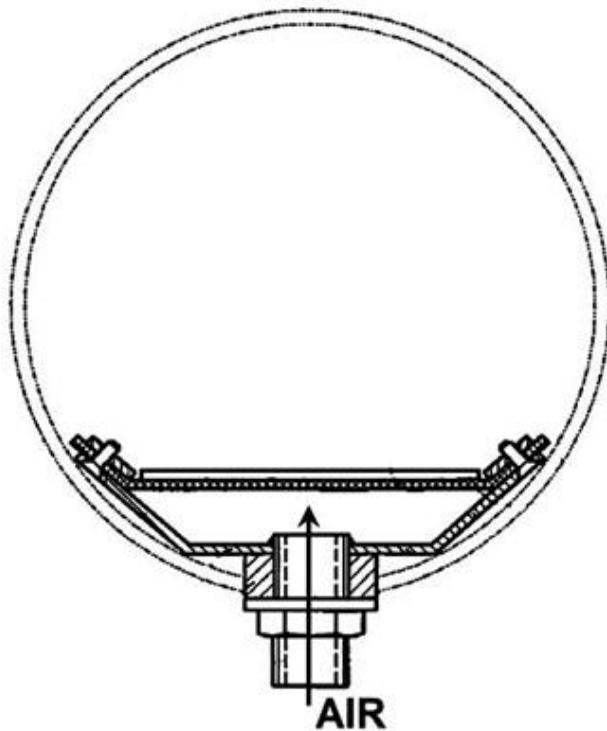
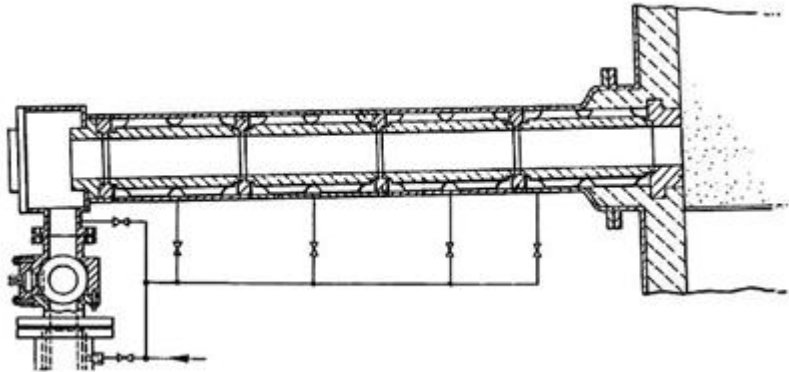

## B65G 53/22

the systems comprising a reservoir, e.g. a bunker

### Definition statement

*This place covers:*

Only when the container is also under pressure

Illustrative example of subject matter classified in this group:

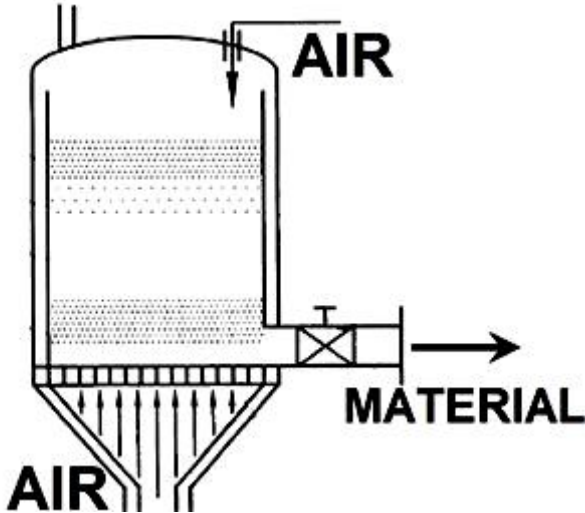

**References**

**Limiting references**

*This place does not cover:*

When the container is NOT under pressure	<a href="#">B65G 53/18</a>
------------------------------------------	----------------------------

## B65G 53/24

### Gas suction systems

#### Definition statement

*This place covers:*

Illustrative example of subject matter classified in this group:

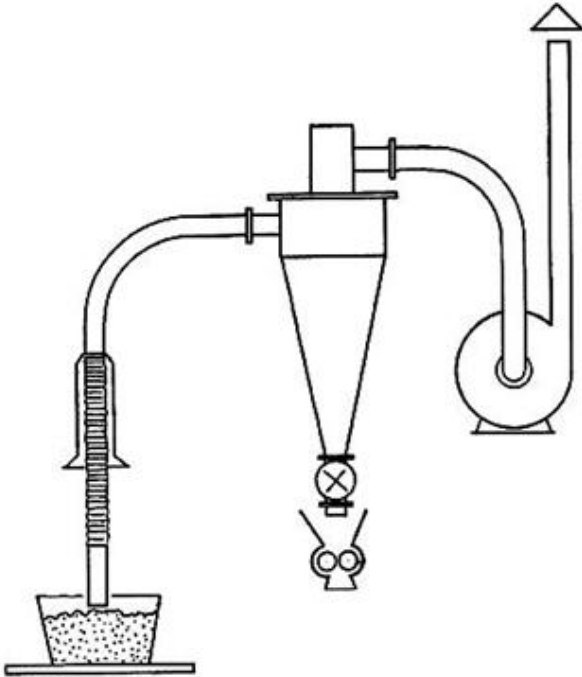

#### References

##### *Informative references*

*Attention is drawn to the following places, which may be of interest for search:*

Garbage, refuse	<a href="#">B65F 5/005</a>
-----------------	----------------------------



**B65G 53/26**

operating with fluidisation of the materials

**Definition statement**

*This place covers:*

Illustrative example of subject matter classified in this group:

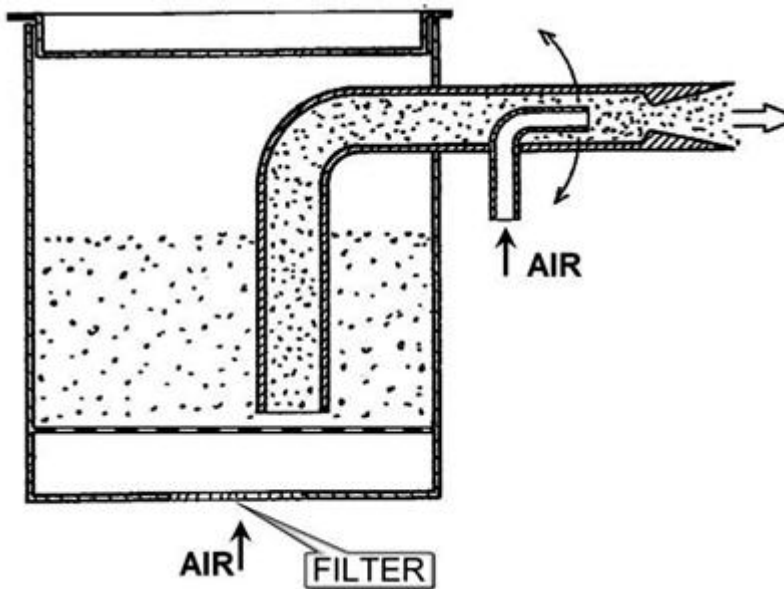
**References****Informative references**

*Attention is drawn to the following places, which may be of interest for search:*

Nozzles	<a href="#">B65G 53/42</a>
---------	----------------------------

## B65G 53/28

Systems utilising a combination of gas pressure and suction (inducing feed of the materials by suction in gas pressure systems [B65G 53/14](#))

### Definition statement

*This place covers:*

Illustrative example of subject matter classified in this group:

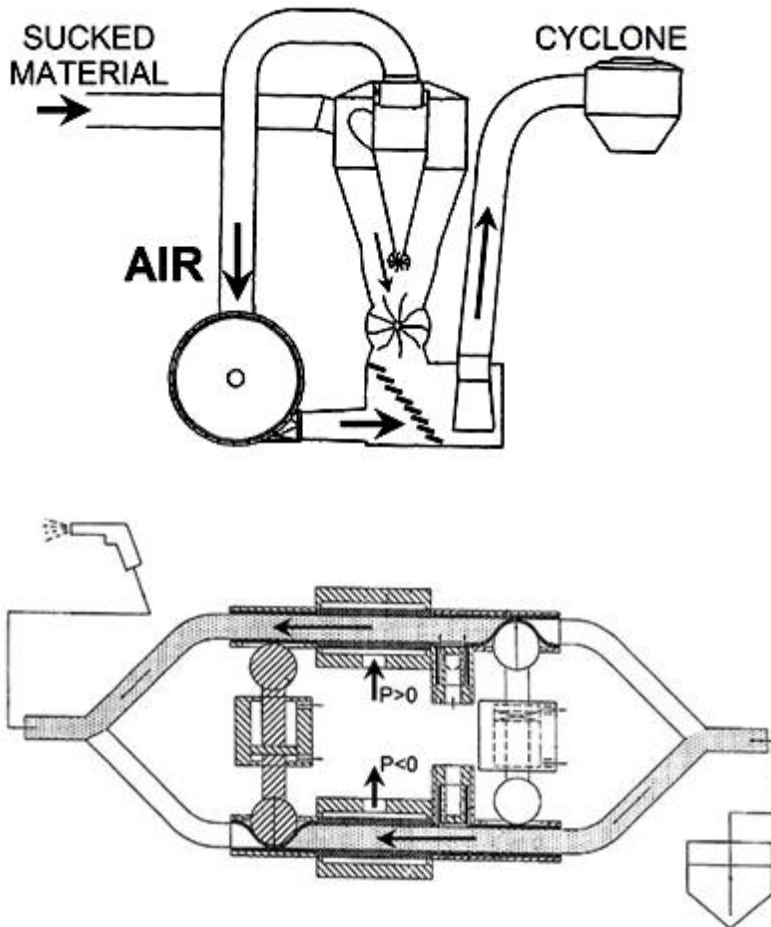

## B65G 53/30

### Conveying materials in bulk through pipes or tubes by liquid pressure

#### Definition statement

*This place covers:*

Illustrative example of subject matter classified in this group:

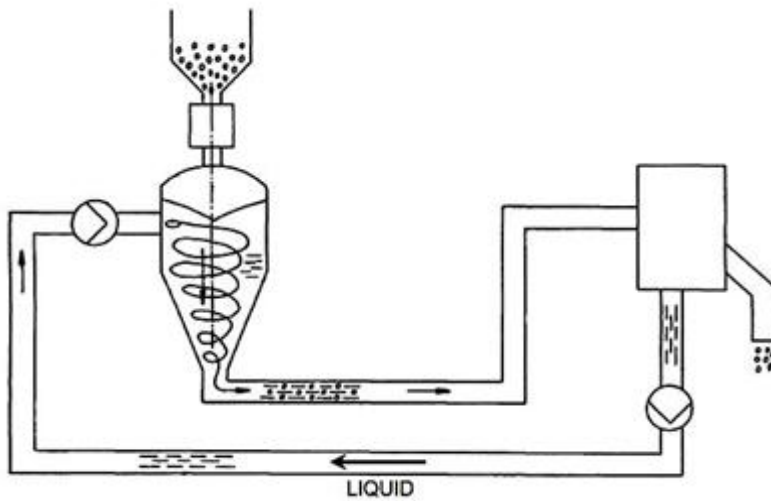

#### References

##### *Informative references*

*Attention is drawn to the following places, which may be of interest for search:*

Transport of slurry, fish	<a href="#">A01K 63/00</a>
---------------------------	----------------------------

## B65G 53/32

Conveying concrete, e.g. for distributing same at building sites (mixing concrete on or by conveyors [B28C 5/34](#))

### Definition statement

*This place covers:*

Illustrative example of subject matter classified in this group:

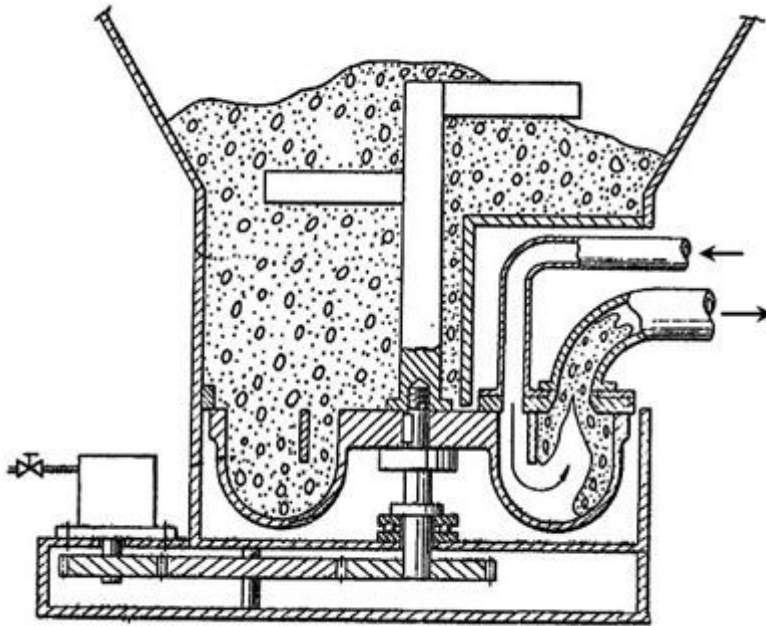

## B65G 53/34

### Details

#### Definition statement

*This place covers:*

Details of pneumatic conveying systems for bulk material, examples:

- driving unit for pneumatic conveyors;
- safety means;
- cooling;
- heating;
- cleaning;
- preventing dust;
- noise damping;
- inert gas use;
- etc.

Illustrative example of subject matter classified in this group:

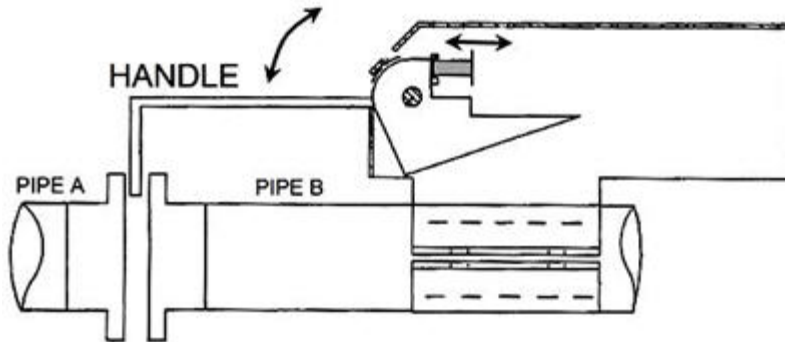

## **B65G 53/36**

Arrangements of containers (hoppers [B65D 3/06](#); containers in general [B65D](#))

### **Definition statement**

*This place covers:*

Illustrative example of subject matter classified in this group:

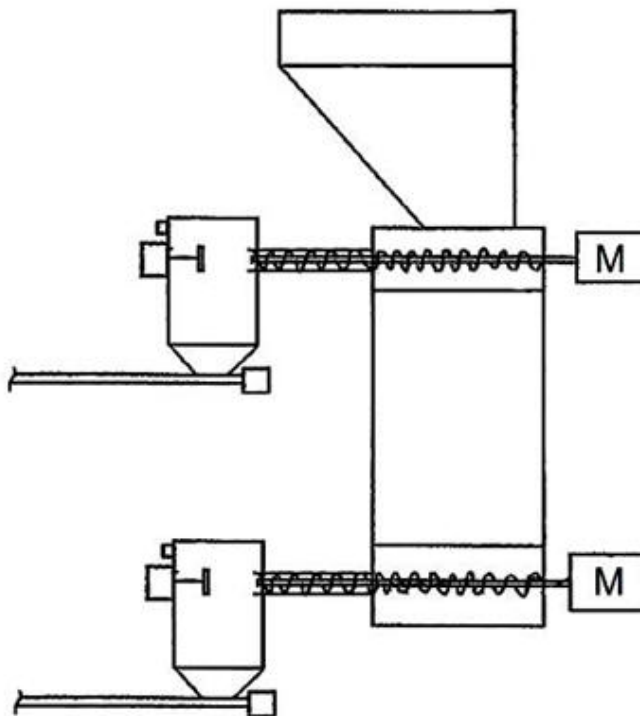

### **References**

#### **Informative references**

Attention is drawn to the following places, which may be of interest for search:

Feeding to the line	<a href="#">B65G 53/4691</a>
---------------------	------------------------------

**B65G 53/38**

**Modification of material containing walls to facilitate fluidisation (hoppers with walls modified for fluidisation of contents [B65D 88/72](#))**

**References****Informative references**

*Attention is drawn to the following places, which may be of interest for search:*

Gas pressure with fluidization	<a href="#">B65G 53/18</a>
Gas suction with fluidization	<a href="#">B65G 53/26</a>

**B65G 53/40**

**Feeding or discharging devices**

**Definition statement**

*This place covers:*

Illustrative example of subject matter classified in this group:

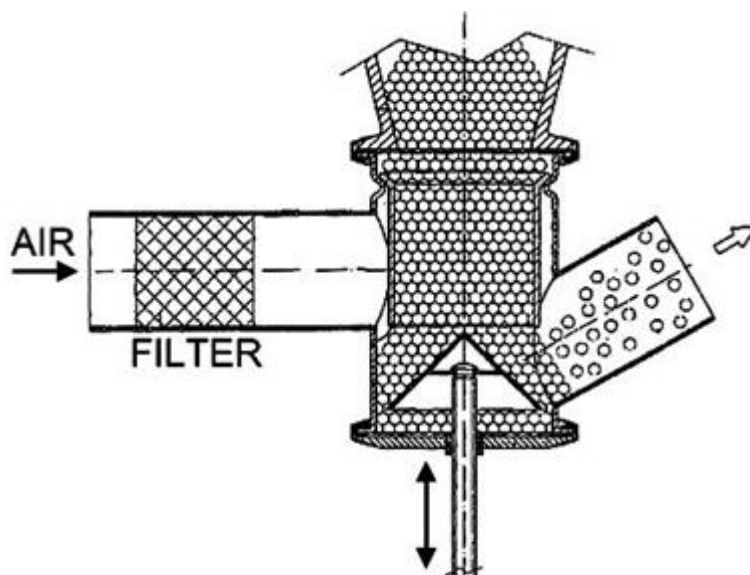

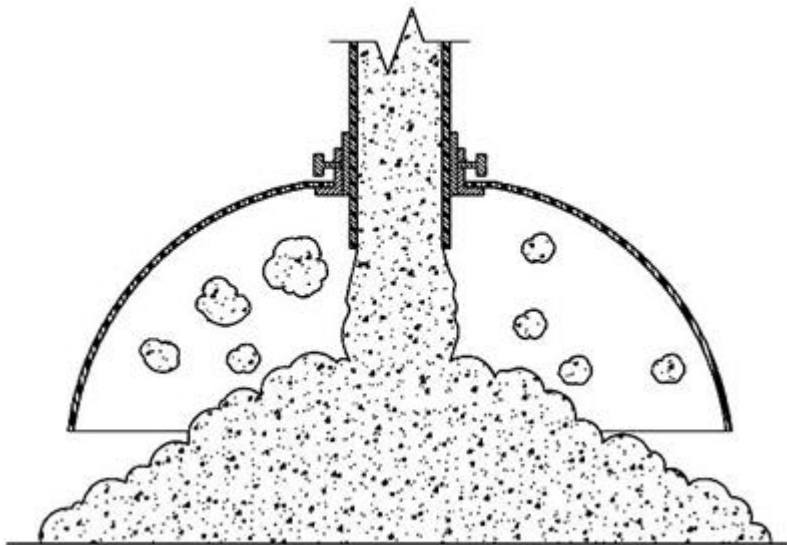

**References**

**Informative references**

Attention is drawn to the following places, which may be of interest for search:

Gate control	<a href="#">B65G 53/46</a>
Pneumatic conveyor control	<a href="#">B65G 53/66</a>
Spreading out	<a href="#">B65G 69/0491</a>

## B65G 53/42

### Nozzles

#### Definition statement

*This place covers:*

Illustrative example of subject matter classified in this group:

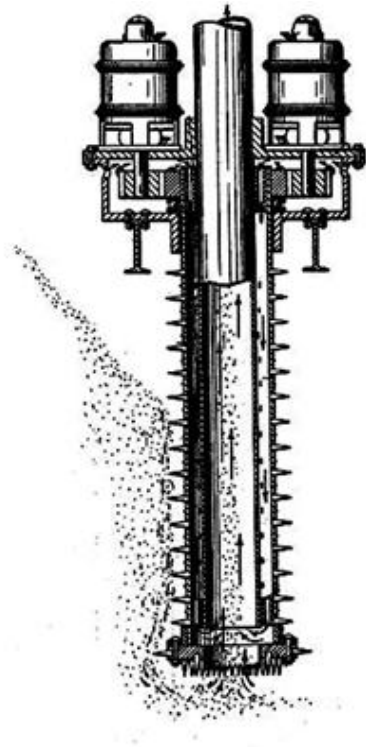
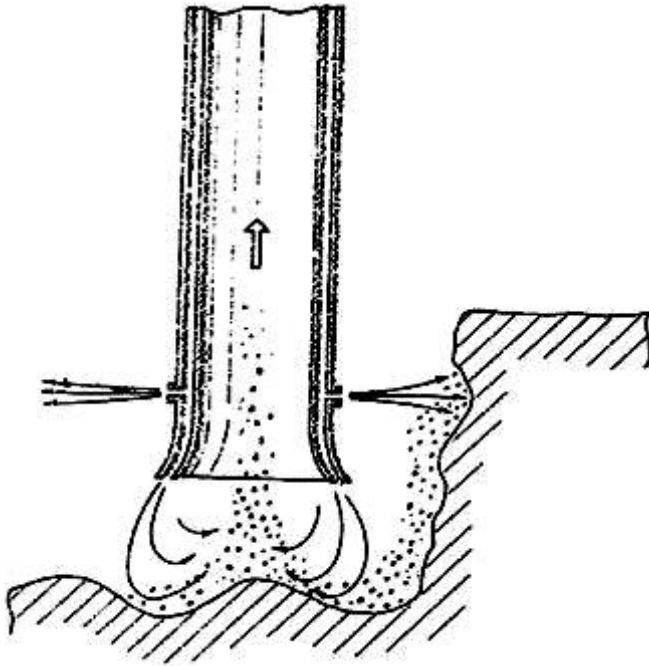



## References

### *Informative references*

Attention is drawn to the following places, which may be of interest for search:

Nozzles in general	<a href="#">B05B</a>
--------------------	----------------------

## B65G 53/44

### Endless conveyors

### Definition statement

*This place covers:*

Illustrative example of subject matter classified in this group:

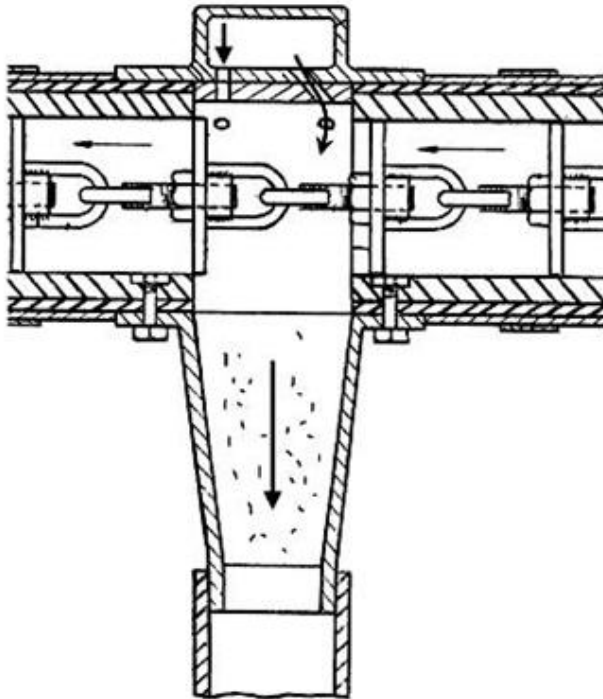

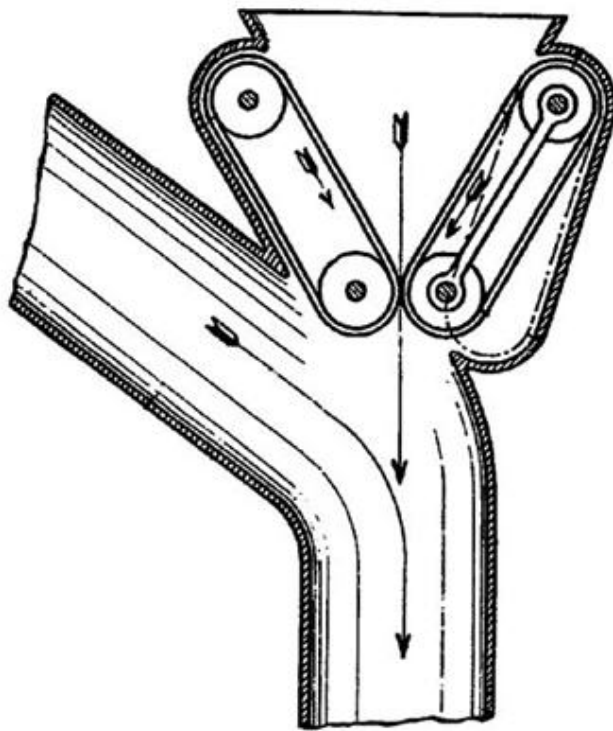

## B65G 53/46

Gates or sluices, e.g. rotary wheels

### Definition statement

*This place covers:*

Illustrative example of subject matter classified in this group:

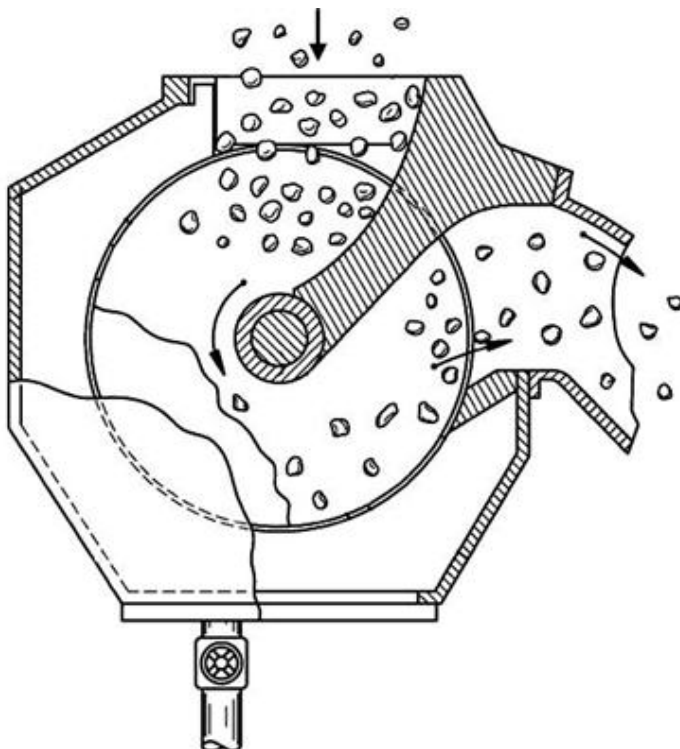

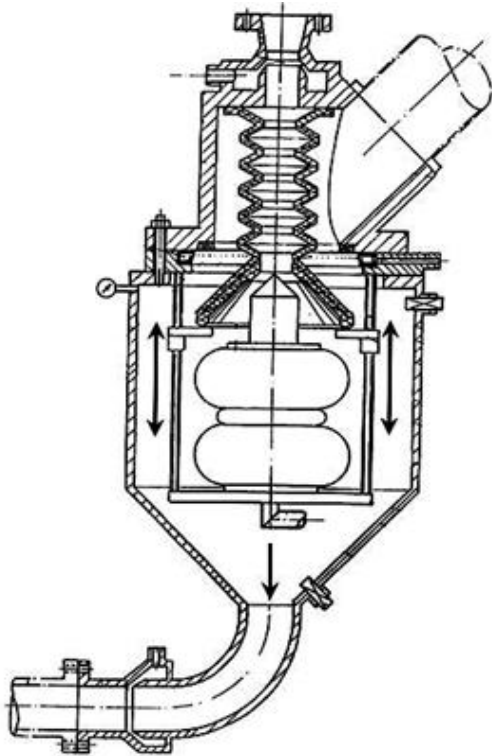

**B65G 53/4616**

{with axis of turning parallel to flow}

**Definition statement**

*This place covers:*

Illustrative example of subject matter classified in this group:

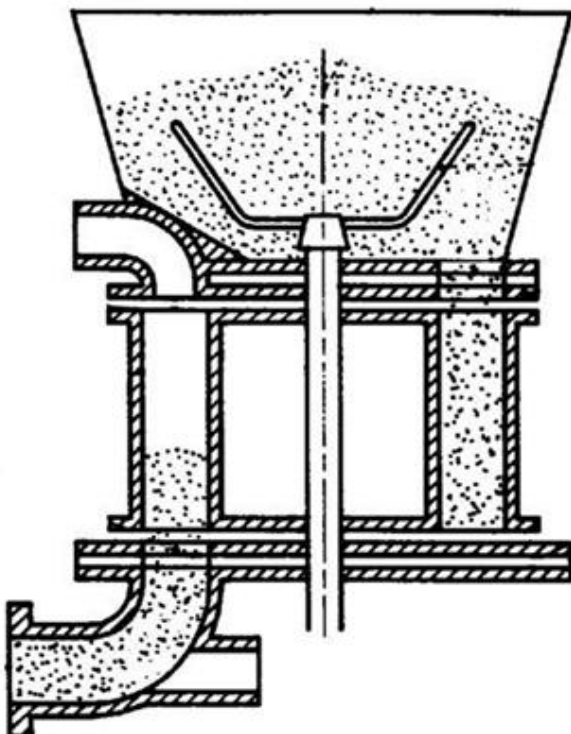

**B65G 53/4625**

{with axis of turning perpendicular to flow}

**References****Informative references**

Attention is drawn to the following places, which may be of interest for search:

Gates or sluices, e.g. rotary wheels	<a href="#">B65G 53/46</a>
--------------------------------------	----------------------------

**B65G 53/4633**

{the element having pockets, rotated from charging position to discharging position, i.e. discrete flow}

**Definition statement**

*This place covers:*

Illustrative example of subject matter classified in this group:

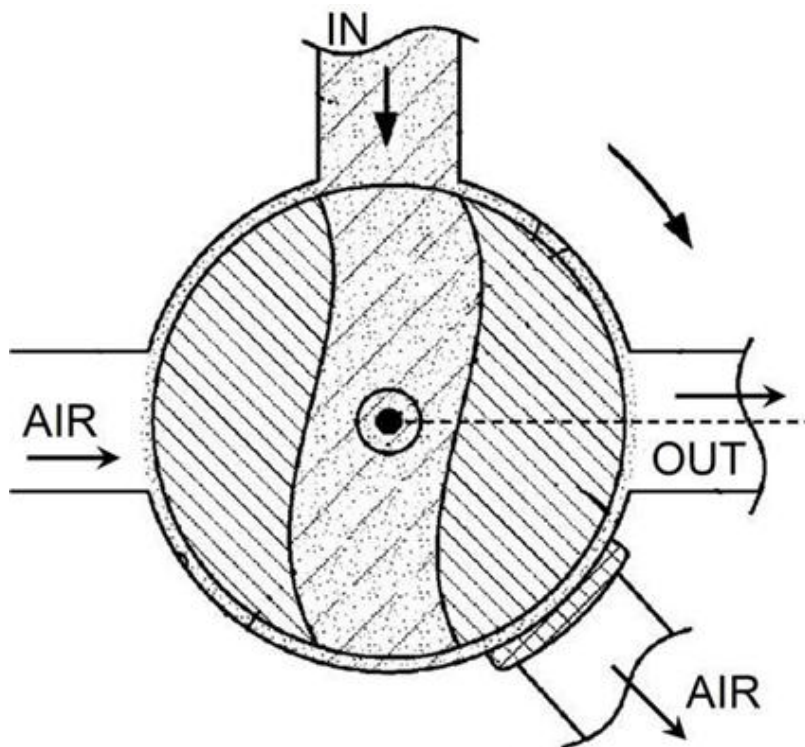

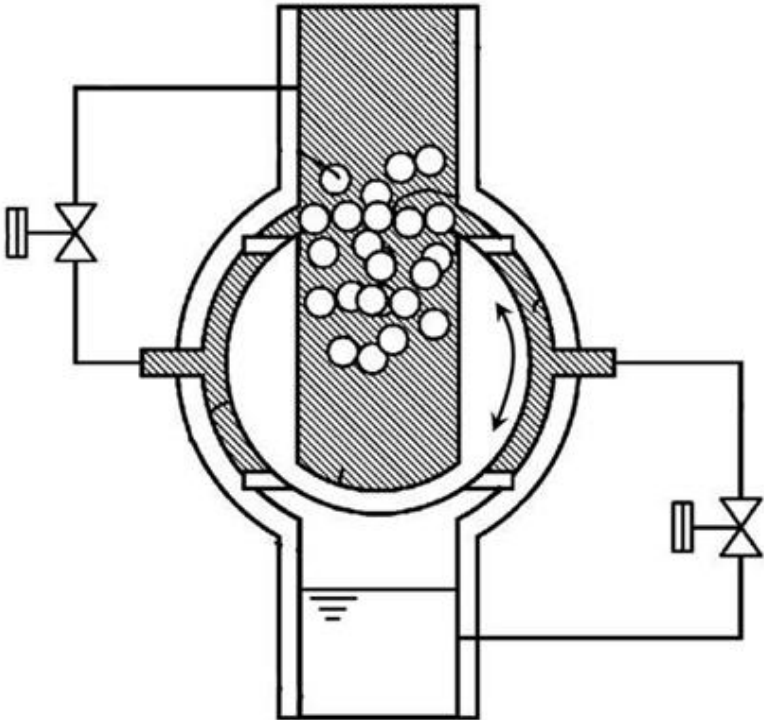
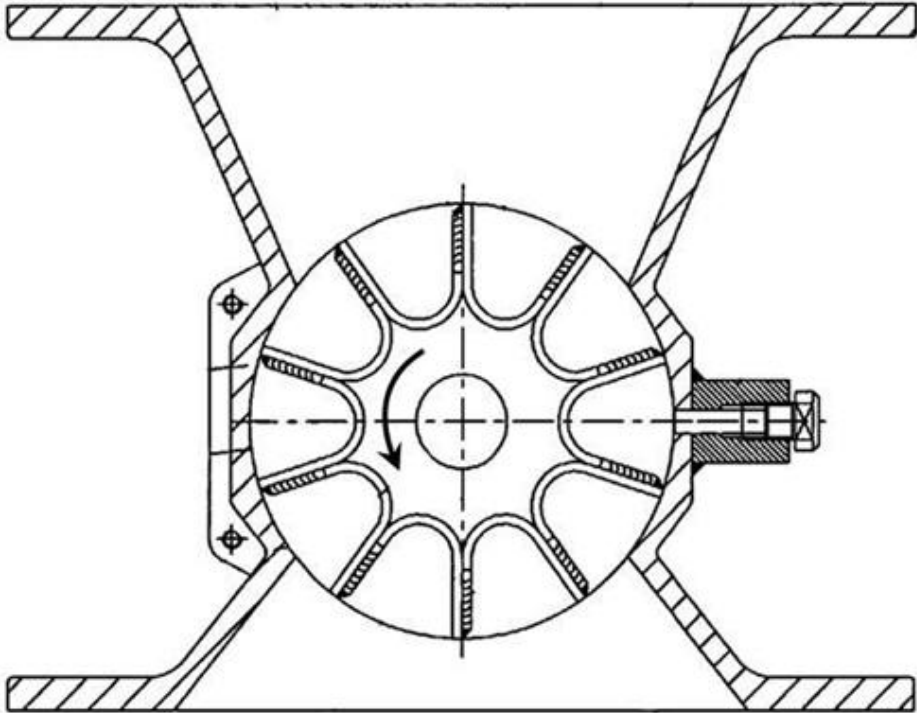

**B65G 53/4641**

{with means for clearing out the pockets}

**Definition statement**

*This place covers:*

Illustrative example of subject matter classified in this group:

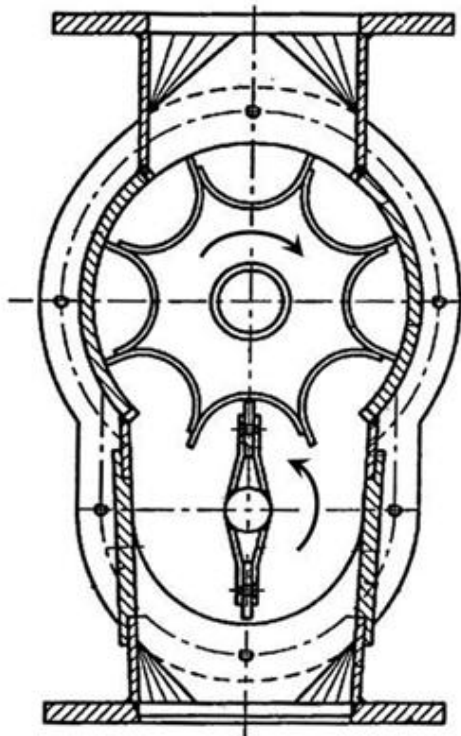
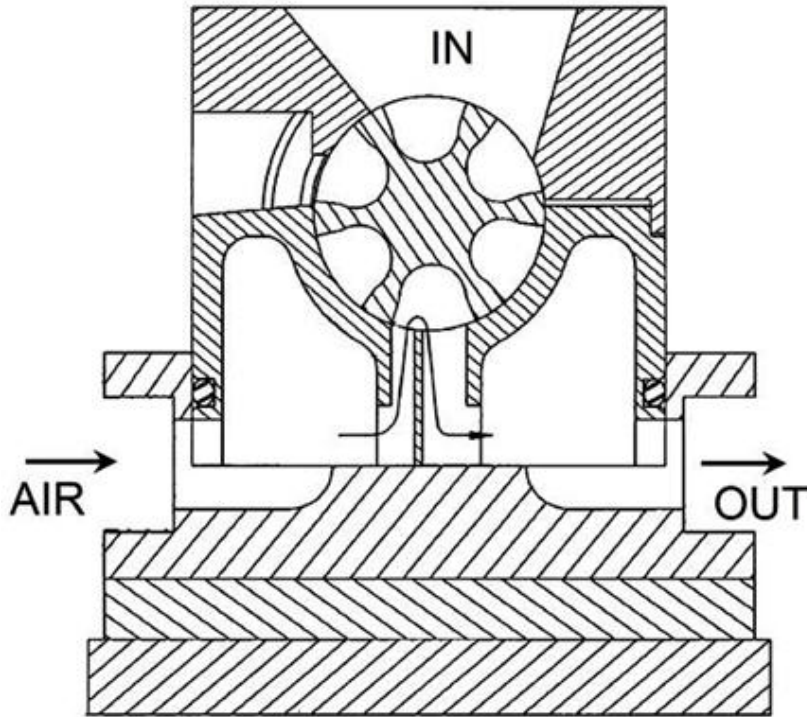

## B65G 53/465

{with a closable outlet}

### Definition statement

*This place covers:*

Illustrative example of subject matter classified in this group:

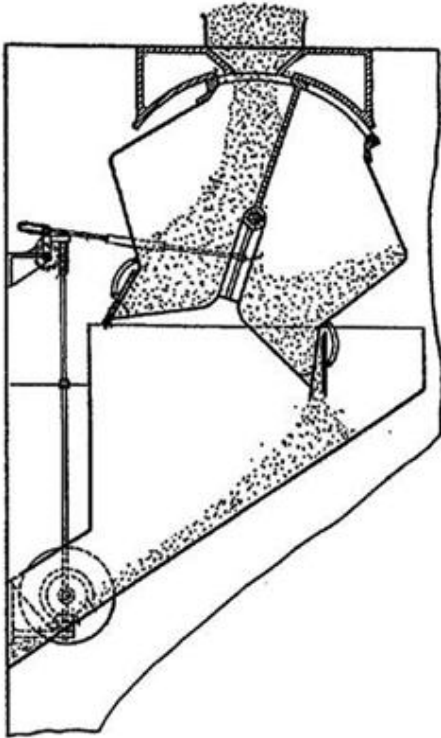



**B65G 53/4658**

{the element having passages simultaneously connectable to both inlet and outlet ports}

**Definition statement**

*This place covers:*

Illustrative example of subject matter classified in this group:

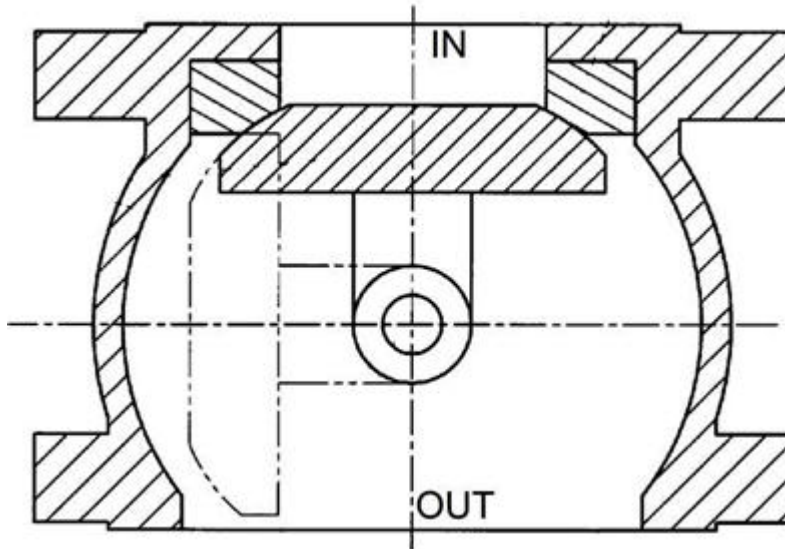
**B65G 53/4666**

{with axis of turning neither parallel nor perpendicular to flow, i.e. mixed flow}

**Definition statement**

*This place covers:*

Illustrative example of subject matter classified in this group:

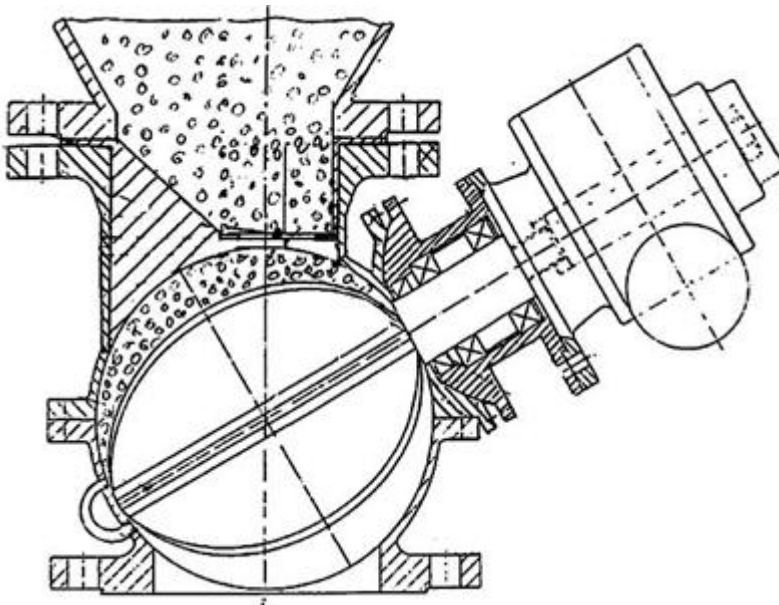



## B65G 53/4675

{with flexible wall parts, e.g. peristaltic devices}

### Definition statement

*This place covers:*

Illustrative example of subject matter classified in this group:

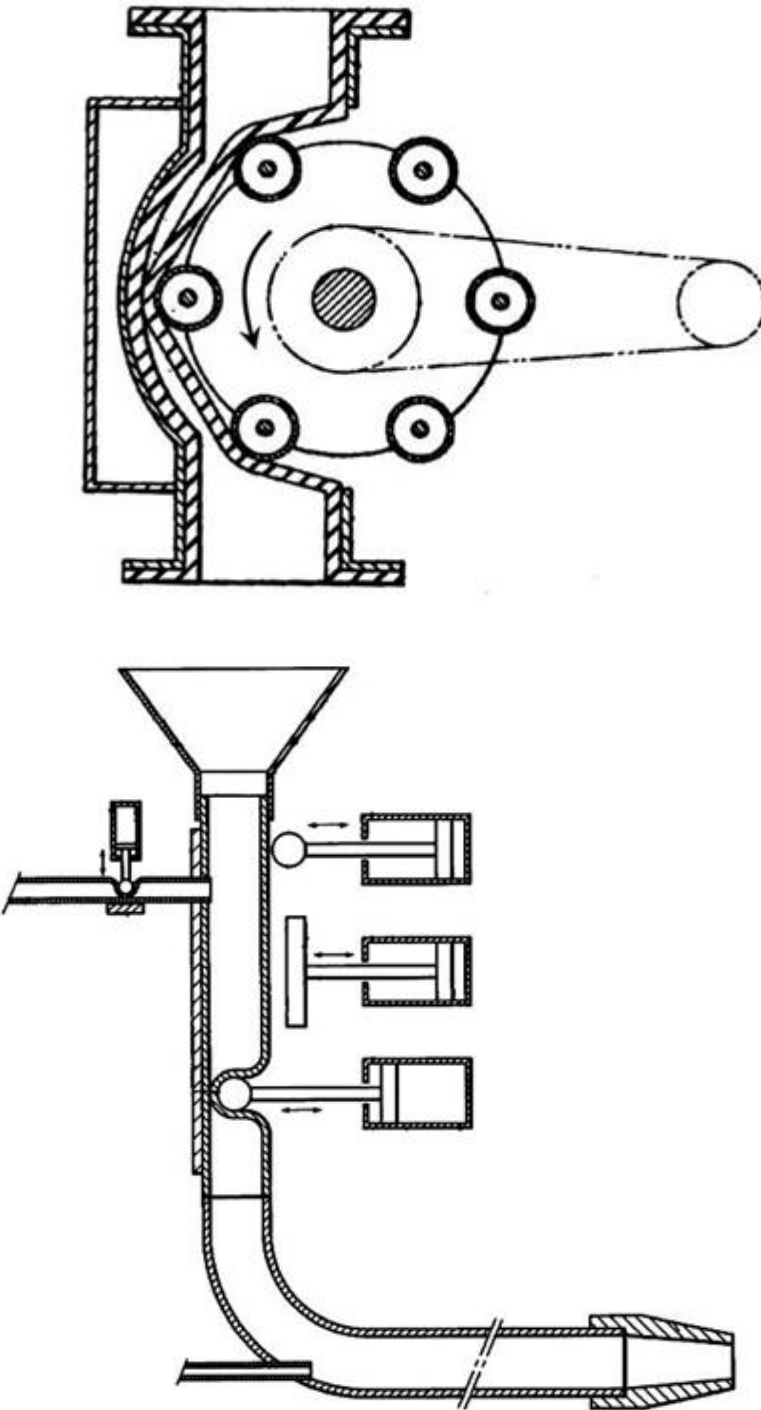

**B65G 53/4683**

{with a reciprocating mover acting directly on material}

**Definition statement**

*This place covers:*

When the material is displaced by the reciprocating device

Illustrative example of subject matter classified in this group:

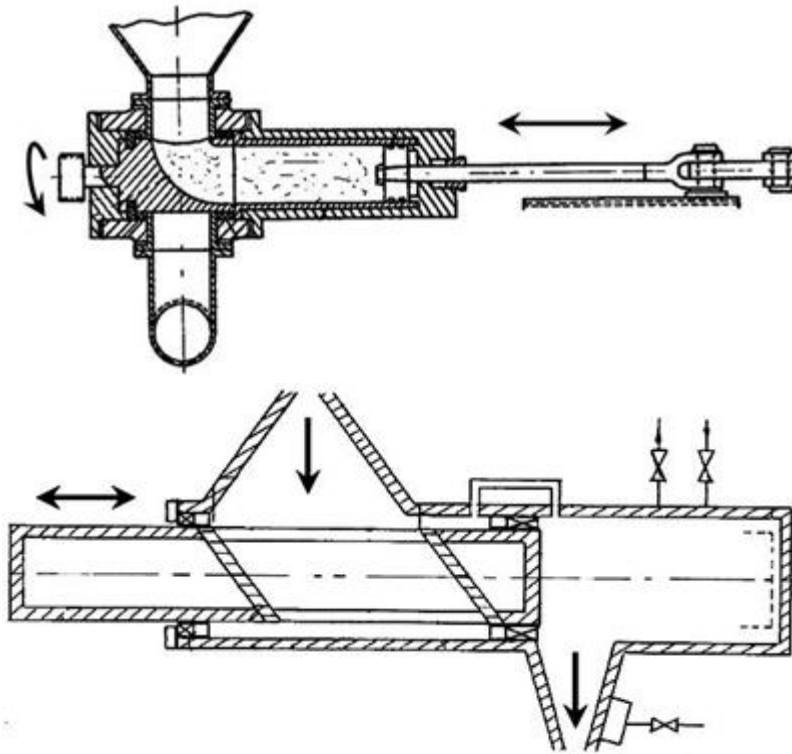
**References****Informative references**

Attention is drawn to the following places, which may be of interest for search:

Shut-off valve	<a href="#">B65G 53/46</a>
----------------	----------------------------

**B65G 53/4691**

{of air-lock type, i.e. at least two valves opening asynchronously}

**Definition statement**

*This place covers:*

Illustrative example of subject matter classified in this group:

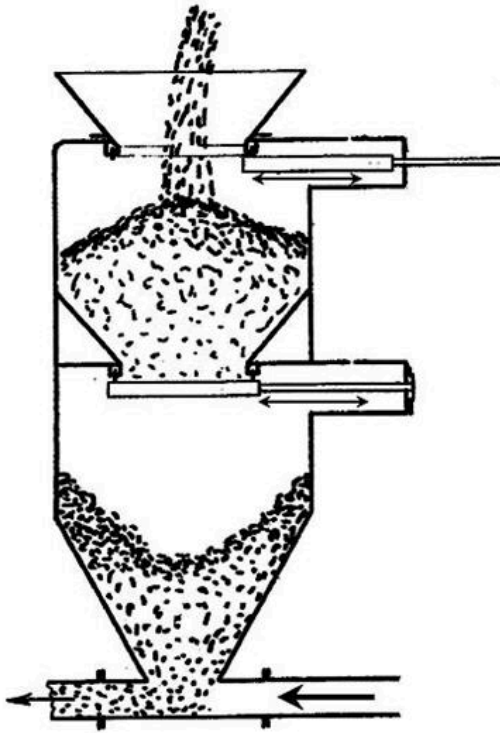
**References****Informative references**

Attention is drawn to the following places, which may be of interest for search:

Valves	<a href="#">B65G 53/46</a>
--------	----------------------------

## B65G 53/48

### Screws or like rotary conveyors

#### Definition statement

*This place covers:*

Illustrative example of subject matter classified in this group:

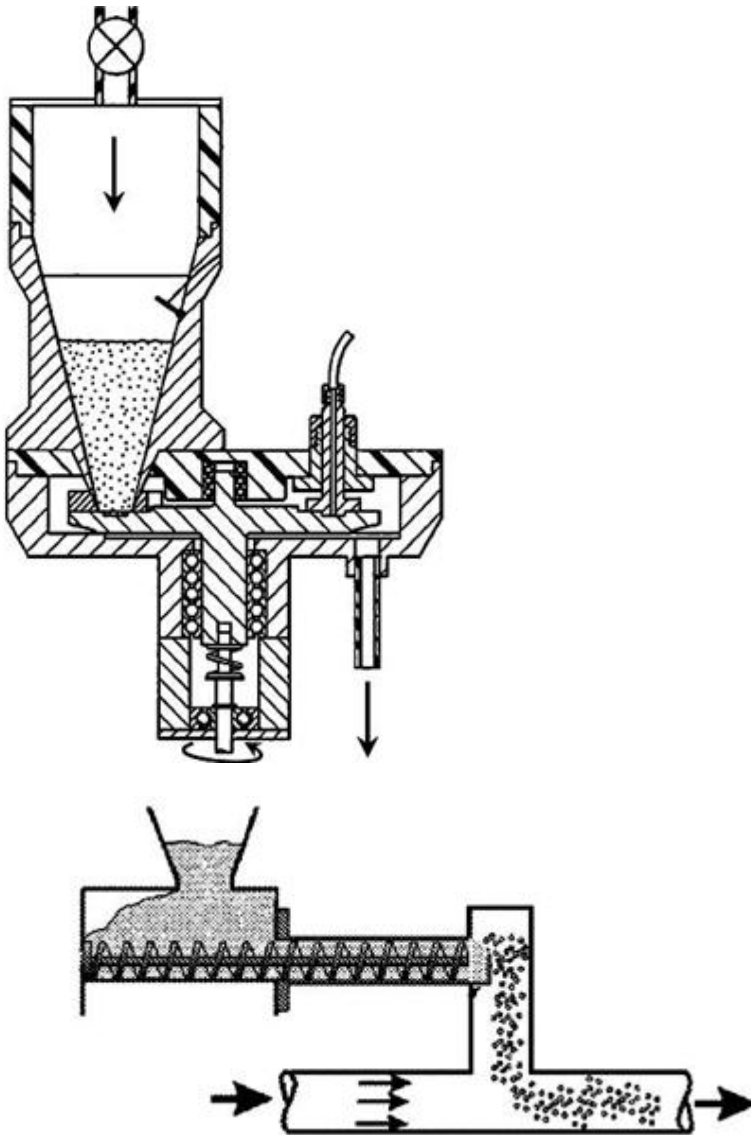

#### References

##### Informative references

*Attention is drawn to the following places, which may be of interest for search:*

Screw or rotary spiral conveyors	<a href="#">B65G 33/00</a>
With mechanical injection of the materials, e.g. by screw	<a href="#">B65G 53/08</a>
Gates or sluices, e.g. rotary wheels	<a href="#">B65G 53/46</a>

## B65G 53/50

Pneumatic devices (incorporated in nozzles [B65G 53/42](#))

### Definition statement

*This place covers:*

Illustrative example of subject matter classified in this group:

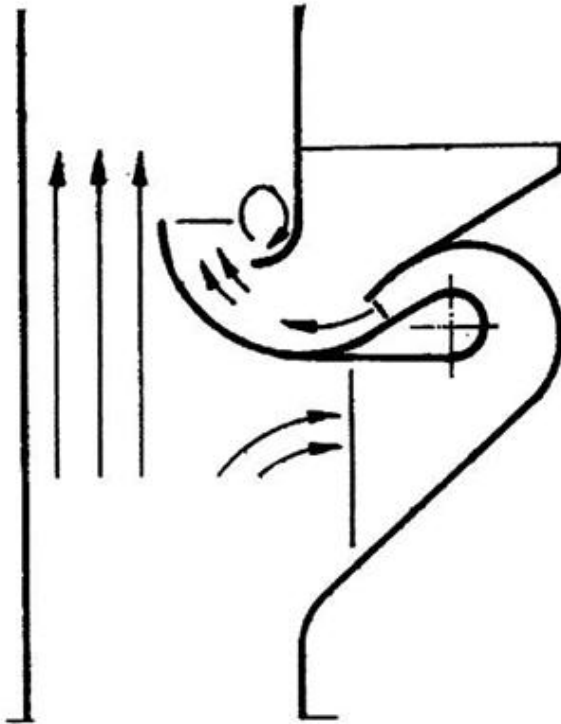

### References

#### Informative references

Attention is drawn to the following places, which may be of interest for search:

With pneumatic injection of the materials, e.g. by screw	<a href="#">B65G 53/10</a>
The gas flow inducing feed of the materials by suction effect	<a href="#">B65G 53/14</a>
Nozzles	<a href="#">B65G 53/42</a>

## B65G 53/52

Adaptations of pipes or tubes

### Definition statement

*This place covers:*

The pipes relate only to pneumatic conveyor and examples are:

- connecting pipes;
- pivoting pipes;
- telescopic pipes;
- etc.

NON pneumatic conveyors

Illustrative example of subject matter classified in this group:

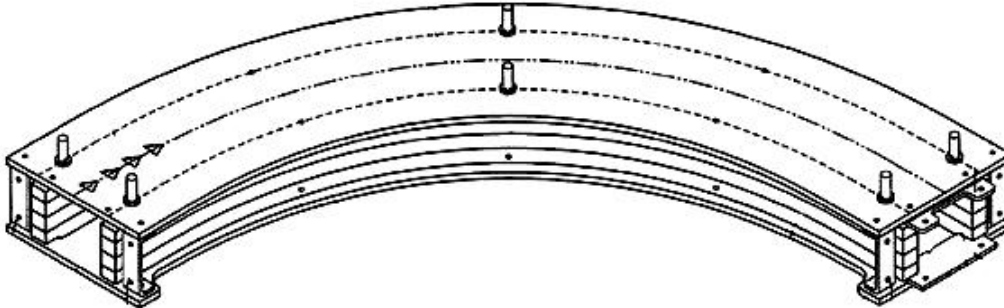

## References

### Informative references

Attention is drawn to the following places, which may be of interest for search:

Pipe; joints or fittings for pipes; supports for pipes, cables or protective tubing; means of thermal insulation in general	<a href="#">F16L</a>
-----------------------------------------------------------------------------------------------------------------------------	----------------------

## B65G 53/521

{means for preventing the accumulation or for removal of deposits (preventing accumulation in pipes in general [F16L 55/24](#))}

### Definition statement

This place covers:

Illustrative example of subject matter classified in this group:

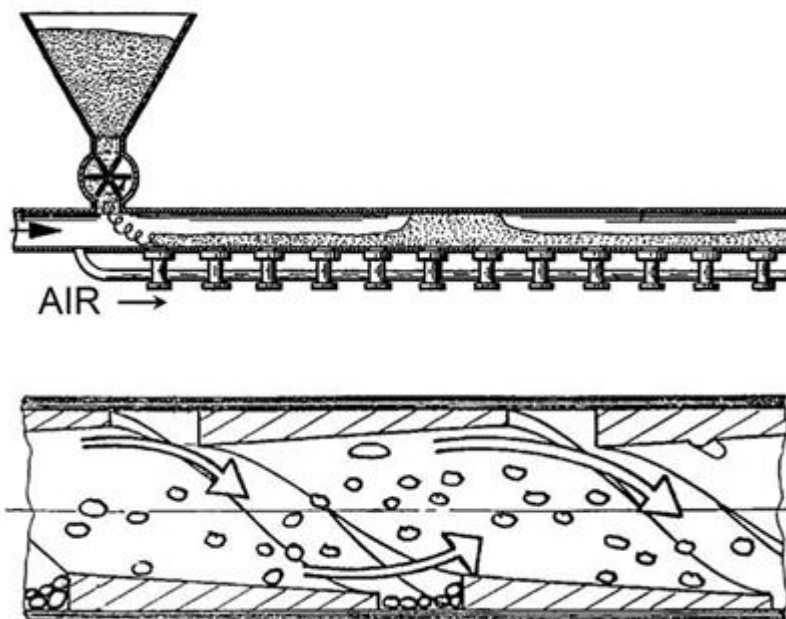

## References

### *Informative references*

*Attention is drawn to the following places, which may be of interest for search:*

Devices for accelerating or decelerating flow of the materials; use of pressure generators	<a href="#">B65G 53/58</a>
--------------------------------------------------------------------------------------------	----------------------------

## **B65G 53/523**

**{Wear protection}**

### **Definition statement**

*This place covers:*

Illustrative example of subject matter classified in this group:

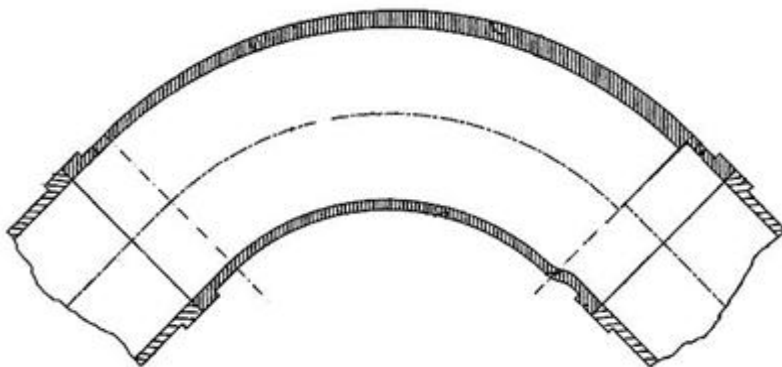

## B65G 53/525

{for conveyance in plug-form}

### Definition statement

*This place covers:*

Illustrative example of subject matter classified in this group:

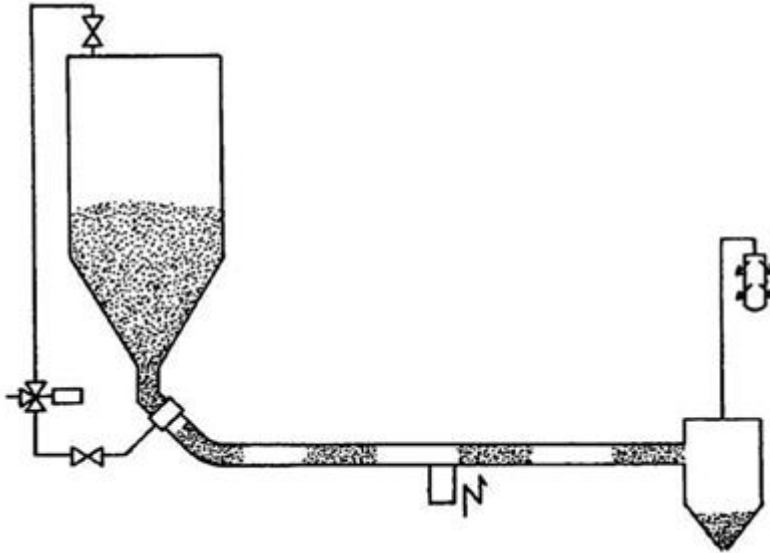



**B65G 53/526**

{with means for special treatment to facilitate transport}

**Definition statement**

*This place covers:*

Illustrative example of subject matter classified in this group:

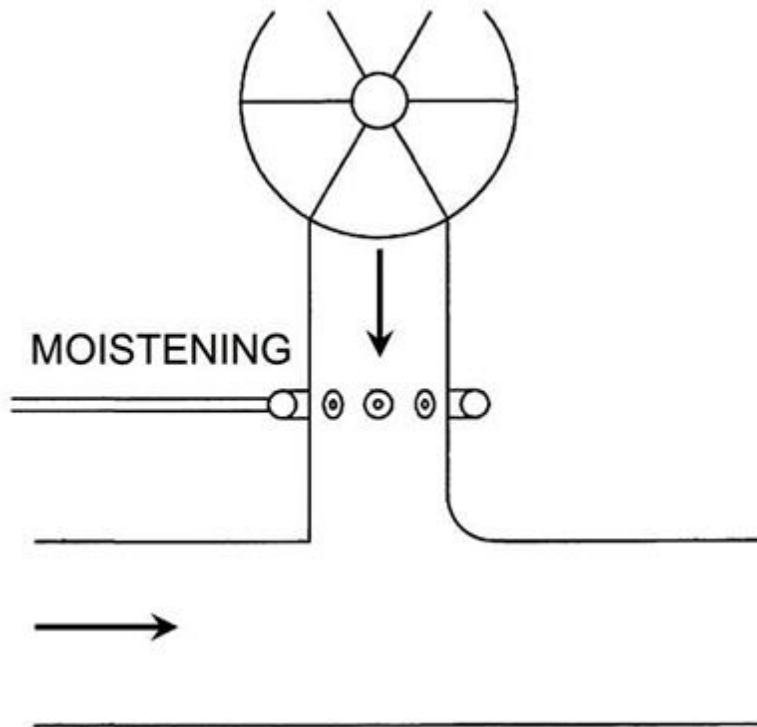
**B65G 53/528**

{Flux combining or dividing arrangements ([B65G 53/56](#) takes precedence)}

**Definition statement**

*This place covers:*

Illustrative example of subject matter classified in this group:

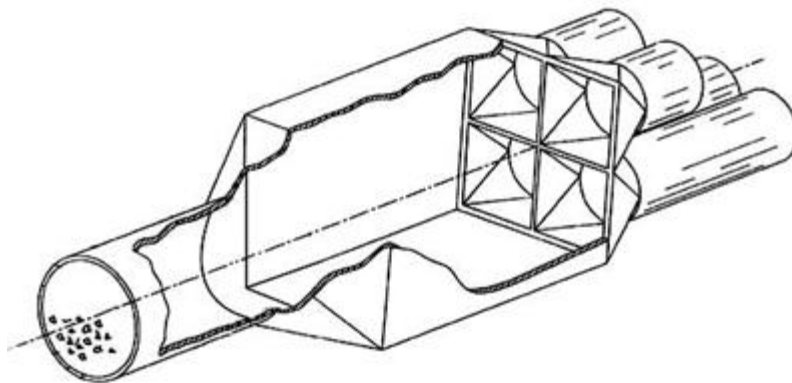

## References

### Limiting references

*This place does not cover:*

Switches	<a href="#">B65G 53/56</a>
----------	----------------------------

### Informative references

*Attention is drawn to the following places, which may be of interest for search:*

Transferring materials in bulk from one conveyor to several conveyors, or vice versa	<a href="#">B65G 47/72</a>
Fertiliser distributors, seeders	<a href="#">A01C 15/04</a>

## B65G 53/54

### Flexible pipes or tubes

#### Definition statement

*This place covers:*

Illustrative example of subject matter classified in this group:

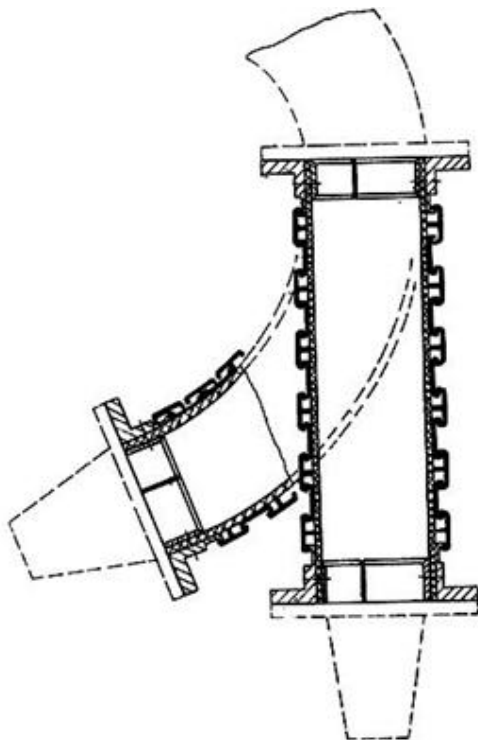

## B65G 53/56

### Switches

#### Definition statement

*This place covers:*

Illustrative example of subject matter classified in this group:

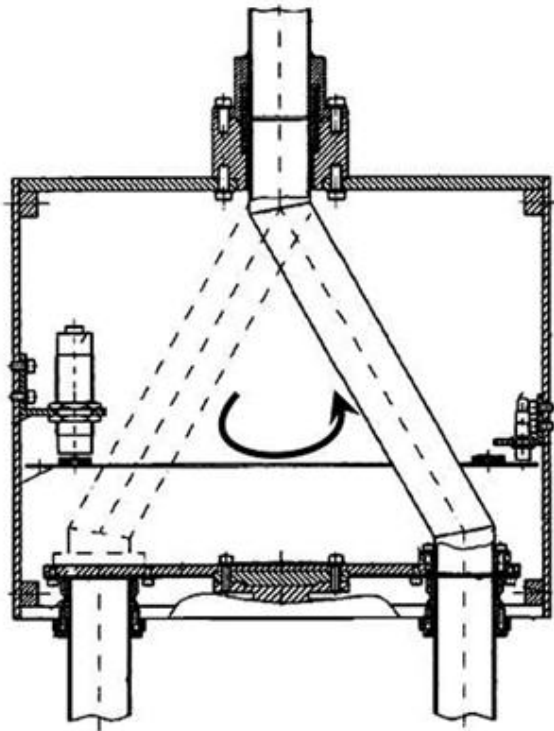
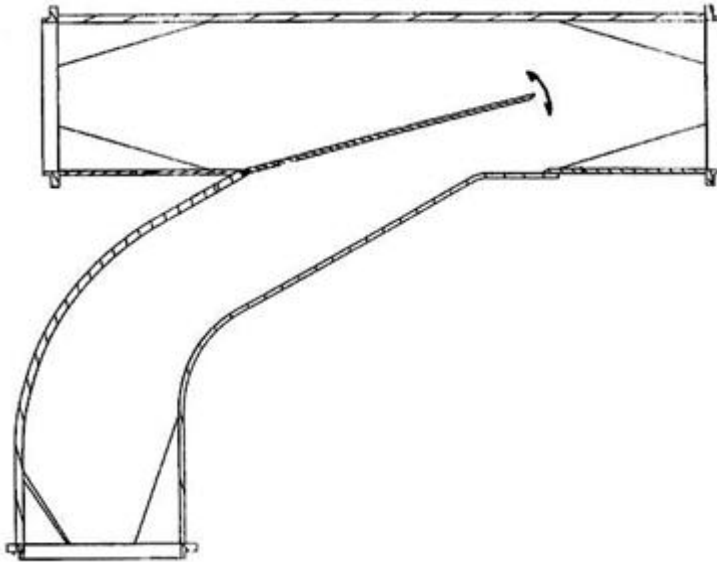

## References

### Informative references

Attention is drawn to the following places, which may be of interest for search:

Transferring materials in bulk from one conveyor to several conveyors, or vice versa	<a href="#">B65G 47/72</a>
--------------------------------------------------------------------------------------	----------------------------

## B65G 53/58

Devices for accelerating or decelerating flow of the materials; Use of pressure generators (controlling pressure of propelling gas [B65G 53/66](#))

### Definition statement

This place covers:

Illustrative example of subject matter classified in this group:

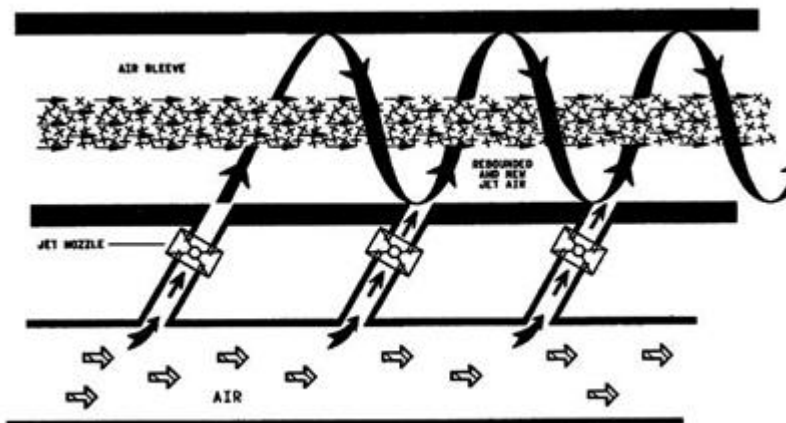

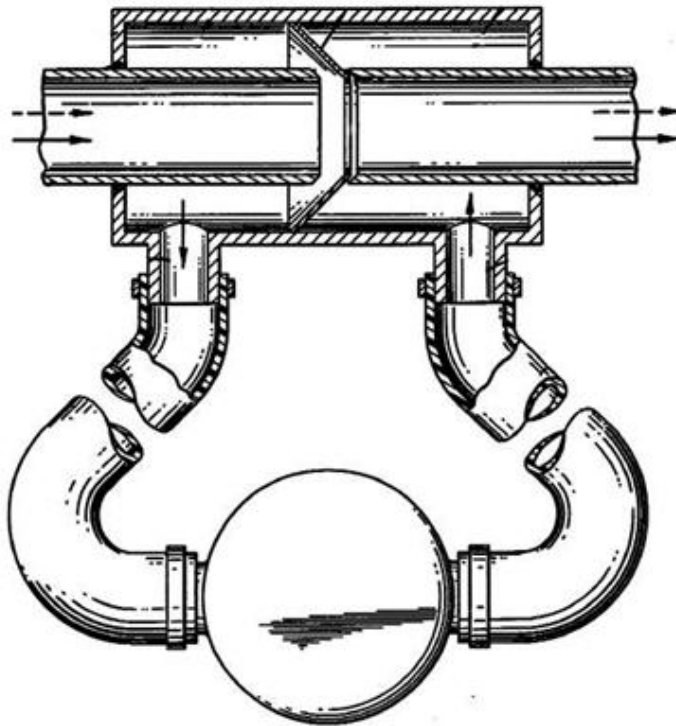

## References

### *Informative references*

*Attention is drawn to the following places, which may be of interest for search:*

Nozzles	<a href="#">B65G 53/42</a>
Means for preventing the accumulation or for removal of deposits	<a href="#">B65G 53/521</a>

**B65G 53/60****Devices for separating the materials from propellant gas****Definition statement**

*This place covers:*

Illustrative example of subject matter classified in this group:

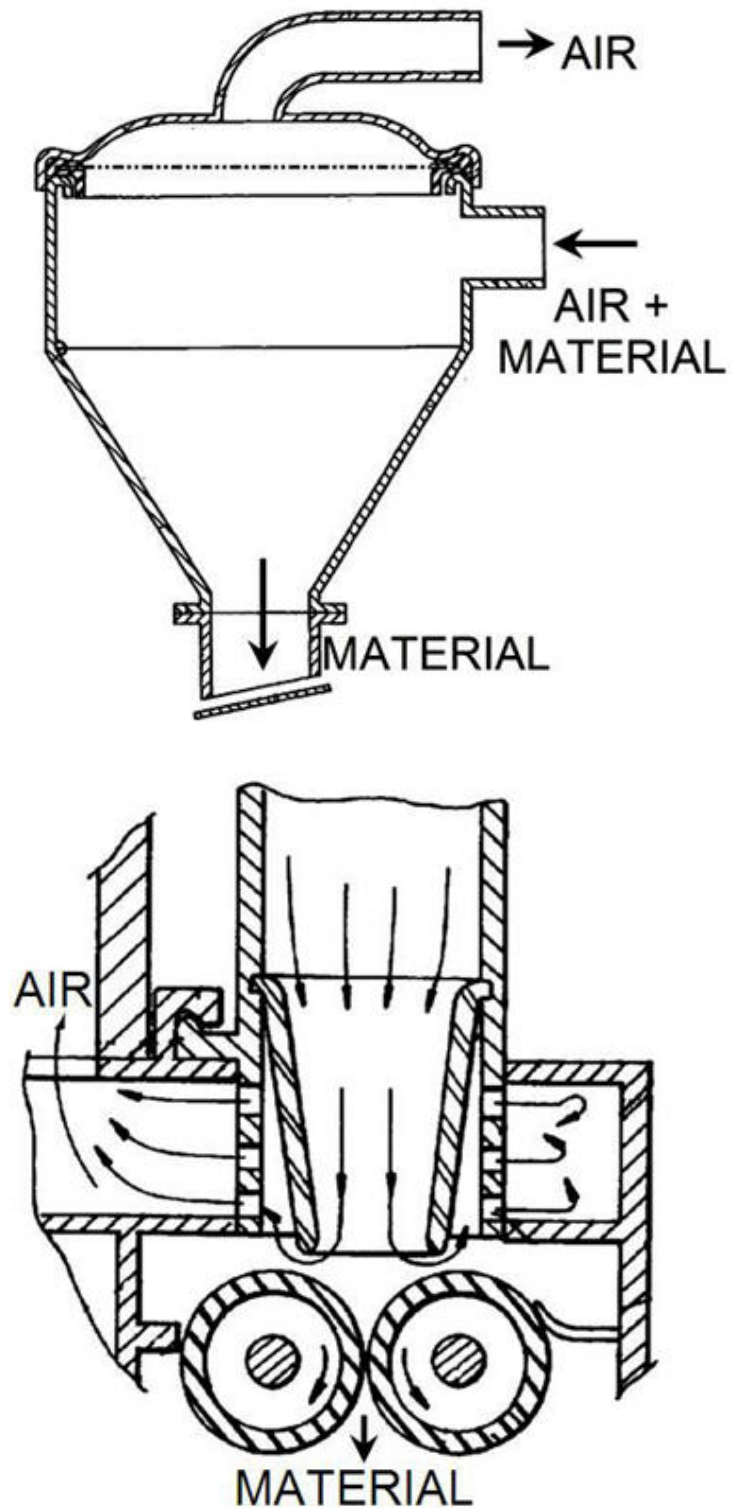

## B65G 53/62

using liquid

### Definition statement

*This place covers:*

Illustrative example of subject matter classified in this group:

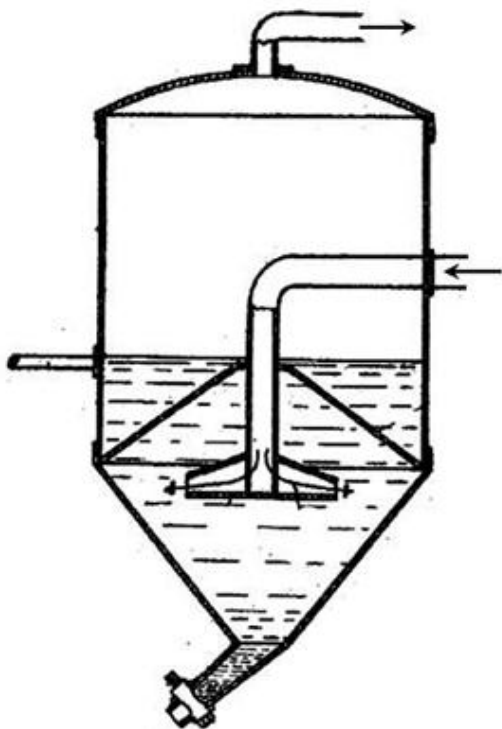

**B65G 53/64****in discrete amounts****Definition statement***This place covers:*

Illustrative example of subject matter classified in this group:

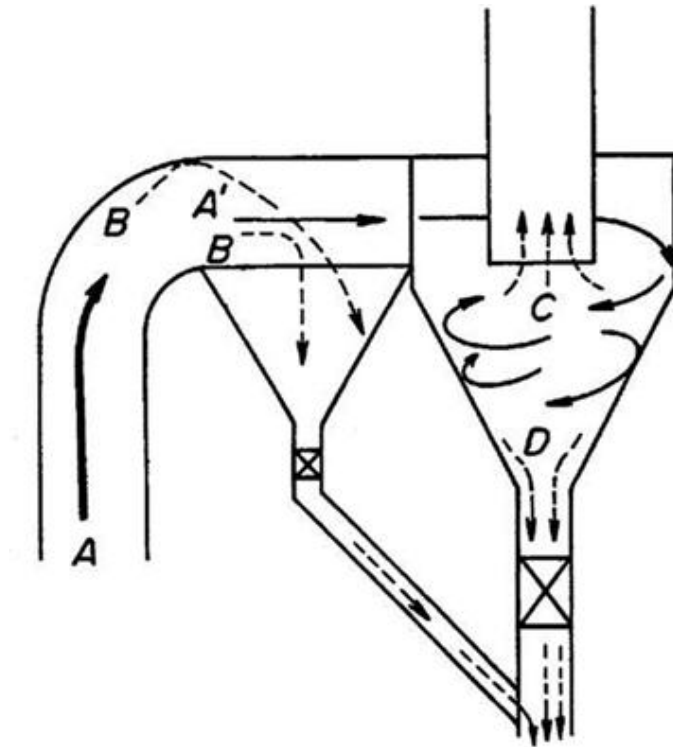
**References****Informative references***Attention is drawn to the following places, which may be of interest for search:*

Separation of materials with cyclones	<a href="#">B04C</a>
---------------------------------------	----------------------



## B65G 53/66

Use of indicator or control devices, e.g. for controlling gas pressure, for controlling proportions of material and gas, for indicating or preventing jamming of material {(controlling the flow of coal firing systems [C21B 5/003](#))}

### Definition statement

*This place covers:*

Illustrative example of subject matter classified in this group:

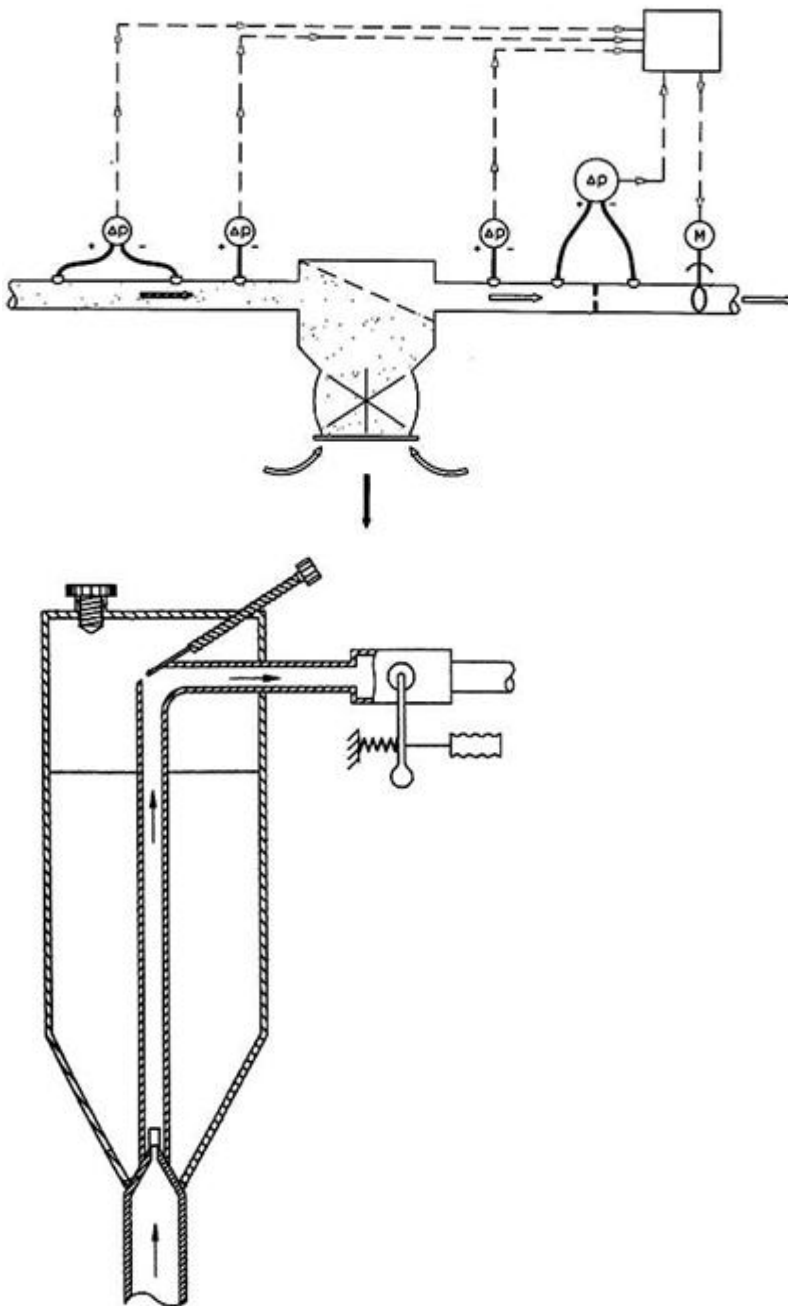

**B65G 54/00****Non-mechanical conveyors not otherwise provided for****Definition statement**

*This place covers:*

Contractless conveying, using light or sound (e.g. ultrasonic) waves

Illustrative example of subject matter classified in this group:

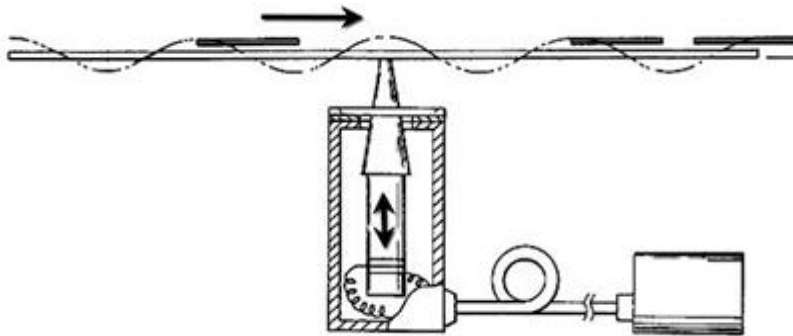
**References****Informative references**

Attention is drawn to the following places, which may be of interest for search:

For the driving means	<a href="#">B65G 27/00</a>
-----------------------	----------------------------

**B65G 54/02****electrostatic, electric, or magnetic****Definition statement**

*This place covers:*

Illustrative example of subject matter classified in this group:

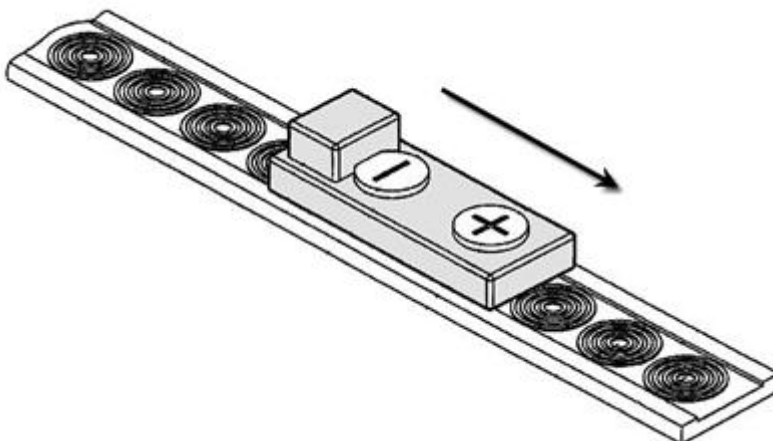

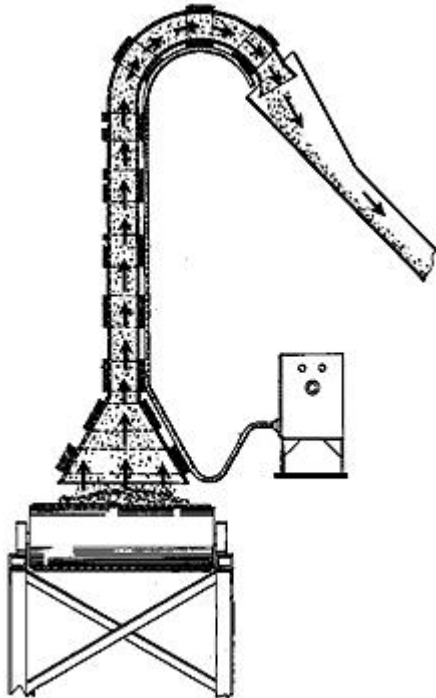

**References**

**Limiting references**

*This place does not cover:*

For driving endless conveyors	<a href="#">B65G 23/23</a>
The magnetic field is moving not the driver	<a href="#">B65G 54/025</a>

**B65G 54/025**

{the load being magnetically coupled with a piston-like driver moved within a tube}

**Definition statement**

*This place covers:*

With moving magnetical driver (e.g. permanent magnets moving)

Illustrative example of subject matter classified in this group:

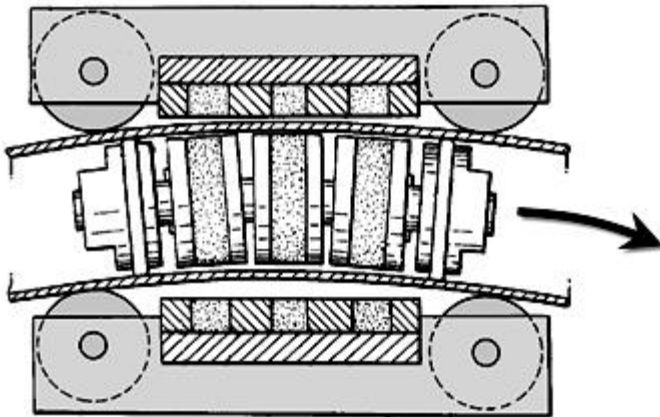

## References

### *Informative references*

*Attention is drawn to the following places, which may be of interest for search:*

Magnetic retaining means for retaining the load of the load-carrying surface	<a href="#">B65G 21/2018</a>
Devices for feeding articles or materials to conveyors using suction or magnetic forces	<a href="#">B65G 47/1485</a>

## B65G 57/00

Stacking of articles ([B65G 60/00](#) takes precedence; feeding, piling or stacking sheets [B65H](#))

### Definition statement

*This place covers:*

Illustrative example of subject matter classified in this group:

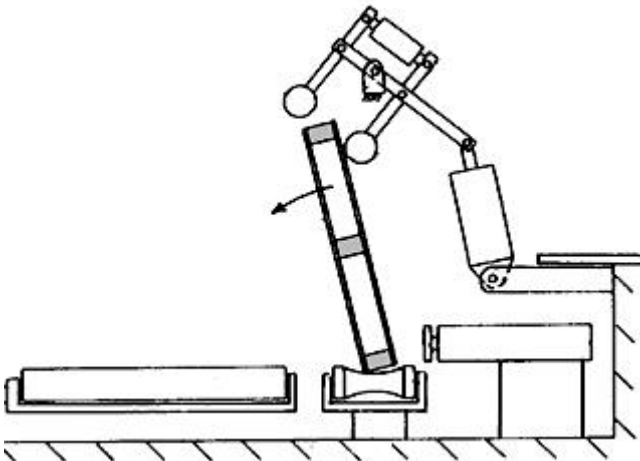
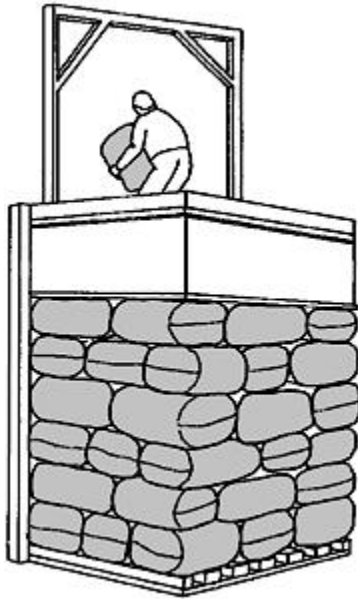

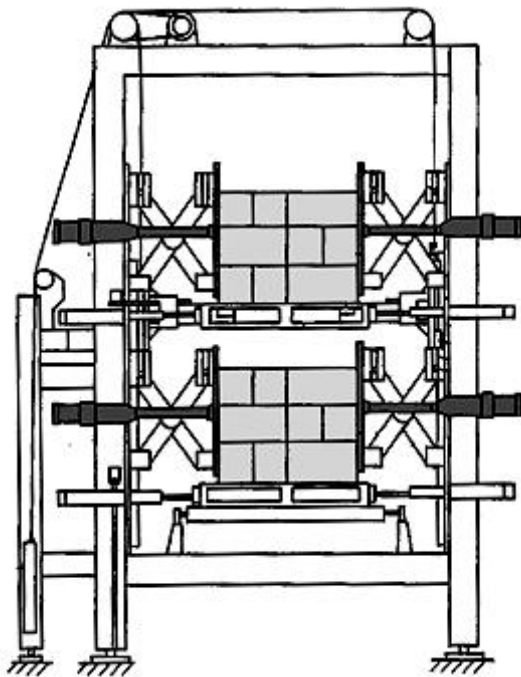

**References**

**Limiting references**

*This place does not cover:*

Simultaneously or alternatively stacking and de-stacking of articles	<a href="#">B65G 60/00</a>
Feeding, piling or stacking sheets	<a href="#">B65H</a>

**Informative references**

*Attention is drawn to the following places, which may be of interest for search:*

Handling of (empty) pallets, stacking frames, stacking manually, aligning the stack, shape or form of stack	<a href="#">B65G 1/00</a>
Glass sheets	<a href="#">B65G 49/068</a>
Stacking devices	<a href="#">B65G 2814/0304</a>
Adding to the top	<a href="#">B65G 2814/0305</a>
Loading platform being lowered during stacking	<a href="#">B65G 2814/0307</a>
Stacking of jumbo rolls	<a href="#">B41F</a>
Wrapping a stack	<a href="#">B65B 11/00</a>
Stacking one article, or group of articles in groups	<a href="#">B65B 35/50</a>
Stackable containers	<a href="#">B65D</a>
Stacking of coins	<a href="#">G07D 9/06</a>

**B65G 57/005**

{by using insertions or spacers between the stacked layers}

**Definition statement**

*This place covers:*

Illustrative example of subject matter classified in this group:

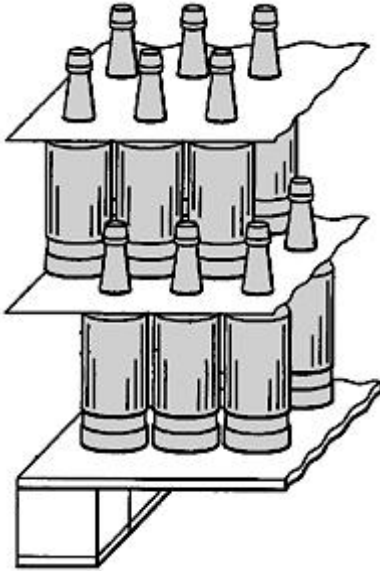
**References****Informative references**

*Attention is drawn to the following places, which may be of interest for search:*

Inserting partitions between package contents	<a href="#">B65B 61/207</a>
Trays provided with projections or recesses in order to assemble multiple articles	<a href="#">B65D 71/70</a>
Use and construction of spacers	<a href="#">F26B 25/185</a>

**B65G 57/03**

from above

**Definition statement**

*This place covers:*

Illustrative example of subject matter classified in this group:

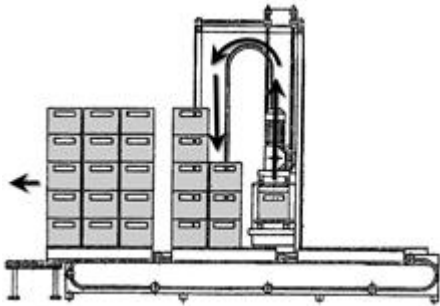
**B65G 57/035**

{with a stepwise downward movement of the stack}

**Definition statement**

*This place covers:*

Illustrative example of subject matter classified in this group:

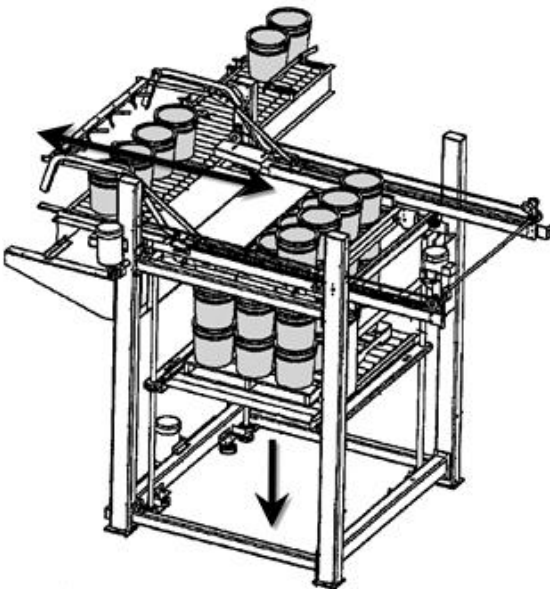
**References****Informative references**

Attention is drawn to the following places, which may be of interest for search:

The articles being stacked by direct action of the feeding conveyor	<a href="#">B65G 57/11</a>
---------------------------------------------------------------------	----------------------------



**B65G 57/04****by suction or magnetic devices****Definition statement***This place covers:*

Illustrative example of subject matter classified in this group:

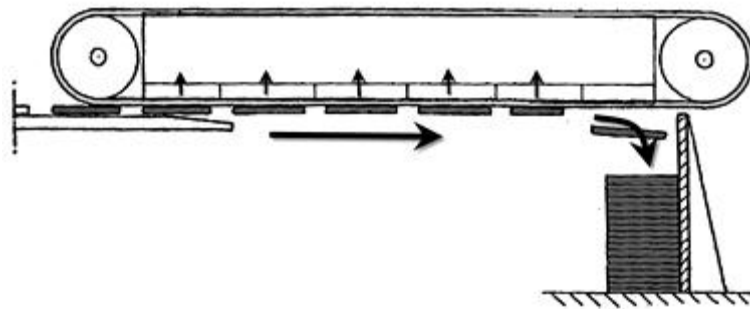
**References****Informative references***Attention is drawn to the following places, which may be of interest for search:*

Magnetic load-carriers	<a href="#">B65G 21/2018</a>
Suction	<a href="#">B65G 21/2036</a>
For steel sheets	<a href="#">B21D 43/22</a>

**B65G 57/06****Gates for releasing articles****Definition statement***This place covers:*

Illustrative example of subject matter classified in this group:

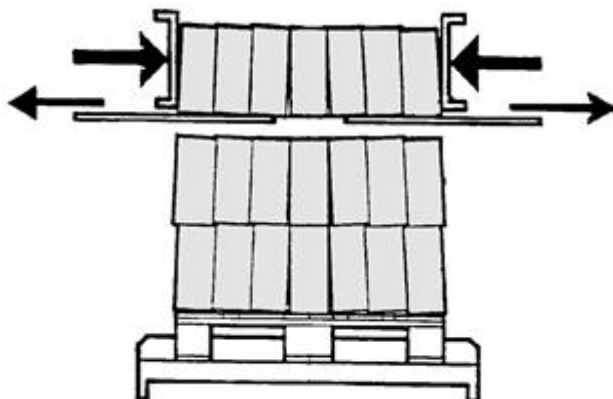

**B65G 57/08**

articles being tilted or inverted prior to depositing

**Definition statement**

*This place covers:*

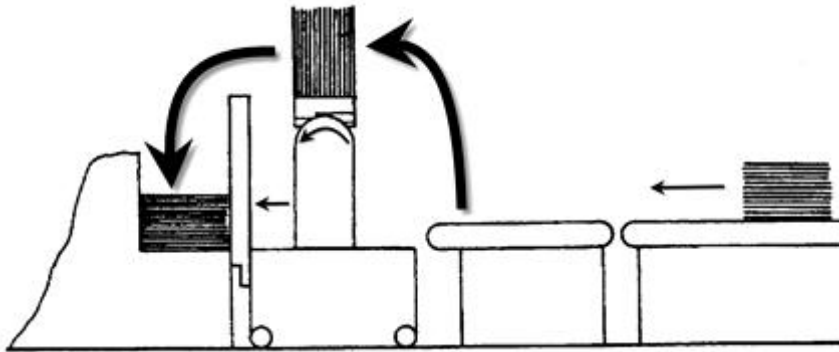
**B65G 57/081**

alternate articles being inverted

**Definition statement**

*This place covers:*

Illustrative example of subject matter classified in this group:

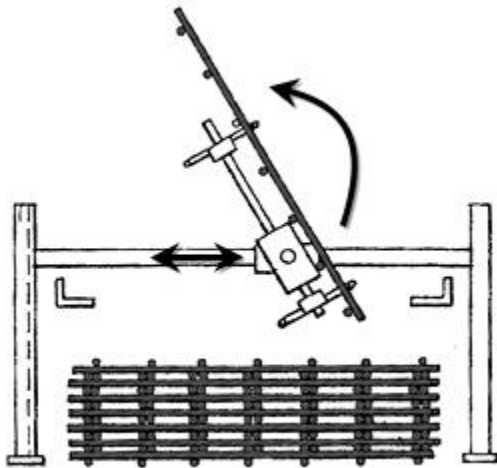
**B65G 57/10**

by devices, e.g. reciprocating, acting directly on articles for horizontal transport to the top of stack

**Definition statement**

*This place covers:*

Additionally to the feeding conveyor, a transfer device is provided to bring the article(s) on top of the stack

Illustrative example of subject matter classified in this group:

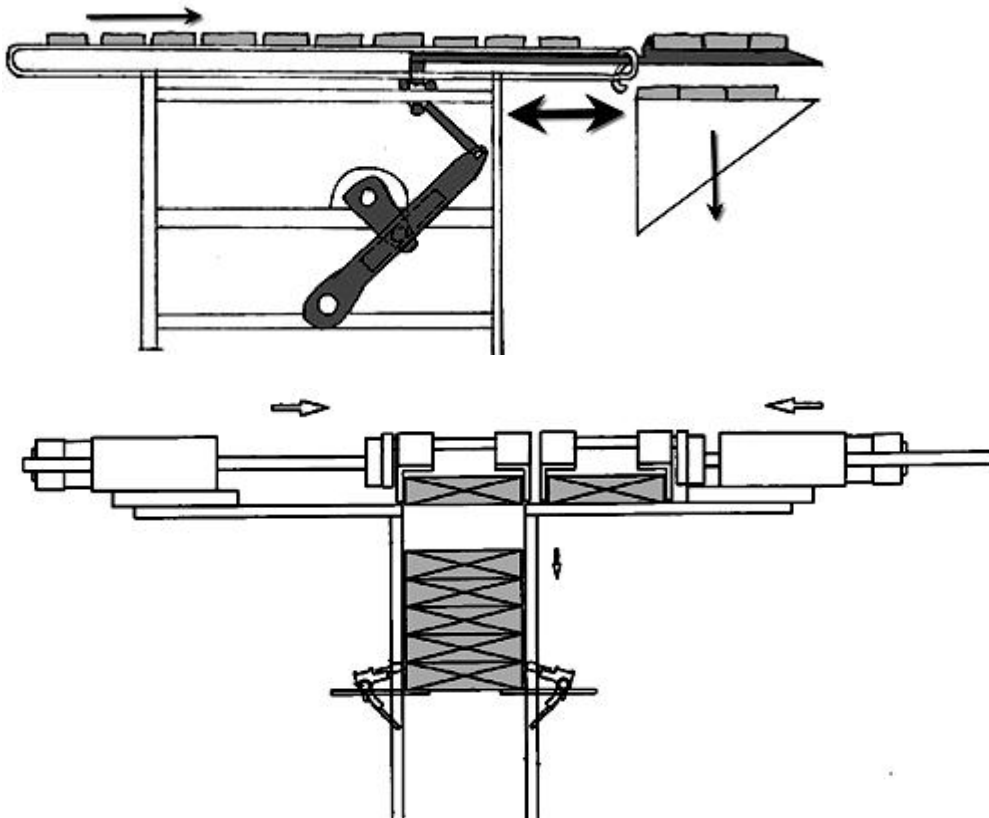

**B65G 57/11**

the articles being stacked by direct action of the feeding conveyor

**Definition statement**

*This place covers:*

Illustrative example of subject matter classified in this group:

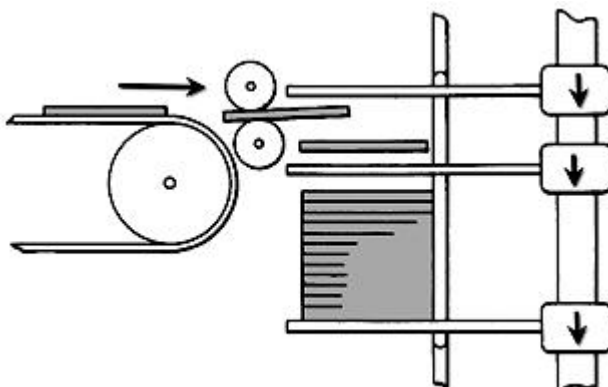

**B65G 57/112**

**the conveyor being adjustable in height**

**Definition statement**

*This place covers:*

Illustrative example of subject matter classified in this group:

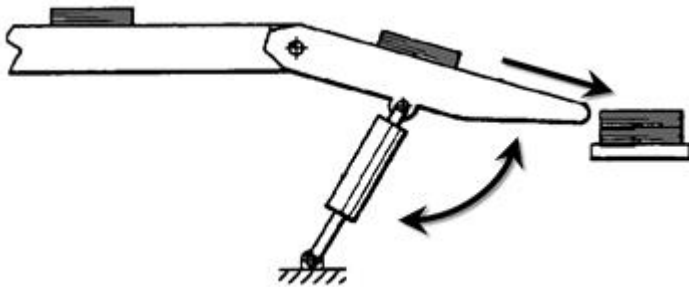
**B65G 57/14**

**the articles being transferred from carriers moving in an endless path adjacent to the stacks**

**Definition statement**

*This place covers:*

Illustrative example of subject matter classified in this group:

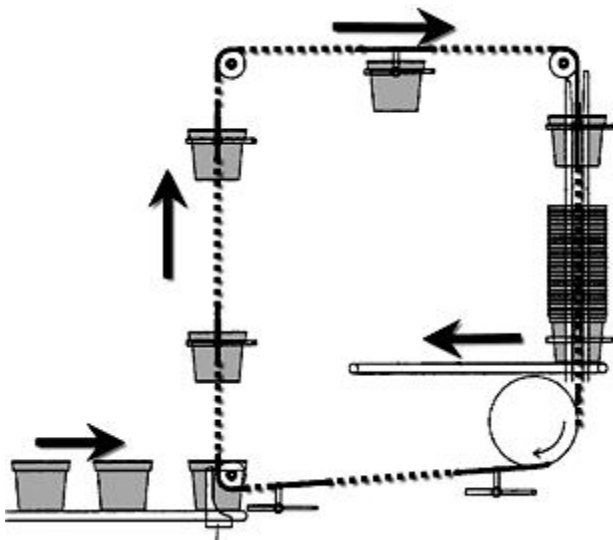
**References****Informative references**

*Attention is drawn to the following places, which may be of interest for search:*

Conveyor constructions	<a href="#">B65G 15/00</a> - <a href="#">B65G 35/00</a>
Combinations of conveyors	<a href="#">B65G 37/00</a>
Grouping articles in rows	<a href="#">B65G 47/082</a>

**B65G 57/165**

{nested}

**Definition statement***This place covers:*

Illustrative example of subject matter classified in this group:

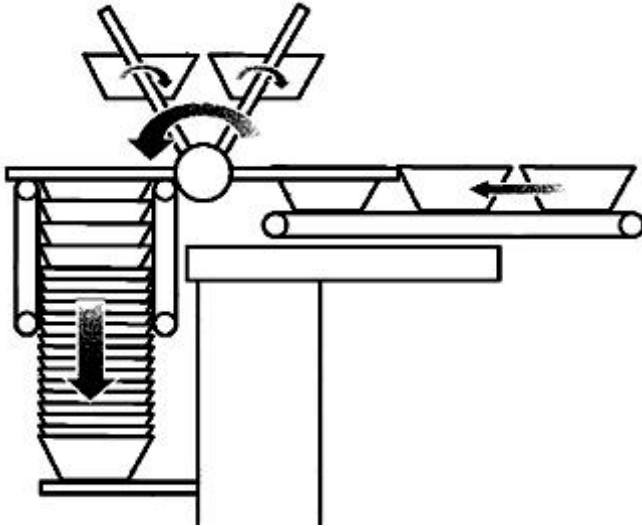
**B65G 57/18**

elongated, e.g. sticks, rods, bars

**Definition statement***This place covers:*

Illustrative example of subject matter classified in this group:

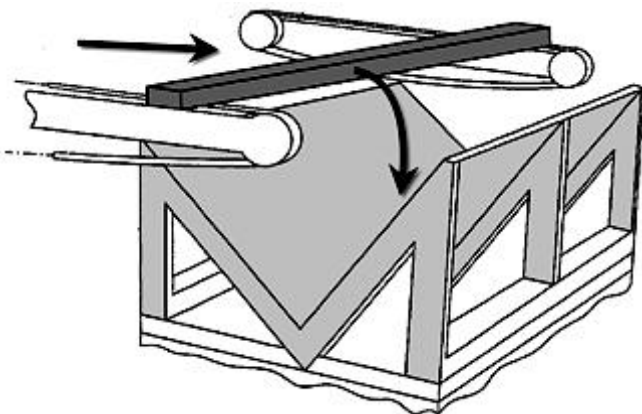
**References****Limiting references***This place does not cover:*

Cylindrical articles	<a href="#">B65G 57/186</a>
----------------------	-----------------------------

**B65G 57/183****{Angle irons}****Definition statement***This place covers:*

Illustrative example of subject matter classified in this group:

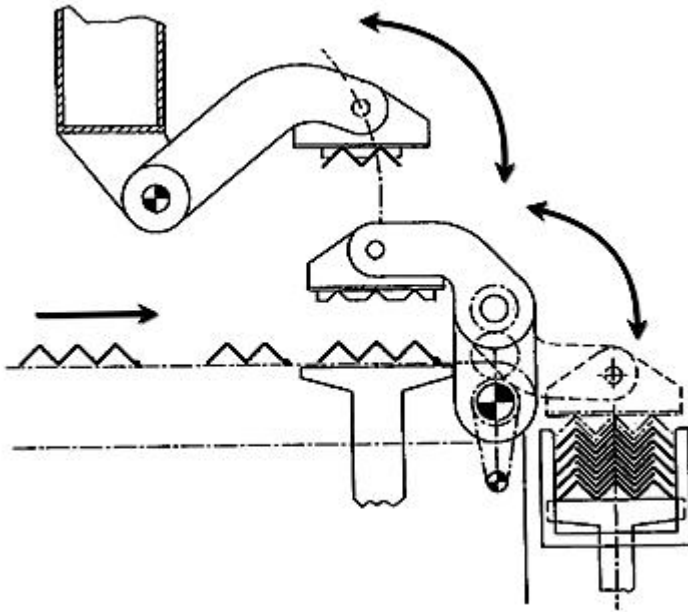
**B65G 57/186****{Cylindrical articles, e.g. tubes, rods, etc.}****Definition statement***This place covers:*

Illustrative example of subject matter classified in this group:

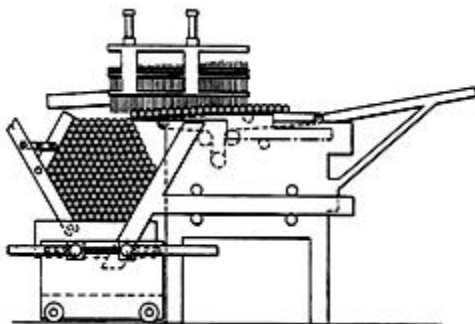
**References****Informative references***Attention is drawn to the following places, which may be of interest for search:*

Elongated, e.g. sticks, rods, bars

[B65G 57/18](#)

**B65G 57/20**

three-dimensional, e.g. cubiform, cylindrical

**Definition statement**

*This place covers:*

Illustrative example of subject matter classified in this group:

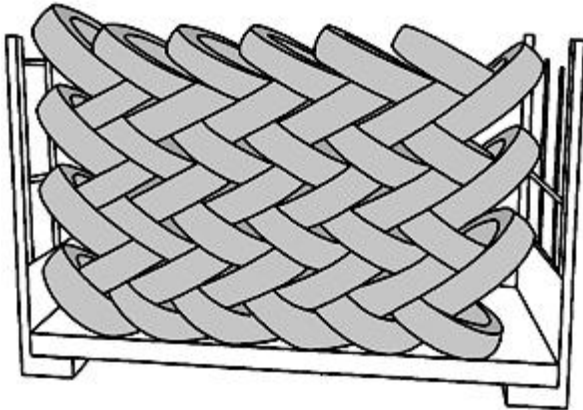
**References****Informative references**

Attention is drawn to the following places, which may be of interest for search:

Reducing volume of filled material	<a href="#">B65B 1/24</a>
------------------------------------	---------------------------

**B65G 57/22**

in layers each of predetermined arrangement

**Definition statement**

*This place covers:*

Illustrative example of subject matter classified in this group:

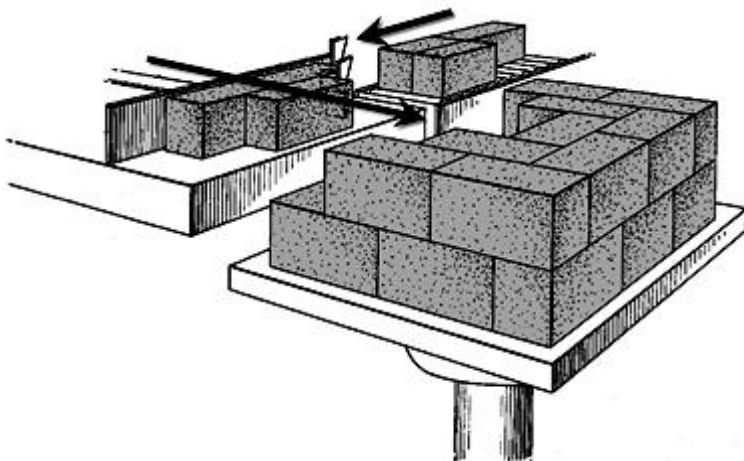

## B65G 57/24

the layers being transferred as a whole, e.g. on pallets

### Definition statement

*This place covers:*

Illustrative example of subject matter classified in this group:

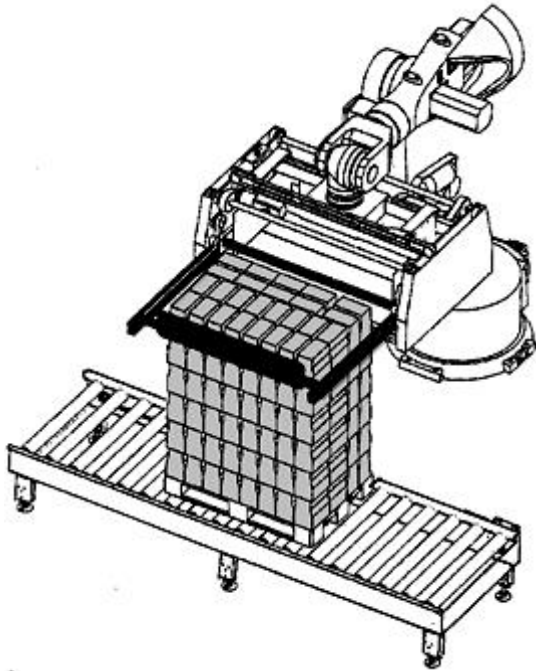

### References

#### *Informative references*

*Attention is drawn to the following places, which may be of interest for search:*

Use of pick-up transfer devices or of manipulators for stacking or de-stacking articles not otherwise provided for	<a href="#">B65G 61/00</a>
--------------------------------------------------------------------------------------------------------------------	----------------------------



## B65G 57/245

{with a stepwise downward movement of the stack}

### Definition statement

*This place covers:*

Illustrative example of subject matter classified in this group:

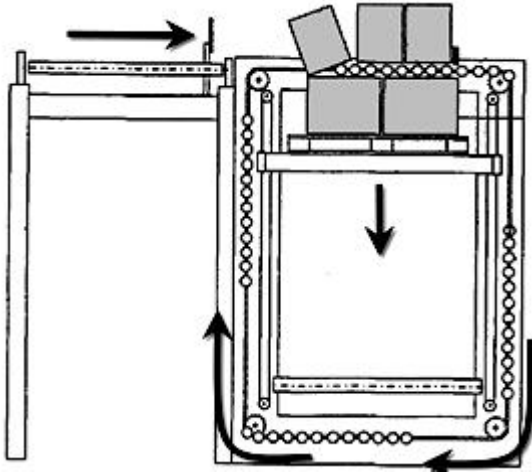

## B65G 57/26

the arrangement providing for spaces between the articles

### Definition statement

*This place covers:*

Illustrative example of subject matter classified in this group:

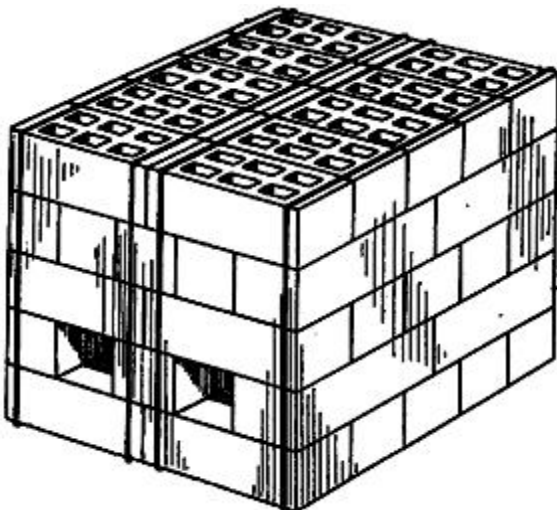

**B65G 57/28**

by assembling the articles and tilting the assembled articles to a stacked position

**Definition statement**

*This place covers:*

Illustrative example of subject matter classified in this group:

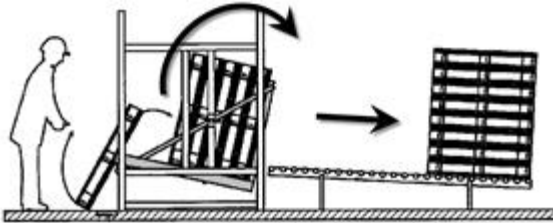
**B65G 57/30**

by adding to the bottom of the stack

**Definition statement**

*This place covers:*

Illustrative example of subject matter classified in this group:

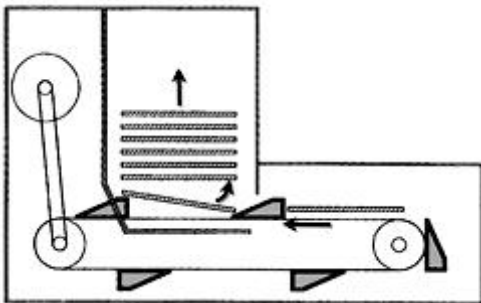
**B65G 57/301**

{by means of reciprocatory or oscillatory lifting and holding or gripping devices}

**Definition statement**

*This place covers:*

Illustrative example of subject matter classified in this group:

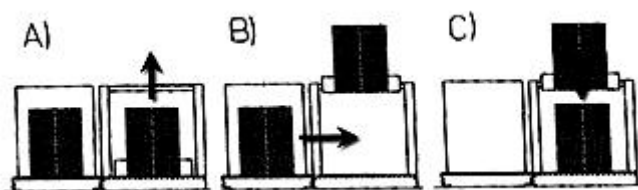

## B65G 57/302

{added articles being lifted to substantially stationary grippers or holders}

### Definition statement

*This place covers:*

Illustrative example of subject matter classified in this group:

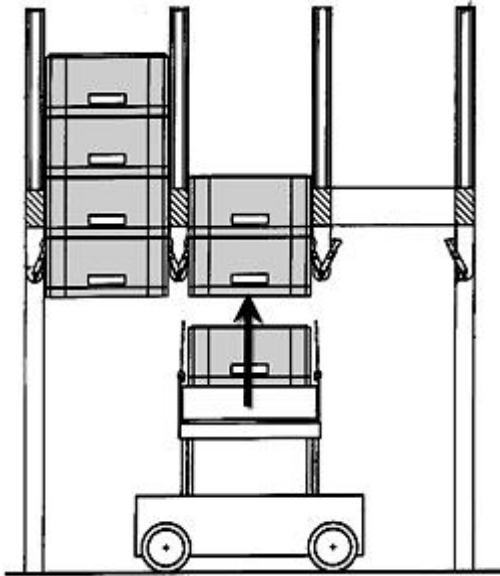

## B65G 57/303

{the stack being lowered by mobile grippers or holders onto added articles}

### Definition statement

*This place covers:*

Illustrative example of subject matter classified in this group:



## B65G 57/306

{the rotary devices being wheels}

### Definition statement

*This place covers:*

Illustrative example of subject matter classified in this group:

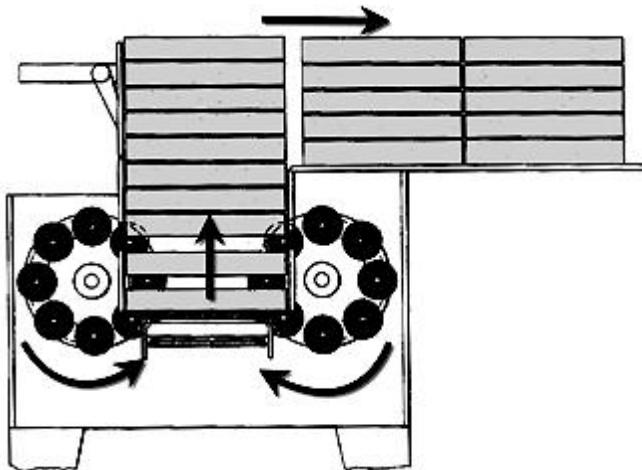

## B65G 57/307

{the rotary devices being screws}

### Definition statement

*This place covers:*

Illustrative example of subject matter classified in this group:

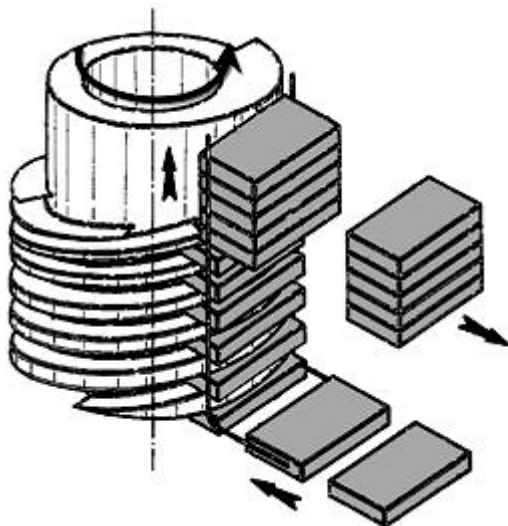

**B65G 57/308****{by means of endless elements}****Definition statement***This place covers:*

Illustrative example of subject matter classified in this group:

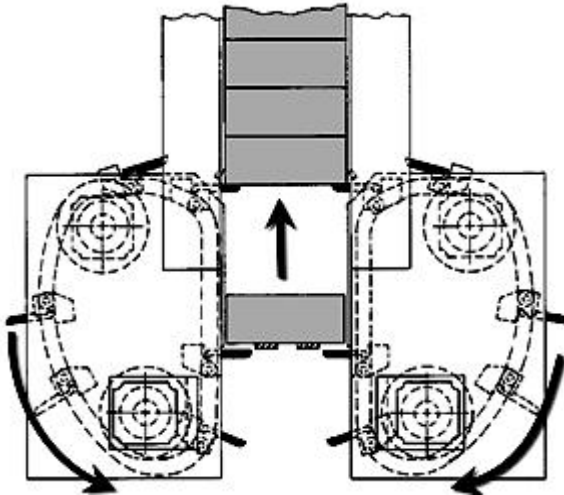
**B65G 57/32****characterised by stacking during transit****Definition statement***This place covers:*

Illustrative example of subject matter classified in this group:

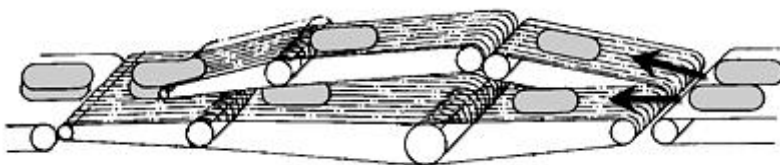
**B65G 59/00****De-stacking of articles ([B65G 60/00](#) takes precedence)****References****Limiting references***This place does not cover:*

Simultaneously or alternatively stacking and de-stacking of articles	<a href="#">B65G 60/00</a>
----------------------------------------------------------------------	----------------------------

**Informative references**

Attention is drawn to the following places, which may be of interest for search:

Glass sheets	<a href="#">B65G 49/068</a>
When the layers are transferred as a whole	<a href="#">B65G 60/00</a>
Destacking devices	<a href="#">B65G 2814/0308</a>
Removing from the top	<a href="#">B65G 2814/031</a>
Other sheets	<a href="#">B65H</a>

**B65G 59/005**

{by using insertions or spacers between the stacked layers}

**Definition statement**

*This place covers:*

Illustrative example of subject matter classified in this group:

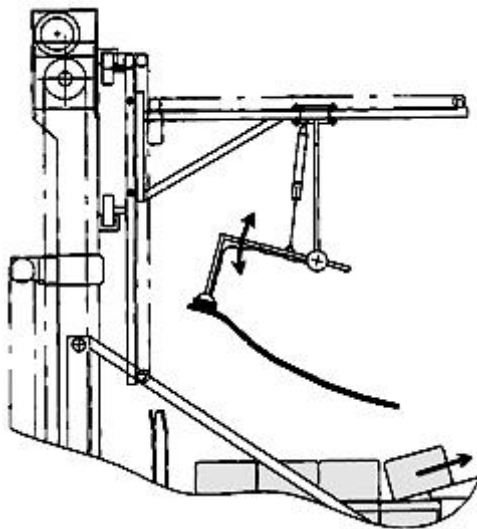
**References****Informative references**

Attention is drawn to the following places, which may be of interest for search:

When the layers are transferred as a whole	3F030/BA08
Collecting spacers (UCLA)	414/929

**B65G 59/02****De-stacking from the top of the stack****Definition statement**

*This place covers:*

Illustrative example of subject matter classified in this group:

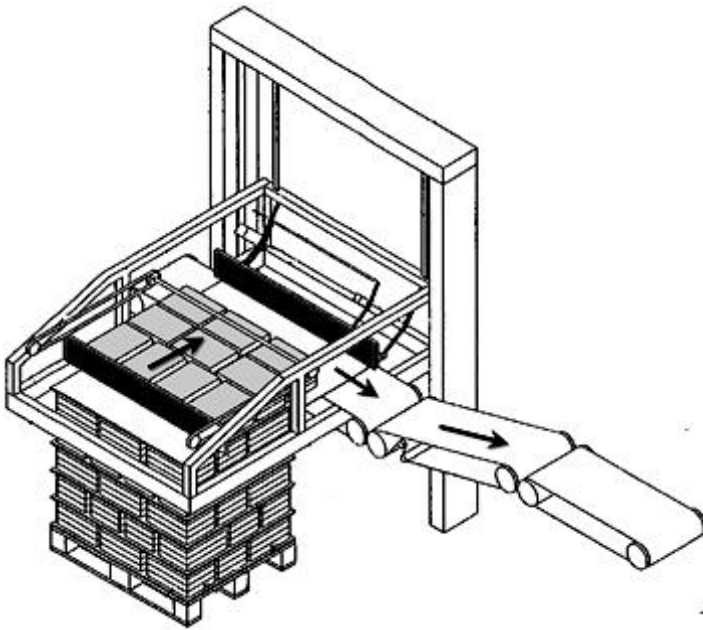
**References****Limiting references**

*This place does not cover:*

De-stacked nested articles	<a href="#">B65G 59/10</a>
----------------------------	----------------------------

**B65G 59/023**

{by means insertable between the stacked articles or layers}

**Definition statement**

*This place covers:*

Illustrative example of subject matter classified in this group:

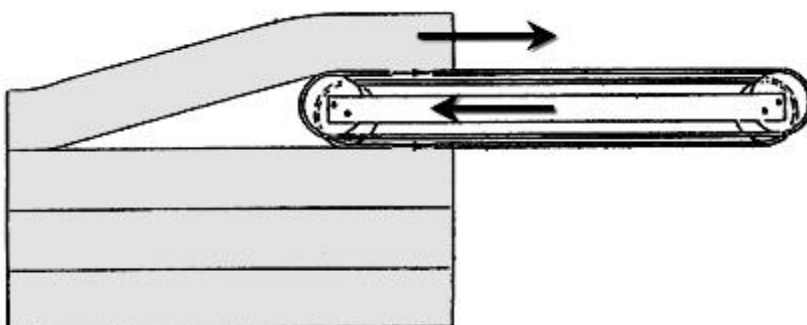

**B65G 59/026**

{with a stepwise upward movement of the stack}

**Definition statement**

*This place covers:*

Illustrative example of subject matter classified in this group:

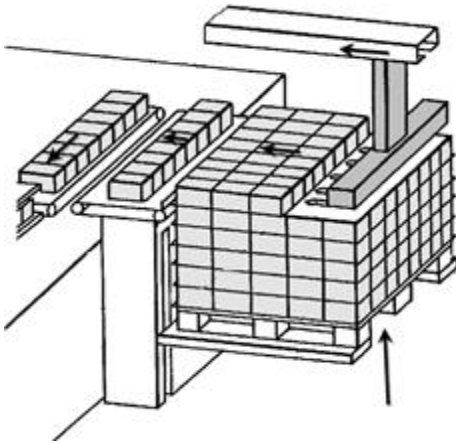
**B65G 59/04**

by suction or magnetic devices

**Definition statement**

*This place covers:*

Illustrative example of subject matter classified in this group:

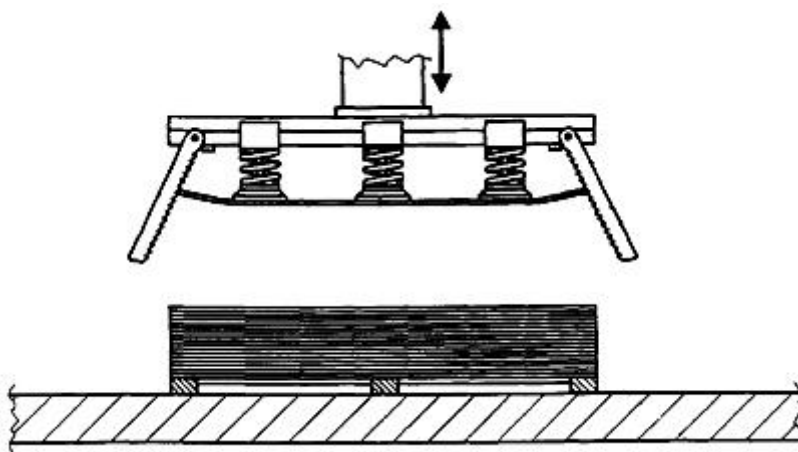
**References****Informative references**

Attention is drawn to the following places, which may be of interest for search:

Magnetic means for retaining the load on the load-carrying surface	<a href="#">B65G 21/2018</a>
Suction means for retaining the load on the load-carrying surface	<a href="#">B65G 21/2036</a>
Steel sheets	<a href="#">B21D 43/24</a>



**B65G 59/045**

{with a stepwise upward movement of the stack}

**Definition statement**

*This place covers:*

Illustrative example of subject matter classified in this group:

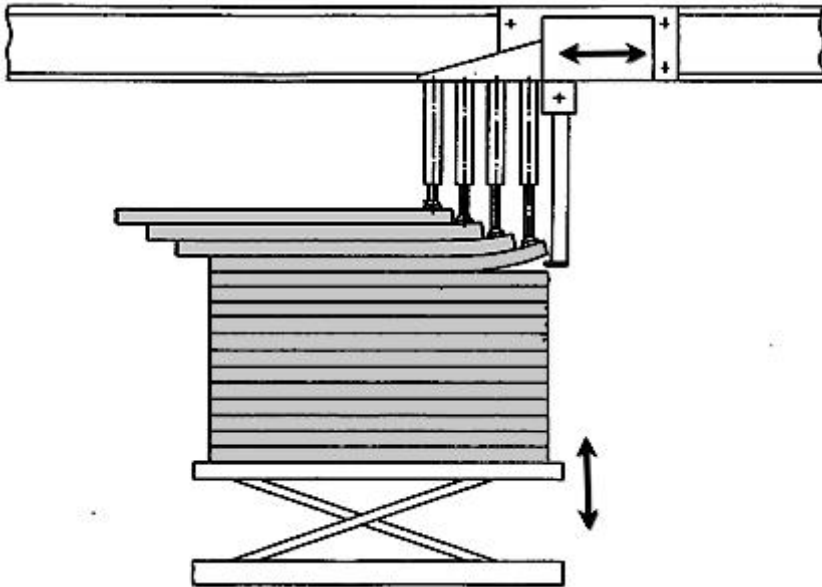
**B65G 59/062**

{by means of reciprocating or oscillating escapement-like mechanisms}

**Definition statement**

*This place covers:*

Illustrative example of subject matter classified in this group:

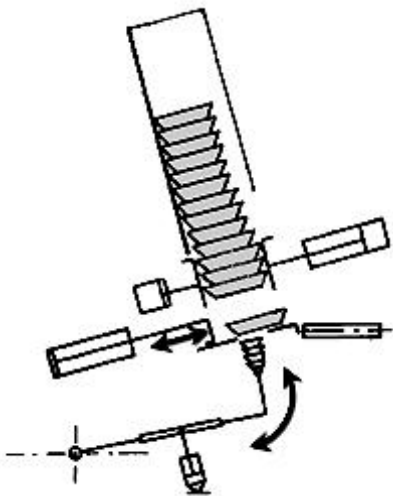

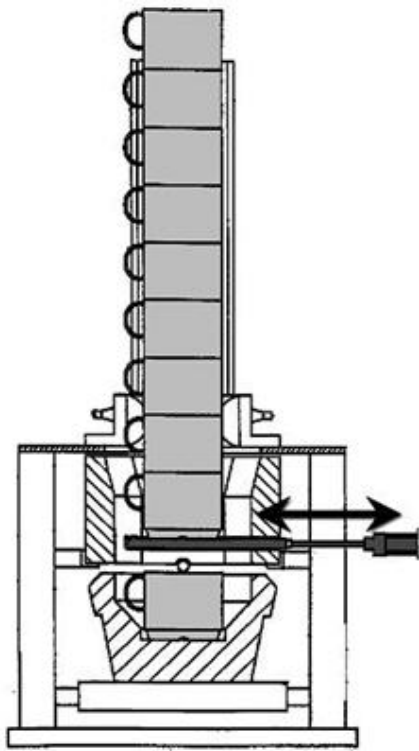

## References

### Informative references

Attention is drawn to the following places, which may be of interest for search:

Nested articles	<a href="#">B65G 59/103</a>
-----------------	-----------------------------

## B65G 59/063

{comprising lifting means}

### Definition statement

This place covers:

Illustrative example of subject matter classified in this group:

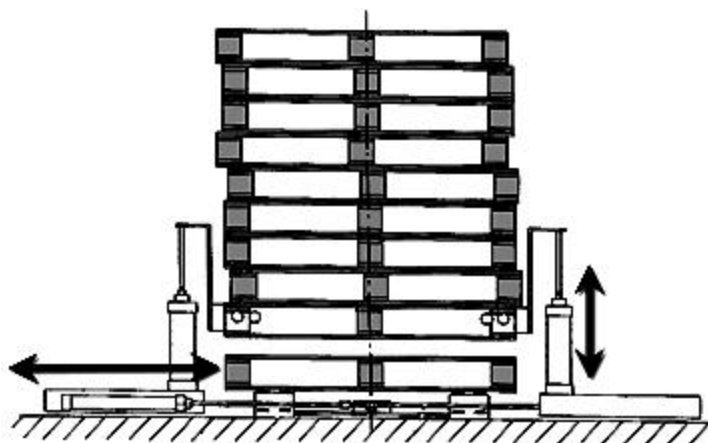

## References

### Informative references

Attention is drawn to the following places, which may be of interest for search:

Articles being separated substantially perpendicularly to the axis of the stack	<a href="#">B65G 59/067</a>
---------------------------------------------------------------------------------	-----------------------------

## B65G 59/065

{by angularly displacing the stack relatively to the lower most article or vice versa}

### Definition statement

This place covers:

Illustrative example of subject matter classified in this group:

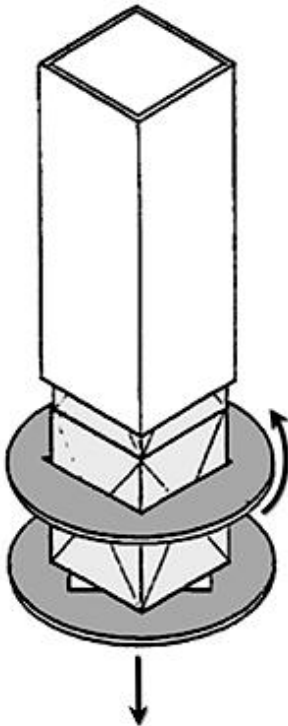

**B65G 59/066**

{by means of rotary devices or endless elements}

**Definition statement**

*This place covers:*

Illustrative example of subject matter classified in this group:

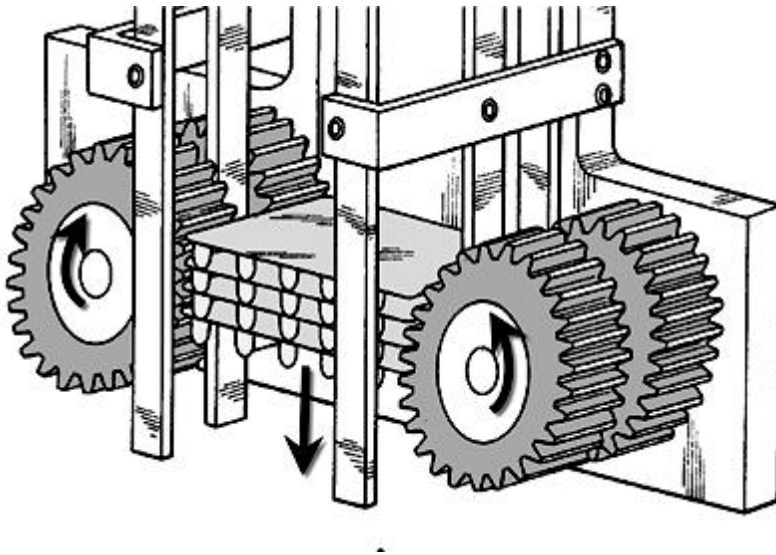
**B65G 59/067**

{articles being separated substantially perpendicularly to the axis of the stack}

**Definition statement**

*This place covers:*

Only when articles are laying on each other without prior separation by lifting means

Illustrative example of subject matter classified in this group:

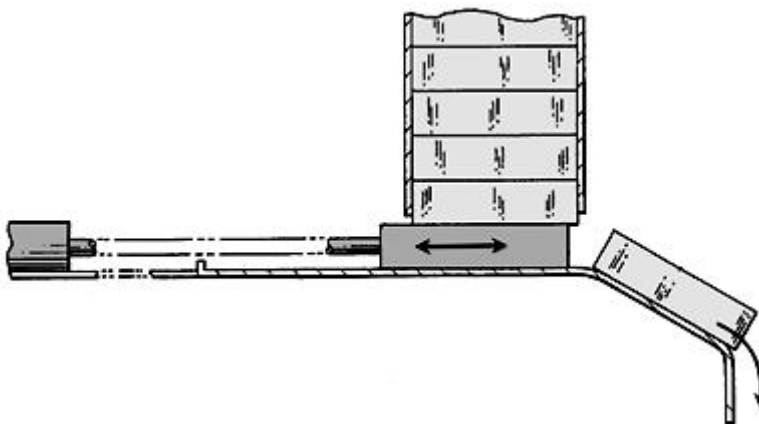

## References

### Limiting references

*This place does not cover:*

With prior separation by lifting means	<a href="#">B65G 59/063</a>
----------------------------------------	-----------------------------

## B65G 59/068

{by means of endless elements}

### Definition statement

*This place covers:*

Only when articles are laying on each other without prior separation by lifting means

Illustrative example of subject matter classified in this group:

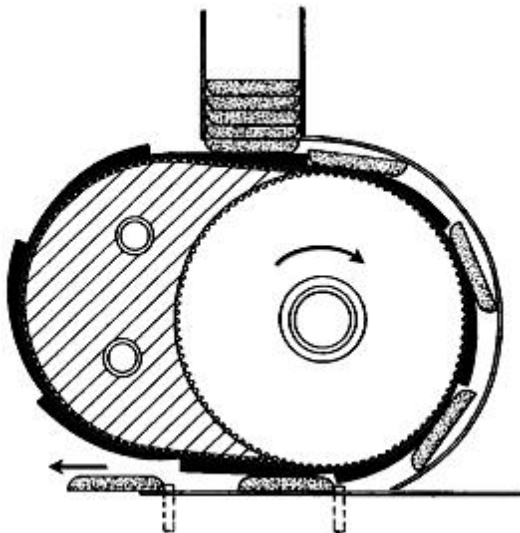

## References

### Limiting references

*This place does not cover:*

With prior separation by lifting means	<a href="#">B65G 59/066</a>
----------------------------------------	-----------------------------

## B65G 59/08

### De-stacking after preliminary tilting of the stack

#### Definition statement

*This place covers:*

Illustrative example of subject matter classified in this group:

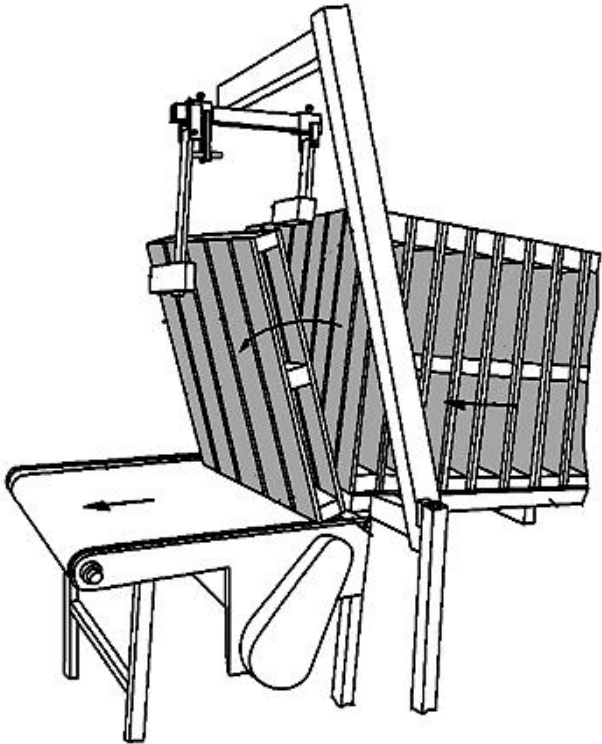

**B65G 59/10****De-stacking nested articles****Definition statement**

*This place covers:*

Illustrative example of subject matter classified in this group:

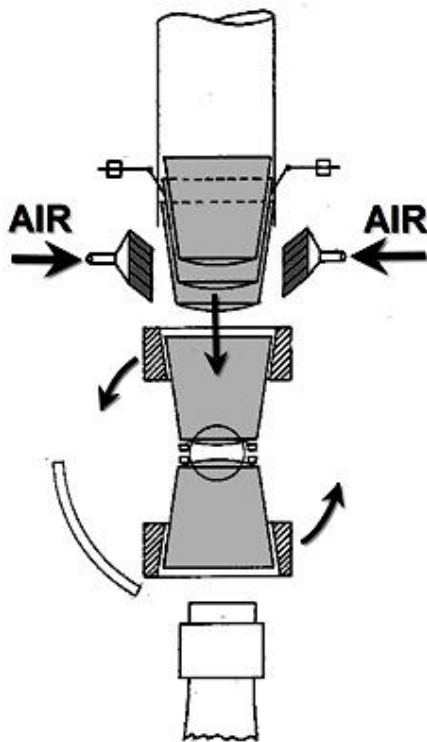
**References****Informative references**

Attention is drawn to the following places, which may be of interest for search:

Dispensers	<a href="#">A47F 1/106</a>
------------	----------------------------

**B65G 59/101**

{by means of oscillating escapement-like mechanisms}

**Definition statement**

*This place covers:*

Means pivoting about an axis

Illustrative example of subject matter classified in this group:

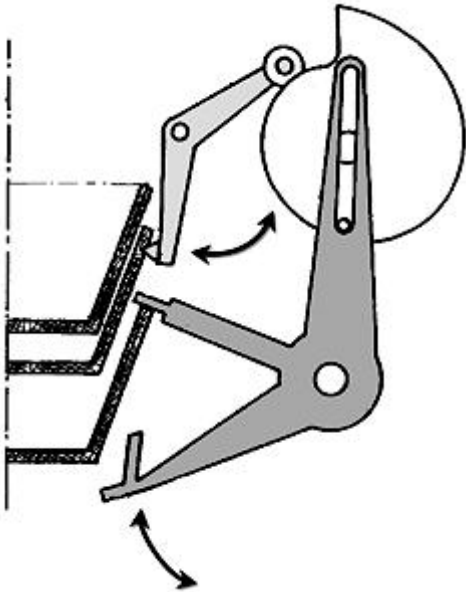

**B65G 59/102**

{the axis of oscillation being substantially parallel to the axis of the stack}

**Definition statement**

*This place covers:*

Illustrative example of subject matter classified in this group:

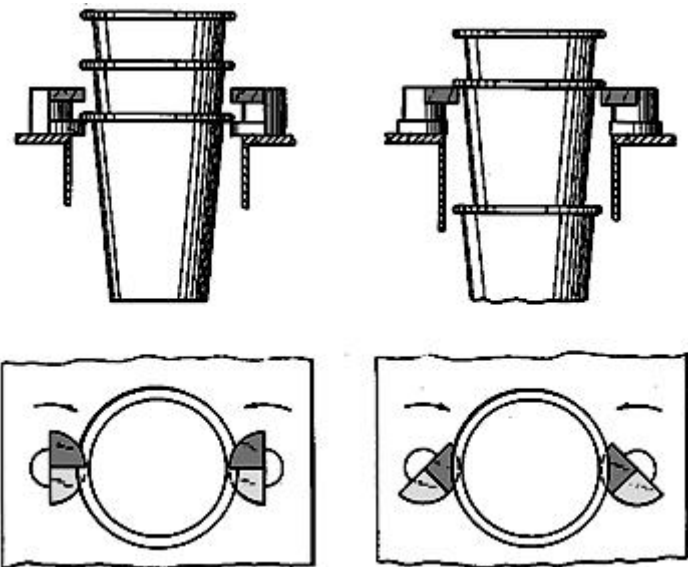



**B65G 59/103****{comprising lifting or gripping means}****Definition statement***This place covers:*

Illustrative example of subject matter classified in this group:

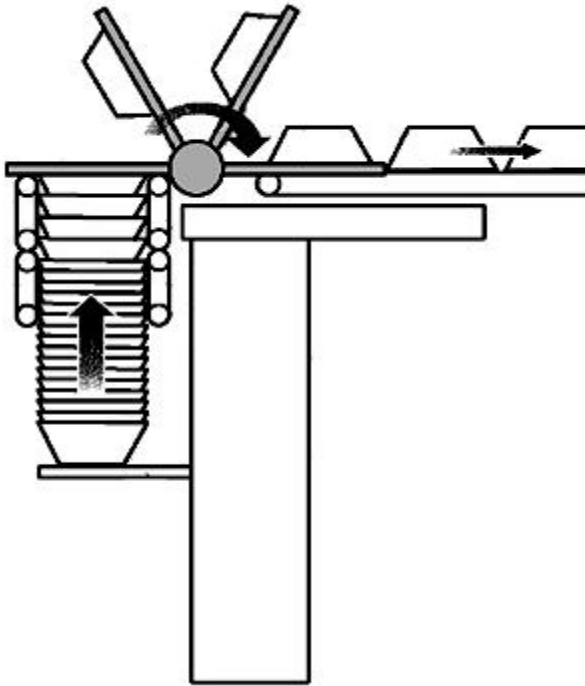
**References*****Informative references****Attention is drawn to the following places, which may be of interest for search:*

De-stacking from the bottom of the stack by means of reciprocating or oscillating escapement-like mechanisms	<a href="#">B65G 59/062</a>
--------------------------------------------------------------------------------------------------------------	-----------------------------

**B65G 59/105****{by means of reciprocating escapement-like mechanisms}****Definition statement***This place covers:*

Means with a linear path

Illustrative example of subject matter classified in this group:

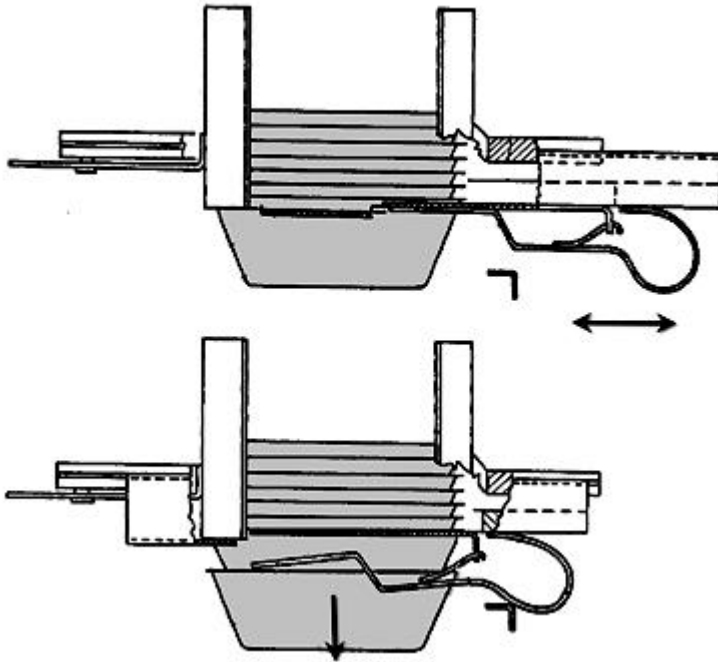

**B65G 59/106**

{comprising lifting or gripping means}

**Definition statement**

*This place covers:*

Illustrative example of subject matter classified in this group:

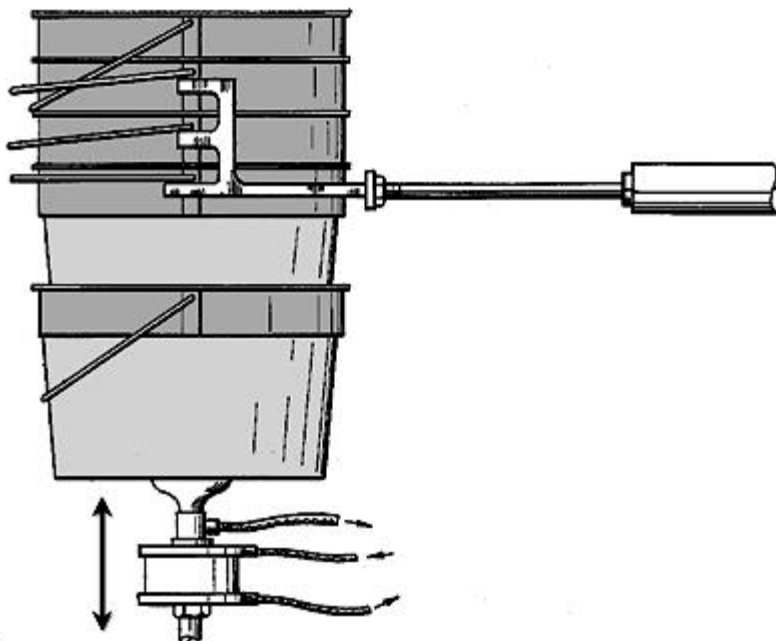

## B65G 59/107

{by means of rotary devices or endless elements}

### Definition statement

*This place covers:*

Illustrative example of subject matter classified in this group:

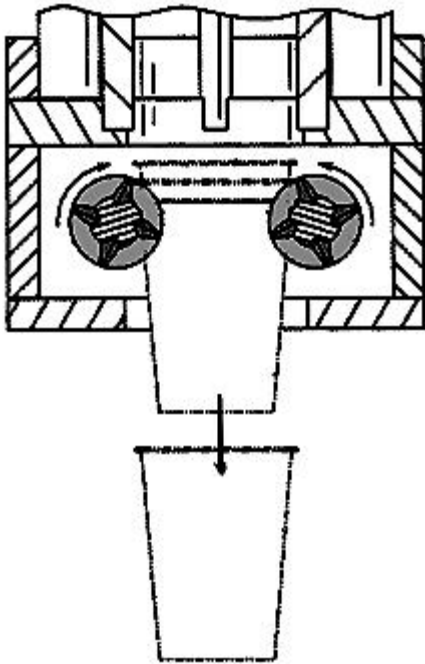

**B65G 59/108**

{the axis of rotation being substantially parallel to the axis of the stack}

**Definition statement**

*This place covers:*

Illustrative example of subject matter classified in this group:

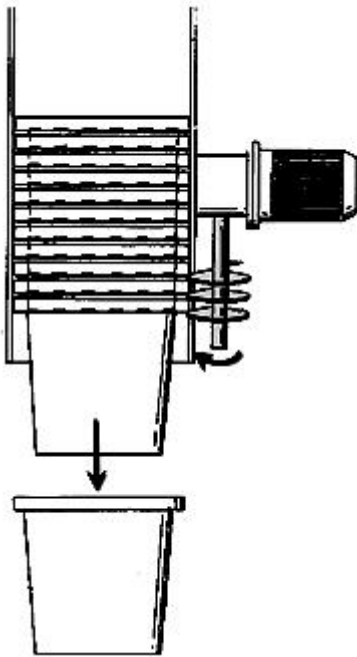
**B65G 59/12**

characterised by de-stacking during transit

**Definition statement**

*This place covers:*

Illustrative example of subject matter classified in this group:

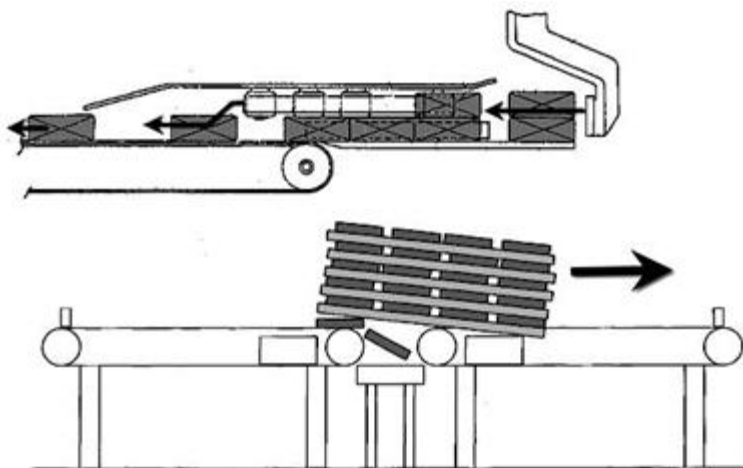

## B65G 60/00

### Simultaneously or alternatively stacking and de-stacking of articles

#### Definition statement

*This place covers:*

Illustrative example of subject matter classified in this group:

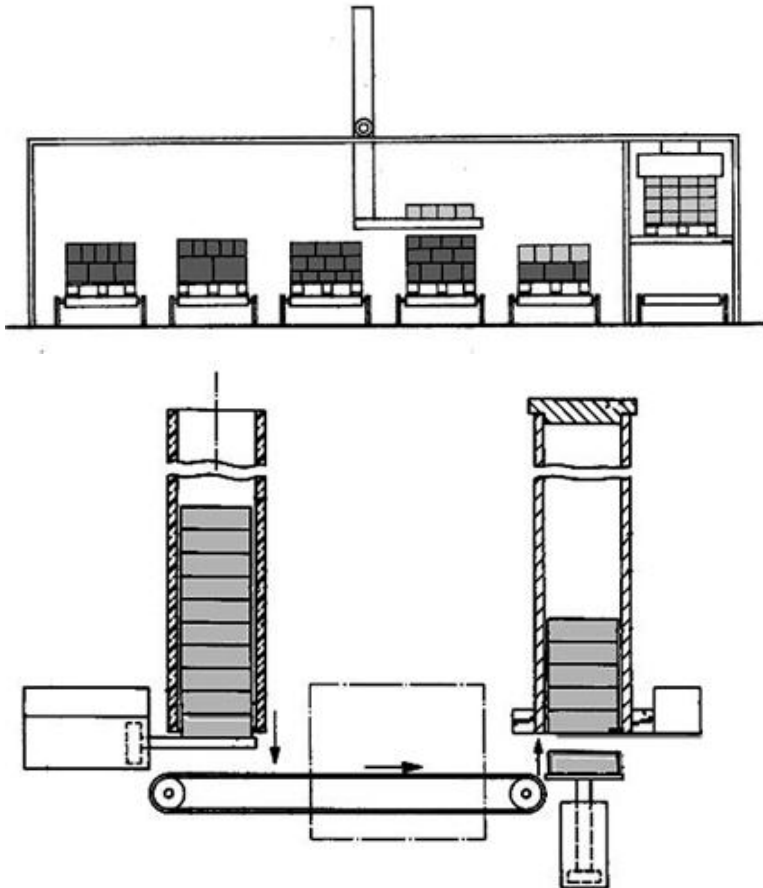

#### References

##### *Informative references*

*Attention is drawn to the following places, which may be of interest for search:*

De-stacking from the bottom of the stack by means of reciprocating or oscillating escapement-like mechanisms	<a href="#">B65G 2814/03</a>
General arrangements	<a href="#">B65G 2814/0301</a>
Central control devices	<a href="#">B65G 2814/0302</a>

## B65G 61/00

Use of pick-up or transfer devices or of manipulators for stacking or de-stacking articles not otherwise provided for

### Definition statement

*This place covers:*

Illustrative example of subject matter classified in this group:

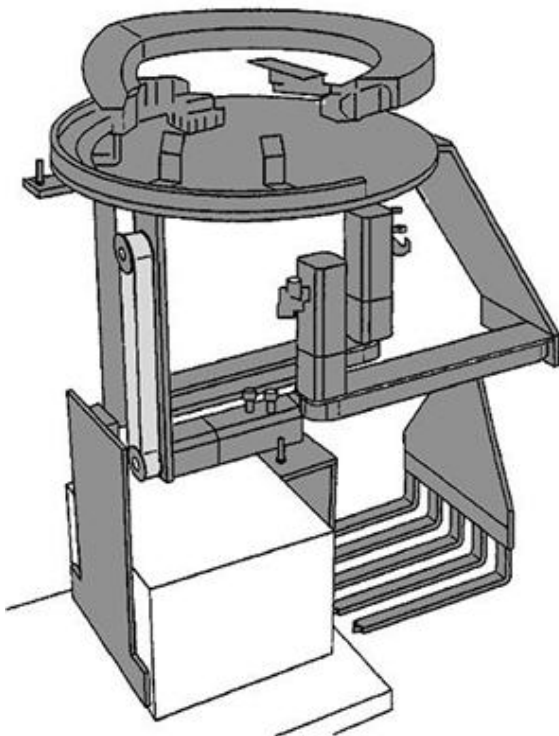
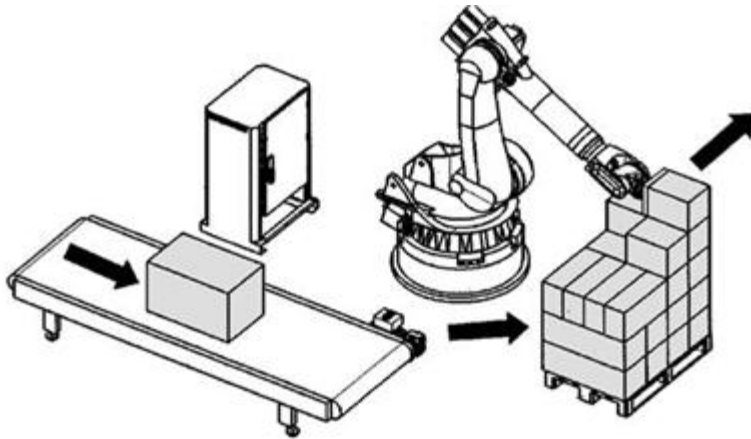

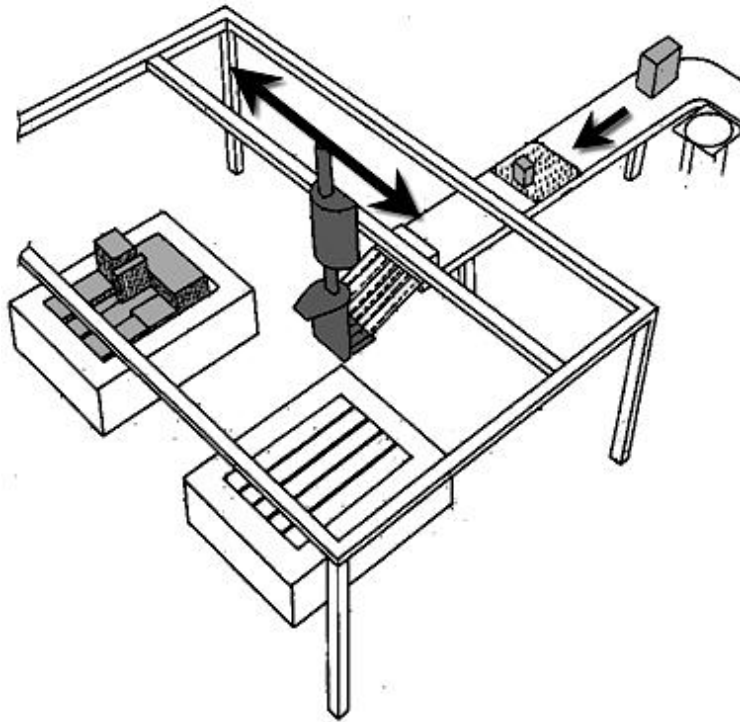

## References

### Informative references

Attention is drawn to the following places, which may be of interest for search:

Use of pick-up or transfer devices or of manipulators for stacking or de-stacking articles not otherwise provided for	<a href="#">B65G 61/00</a>
Manipulators	<a href="#">B25J</a>
Gantry type manipulation	<a href="#">B25J 9/1615</a>
Digital computers in general; Data processing equipment in general	<a href="#">G06F 15/00</a>
Digital computing or data processing equipment or methods	<a href="#">G06F 17/00</a>

## B65G 63/00

**Transferring or trans-shipping at storage areas, railway yards or harbours {or in opening mining cuts}; Marshalling yard installations**

## References

### Informative references

Attention is drawn to the following places, which may be of interest for search:

Transferring of refuse between vehicles or containers	<a href="#">B65F 9/00</a>
Dredging, soil shifting	<a href="#">E02F</a>
Conveyors used in co-operation with coal or like winning apparatus	<a href="#">E21C 47/00</a>

## B65G 63/002

{for articles}

### Definition statement

*This place covers:*

The articles are palletised or are single pieces moved one at a time like rolls of web material. They can be also carriages or vehicle bodies on special pallets.

Containers in the sense of [B65G 63/00](#) are ISO containers or freight/cargo/transport containers 20 and 40 foot.

Bulk is dry bulk materials such as corn, sugar, sand, coal, rock, cellulosic materials like wood chips and the like, fertilizer, cement, and the like, seed, rock salt, pharmaceuticals, chemicals, commodities, screws, nuts, bolts and the like, but could be anything, like ball bearings, or widgets.

Illustrative example of subject matter classified in this group:

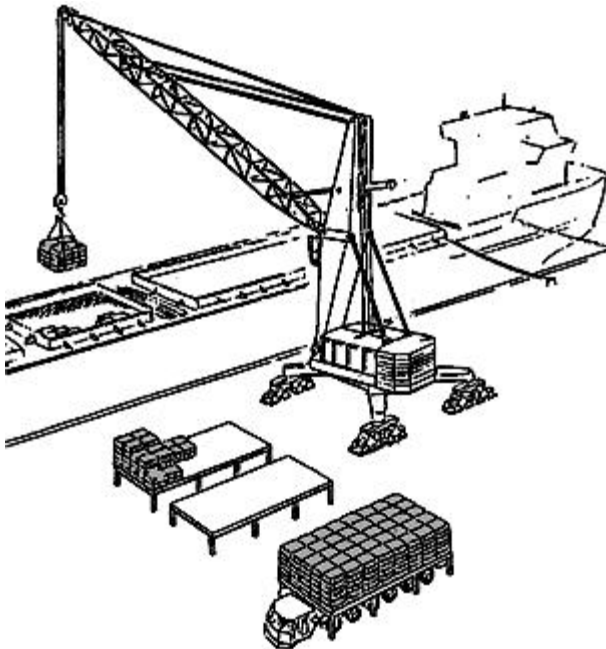

## B65G 63/004

{for containers}

### Definition statement

*This place covers:*

Containers in the sense of [B65G 63/00](#) are ISO containers or freight/cargo/transport containers 20 and 40 foot.



Illustrative example of subject matter classified in this group:

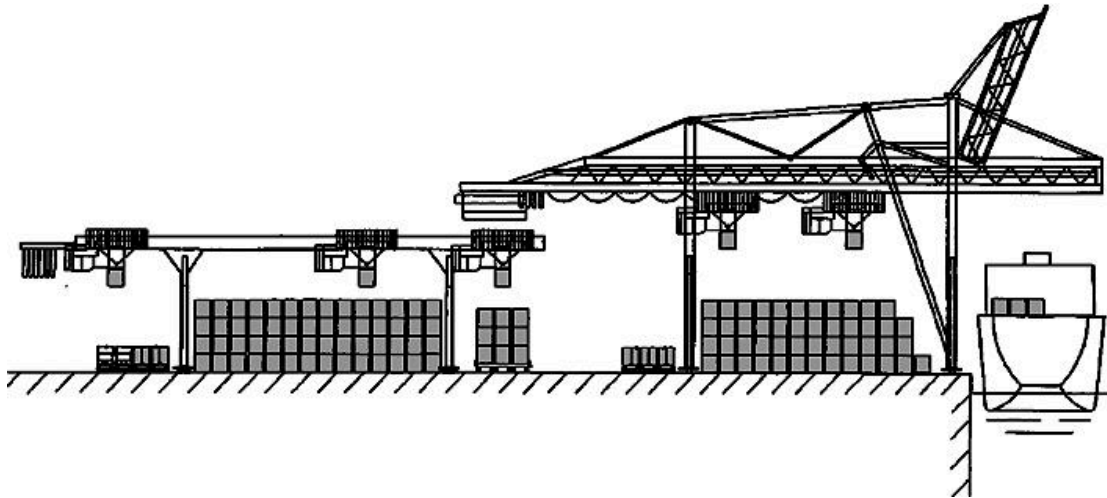

## **B65G 63/006**

{using slanted guides}

### **Definition statement**

*This place covers:*

Illustrative example of subject matter classified in this group:

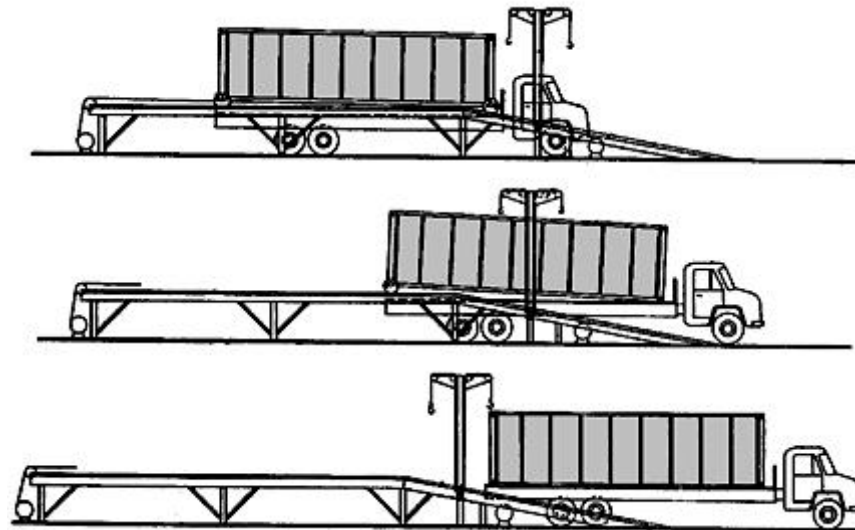

## **B65G 63/008**

**{for bulk material}**

### **Definition statement**

*This place covers:*

Illustrative example of subject matter classified in this group:

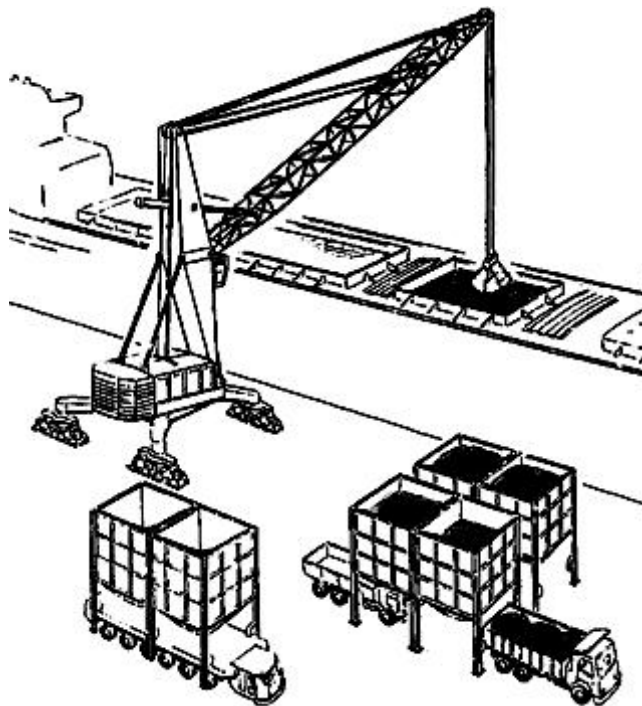

## **B65G 63/02**

**with essentially horizontal transit otherwise than by bridge**

### **Definition statement**

*This place covers:*

No essential vertical displacement (only limited lift action) - horizontally supported from under and travels horizontally

Illustrative example of subject matter classified in this group:

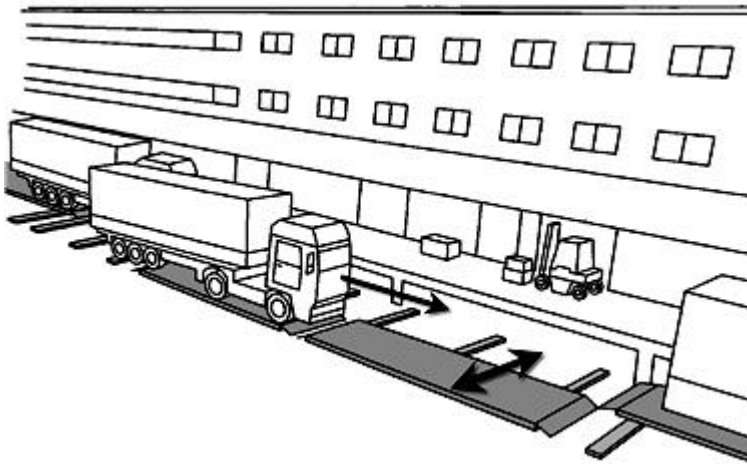

## **B65G 63/022**

{for articles}

### **Definition statement**

*This place covers:*

The articles are palletised or are single pieces moved one at a time like rolls of web material .They can be also carriages or vehicle bodies on special pallets.

Illustrative example of subject matter classified in this group:

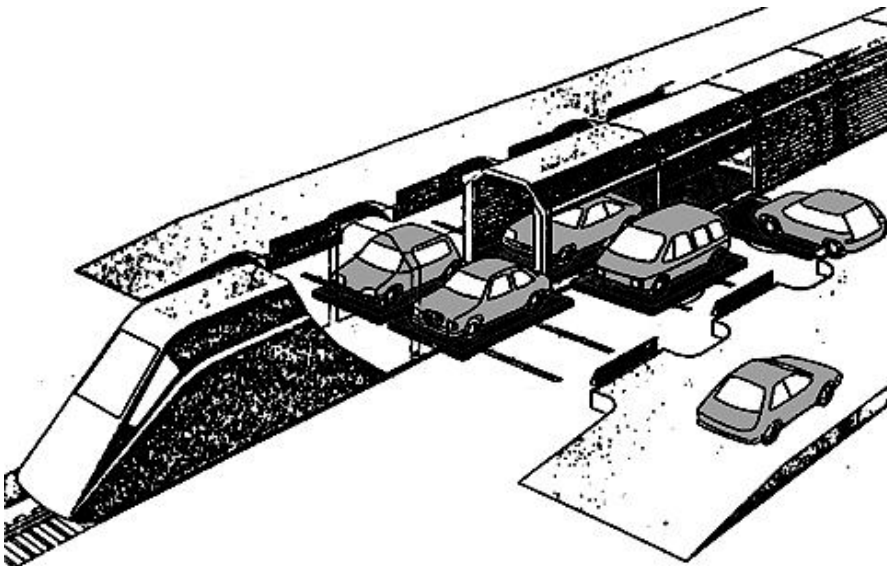

## **B65G 63/025**

{for containers}

### **Definition statement**

*This place covers:*

Containers in the sense of [B65G 63/00](#) are ISO containers or freight/cargo/transport containers 20 and 40 foot.

Illustrative example of subject matter classified in this group:

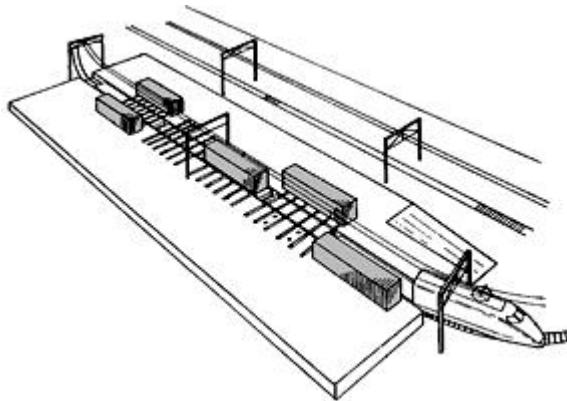

## **B65G 63/027**

**{for bulk material}**

### **Definition statement**

*This place covers:*

Bulk is dry bulk materials such as corn, sugar, sand, coal, rock, cellulosic materials like wood chips and the like, fertilizer, cement, and the like, seed, rock salt, pharmaceuticals, chemicals, commodities, screws, nuts, bolts and the like, but could be anything, like ball bearings, or widgets.

Illustrative example of subject matter classified in this group:

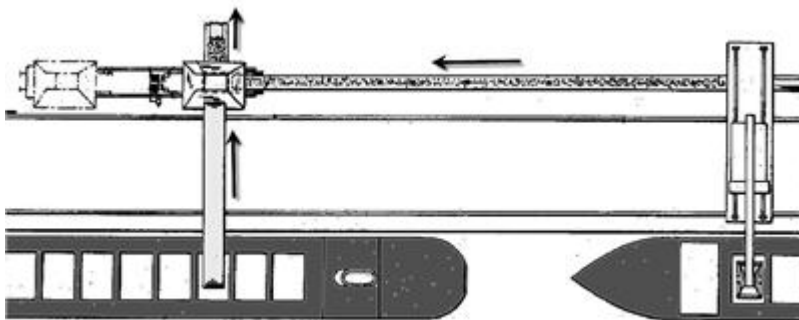

## **B65G 63/04**

**with essentially-horizontal transit by bridges equipped with conveyors**

### **Definition statement**

*This place covers:*

Load is suspended and travels horizontally

### **References**

#### **Informative references**

*Attention is drawn to the following places, which may be of interest for search:*

Skips	<a href="#">B66B 17/26</a>
Cranes	<a href="#">B66C</a>

## B65G 63/042

{for articles}

### Definition statement

*This place covers:*

Illustrative example of subject matter classified in this group:

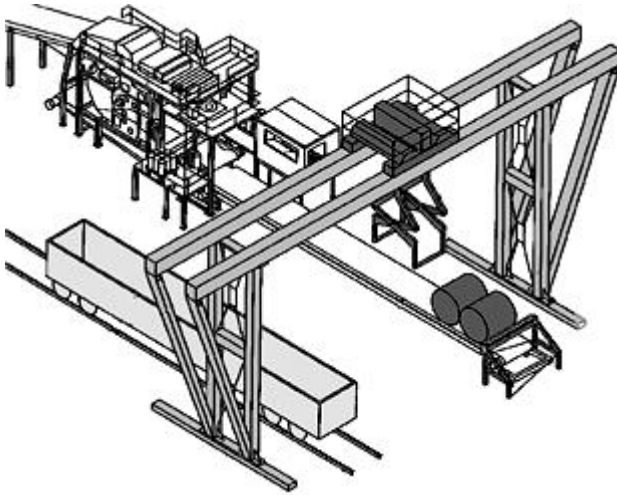

## B65G 63/045

{for containers}

### Definition statement

*This place covers:*

Illustrative example of subject matter classified in this group:

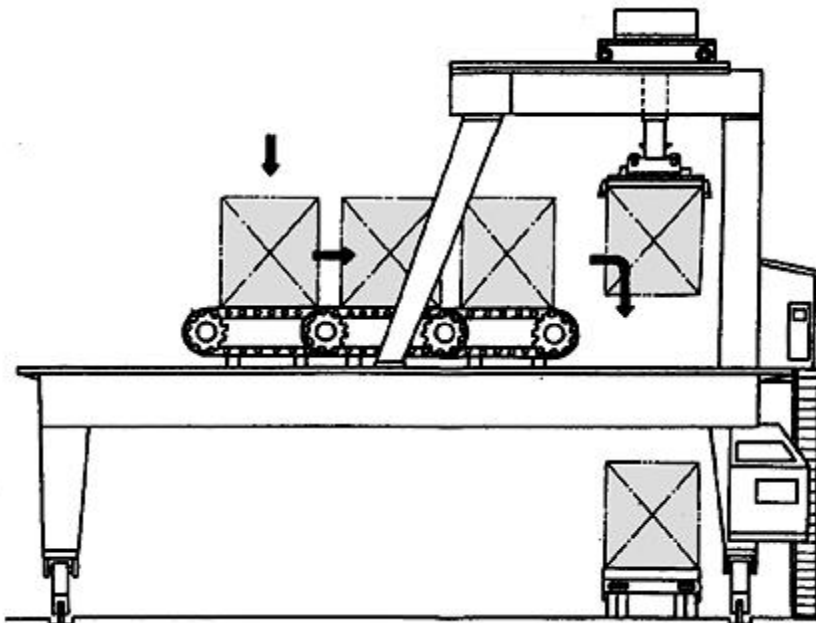

**B65G 63/047****{for bulk material}****Definition statement***This place covers:*

Illustrative example of subject matter classified in this group:

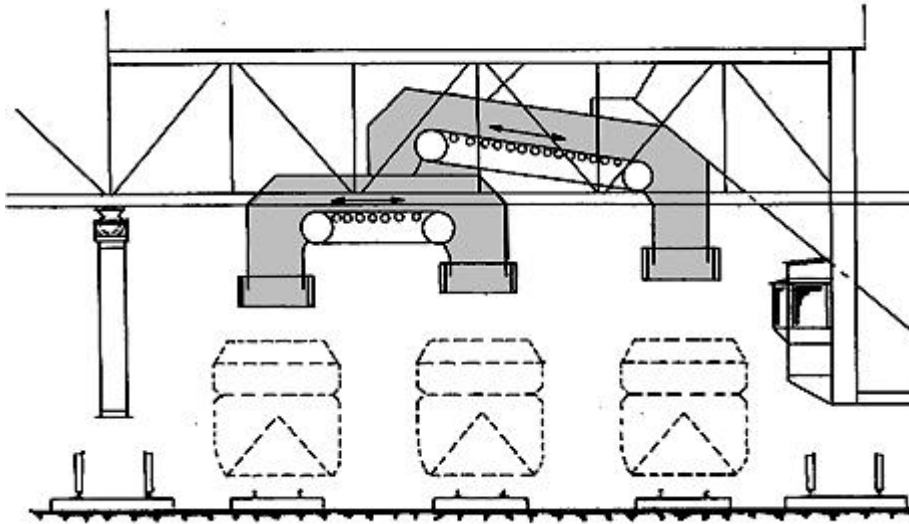
**References****Informative references***Attention is drawn to the following places, which may be of interest for search:*

Piling or unpling loose materials in bulk, e.g. coal, manure, timber, not otherwise provided for	<a href="#">B65G 65/28</a>
Loading or unloading ships using devices specially adapted for bulk material	<a href="#">B65G 67/606</a>

**B65G 63/065****{for containers}****Definition statement***This place covers:*

Illustrative example of subject matter classified in this group:

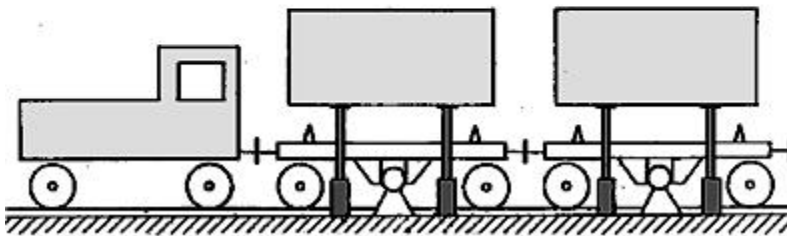
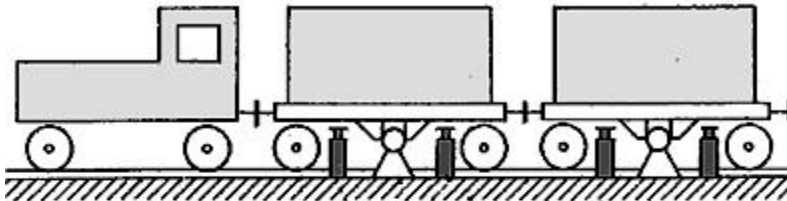
**References****Limiting references***This place does not cover:*

Using slanted guides	<a href="#">B65G 63/006</a>
----------------------	-----------------------------

**Informative references***Attention is drawn to the following places, which may be of interest for search:*

Legs, e.g. detachable	<a href="#">B65D 90/14</a>
-----------------------	----------------------------



## B65G 63/067

{for bulk material}

### Definition statement

*This place covers:*

Illustrative example of subject matter classified in this group:

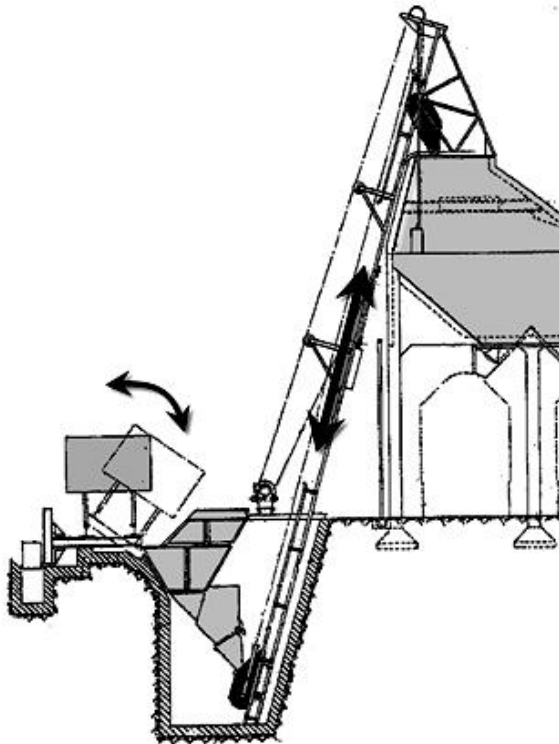
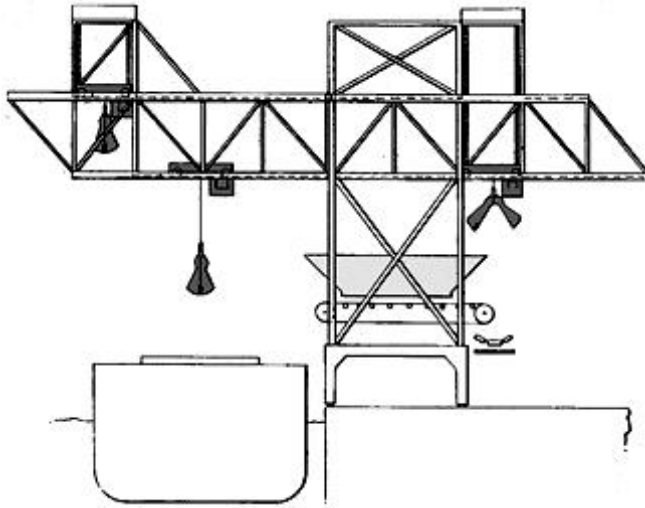



## B65G 65/00

Loading or unloading (of vehicles [B65G 67/00](#))

### Definition statement

*This place covers:*

Illustrative example of subject matter classified in this group:

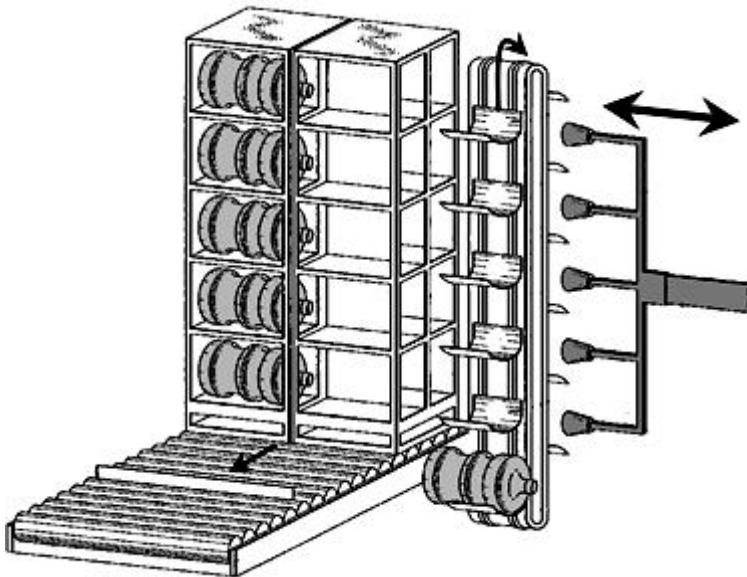
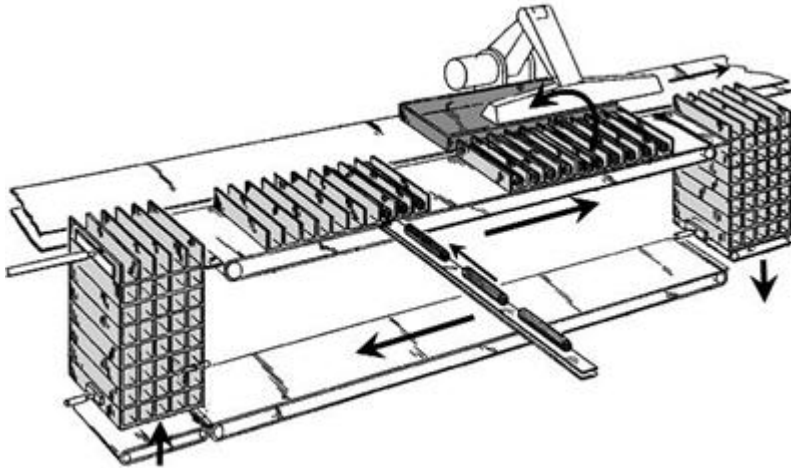

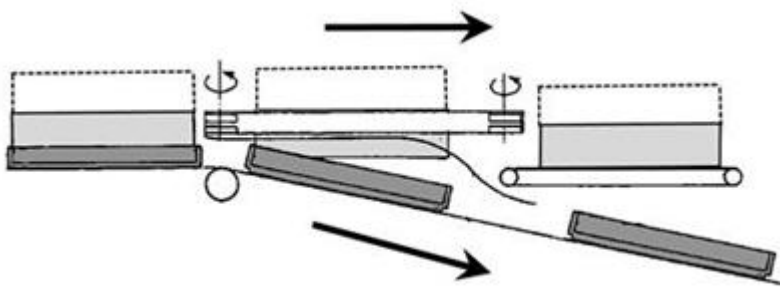
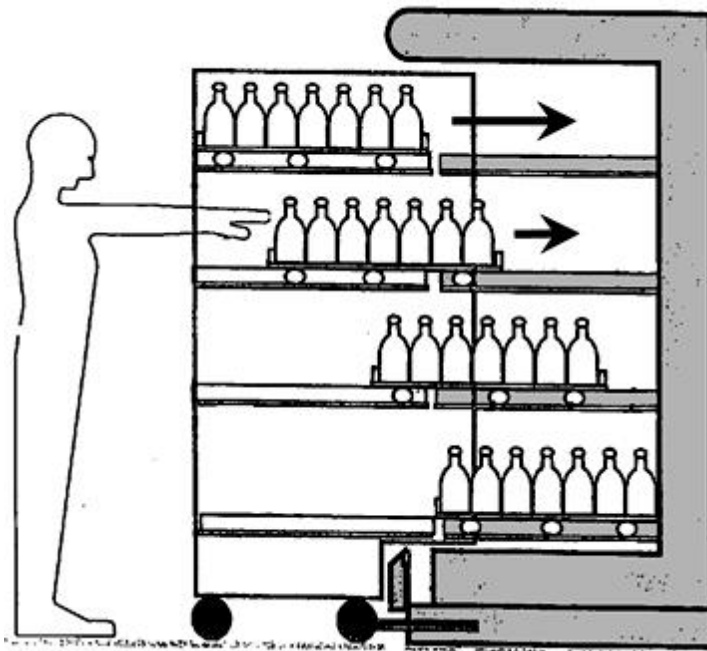

**References**

**Limiting references**

*This place does not cover:*

Loading/unloading vehicles, piling	<a href="#">B65G 67/00</a>
------------------------------------	----------------------------

**Informative references**

*Attention is drawn to the following places, which may be of interest for search:*

Feeding or discharging conveyors by devices incorporated in, or operatively associated with, conveyors	<a href="#">B65G 47/00</a>
Loading or unloading	<a href="#">B65G 65/00</a>
Loading or unloading articles or bulk materials	<a href="#">B65G 2814/0217</a> - <a href="#">B65G 2814/0235</a>
Loading or unloading means	<a href="#">B65G 2814/0314</a> - <a href="#">B65G 2814/0343</a>

## B65G 65/02

Loading or unloading machines comprising essentially a conveyor for moving the loads associated with a device for picking-up the loads

### Definition statement

*This place covers:*

Illustrative example of subject matter classified in this group:

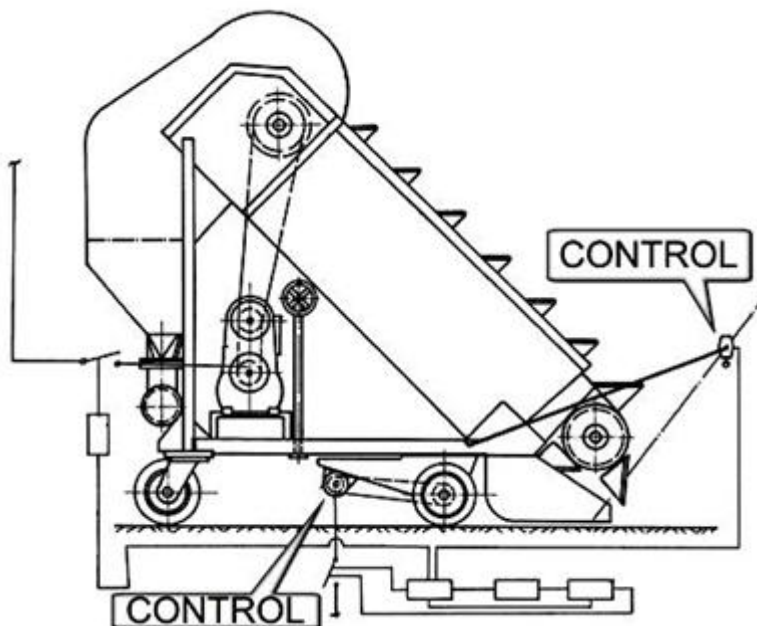
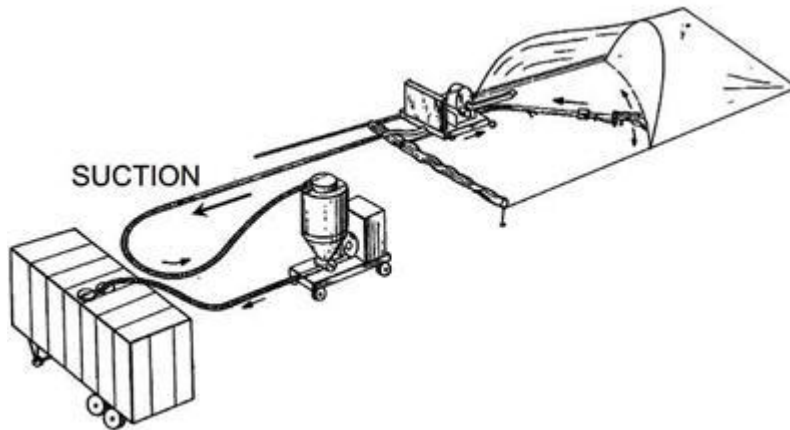

### References

#### Informative references

Attention is drawn to the following places, which may be of interest for search:

Suction take-up	<a href="#">B65G 53/00</a>
-----------------	----------------------------

**B65G 65/04**

with pick-up shovels (constructions of shovels [E02F](#))

**Definition statement**

*This place covers:*

With lift-up of the material

Illustrative example of subject matter classified in this group:

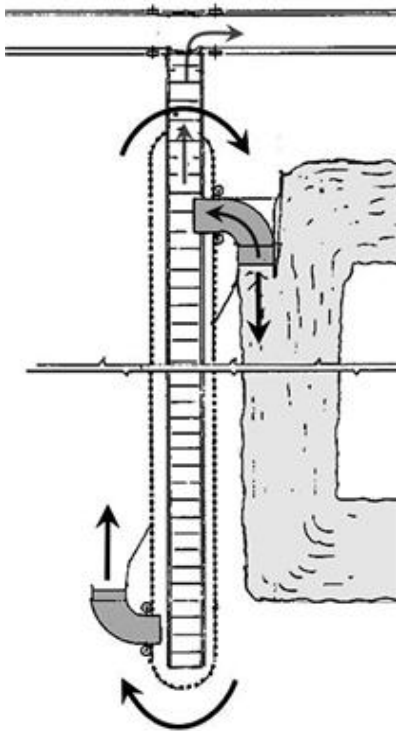
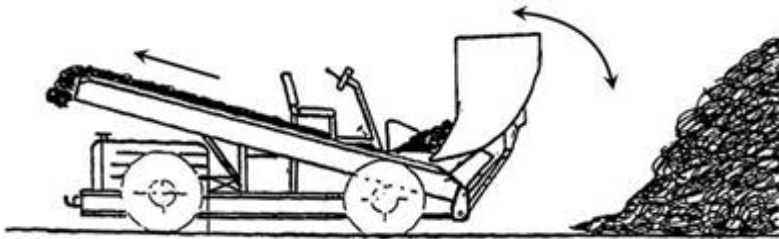
**References****Informative references**

Attention is drawn to the following places, which may be of interest for search:

Raking or scraping devices without lifting up	<a href="#">B65G 65/10</a>
Raking or scraping devices without lifting up	<a href="#">B65G 65/12</a>

## B65G 65/06

with endless scraping or elevating pick-up conveyors

### Definition statement

*This place covers:*

Illustrative examples of subject matter classified in this group:

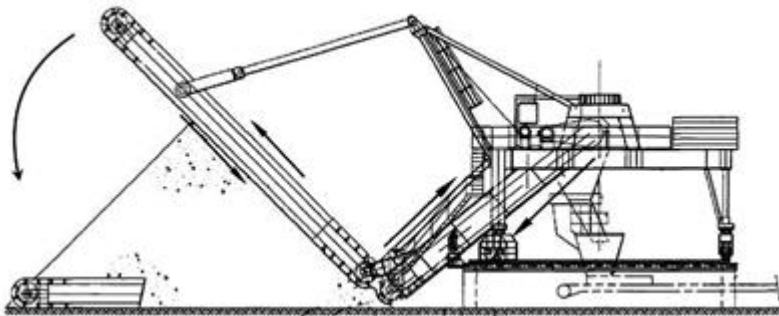
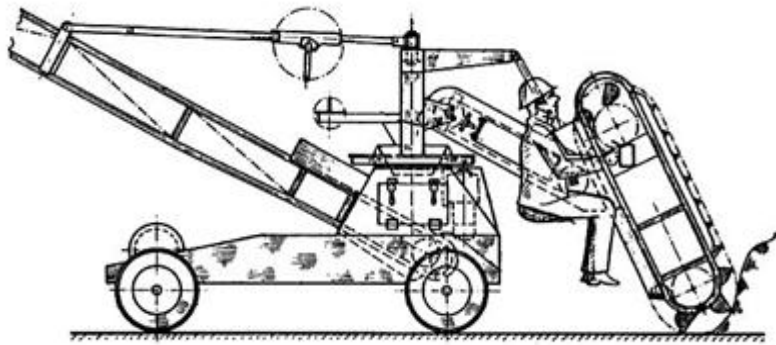

### References

#### Informative references

Attention is drawn to the following places, which may be of interest for search:

For silos	<a href="#">B65G 65/42</a>
For ships	<a href="#">B65G 67/606</a>
For fertilizers	<a href="#">C05F 17/943</a>

**B65G 65/10****Raking or scraping devices****Definition statement**

*This place covers:*

Illustrative example of subject matter classified in this group:

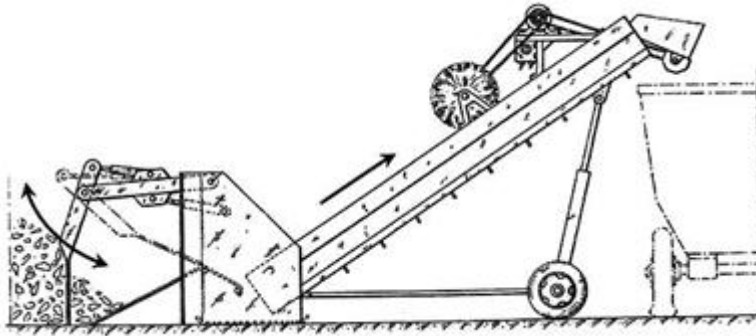
**References****Informative references**

*Attention is drawn to the following places, which may be of interest for search:*

The carrier or impeller having different forward and return paths or movement	<a href="#">B65G 25/02</a>
Using reciprocating conveyors	<a href="#">B65G 65/44</a>

**B65G 65/12****operations at positions off-set from the conveyor centreline****Definition statement**

*This place covers:*

Illustrative examples of subject matter classified in this group:

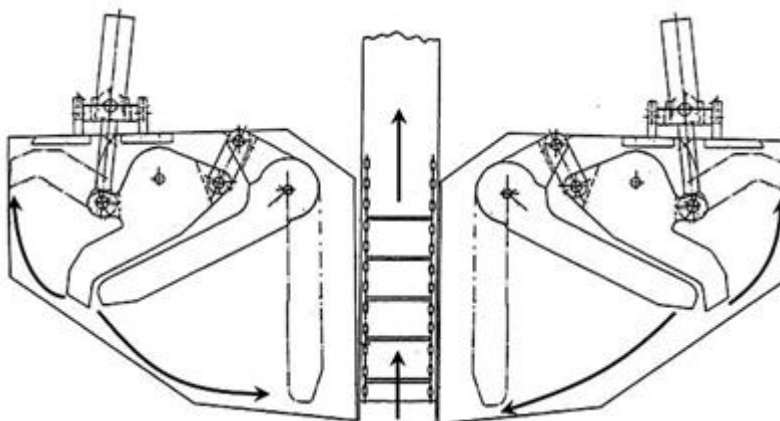



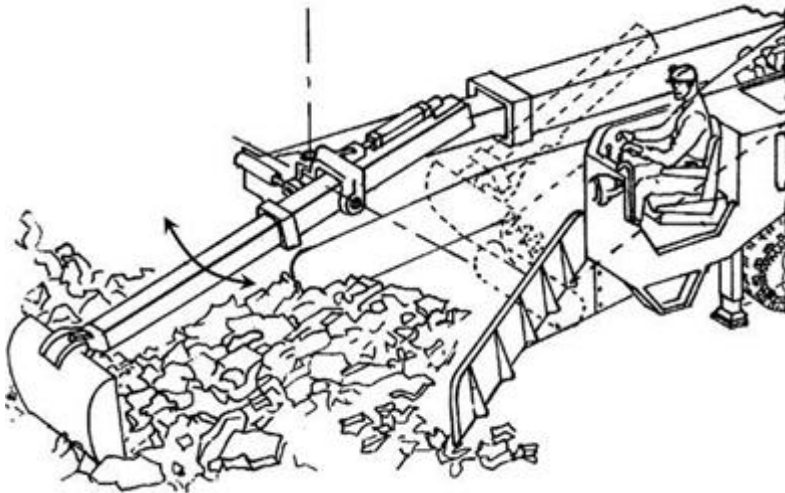

**B65G 65/14**

with jiggling pick-up conveyors, e.g. duck-bills

**Definition statement**

*This place covers:*

Illustrative examples of subject matter classified in this group:

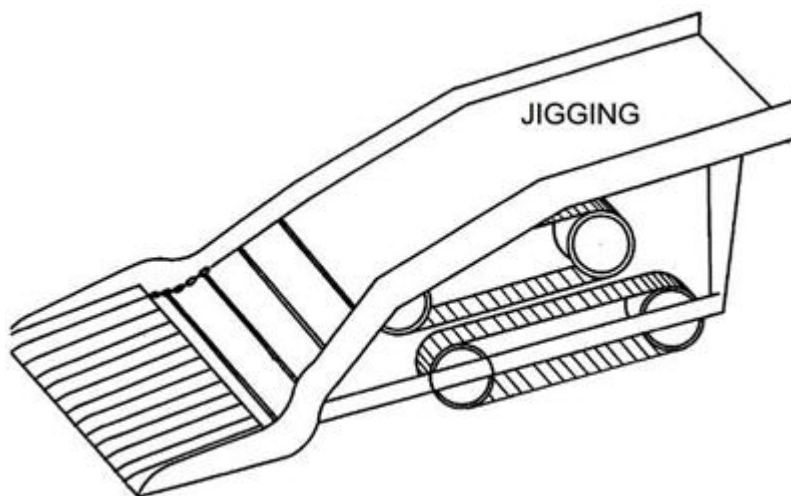
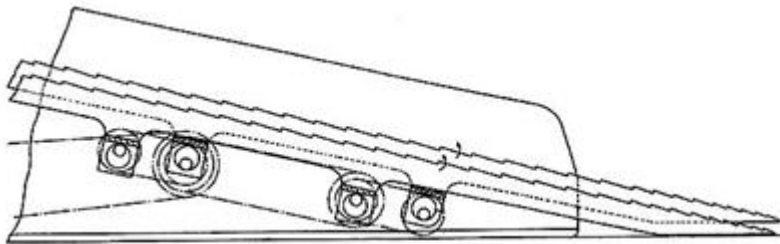

## B65G 65/16

with rotary pick-up conveyors

### Definition statement

*This place covers:*

Illustrative examples of subject matter classified in this group:

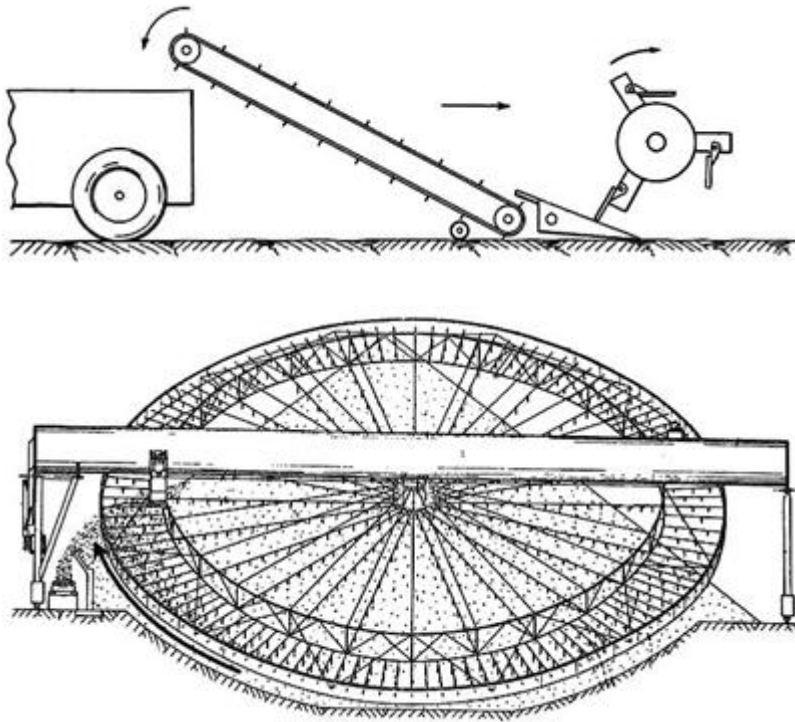



## B65G 65/18

### Discs

#### Definition statement

*This place covers:*

Illustrative example of subject matter classified in this group:

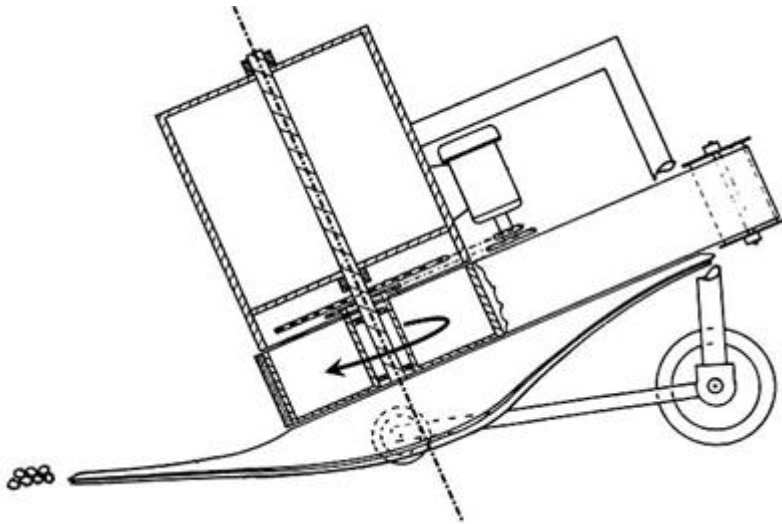

#### References

##### Informative references

Attention is drawn to the following places, which may be of interest for search:

Rotating arms	<a href="#">B65G 65/16</a>
Emptying bunkers	<a href="#">B65G 65/4836</a>

## B65G 65/20

### Paddle wheels

#### Definition statement

*This place covers:*

Illustrative example of subject matter classified in this group:

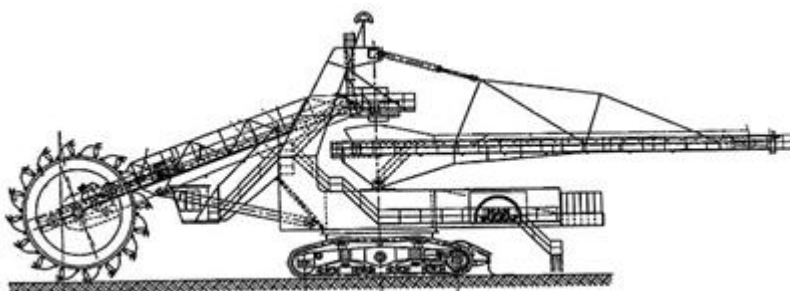

## References

### Informative references

Attention is drawn to the following places, which may be of interest for search:

Using other rotating means	<a href="#">B65G 65/48</a>
----------------------------	----------------------------

## B65G 65/22

### Screws

### Definition statement

This place covers:

Illustrative examples of subject matter classified in this group:

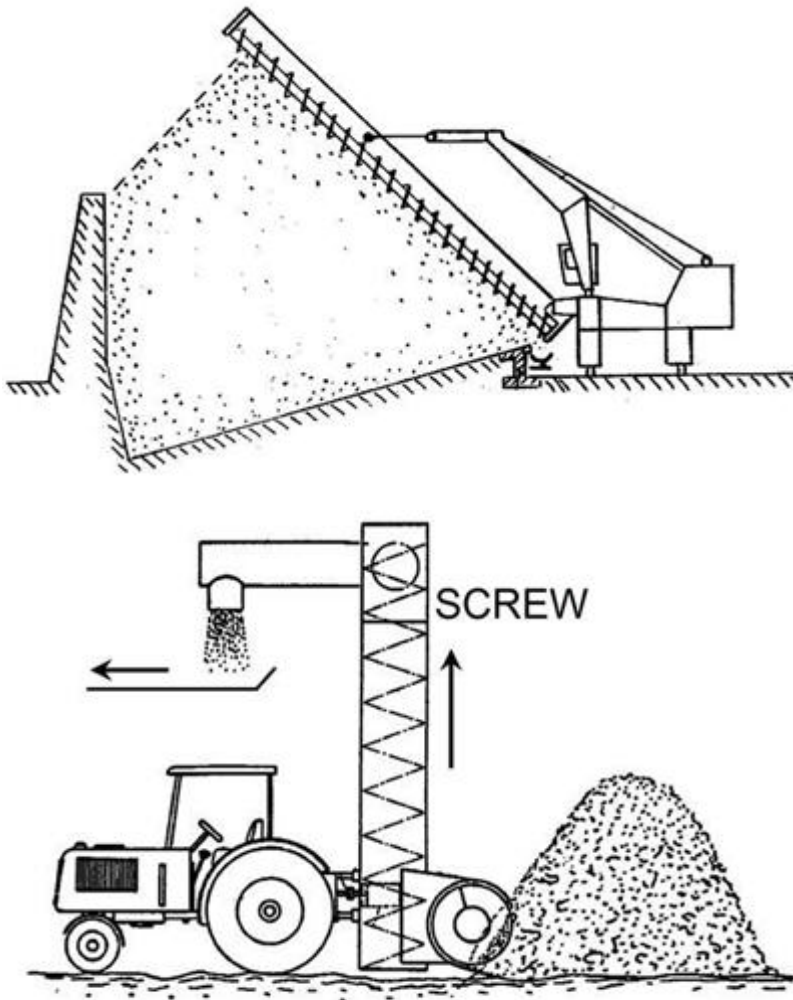

## References

### Informative references

Attention is drawn to the following places, which may be of interest for search:

Emptying bunkers	<a href="#">B65G 65/46</a>
------------------	----------------------------

## B65G 65/23

### Devices for tilting and emptying of containers

#### Definition statement

*This place covers:*

Illustrative examples of subject matter classified in this group:

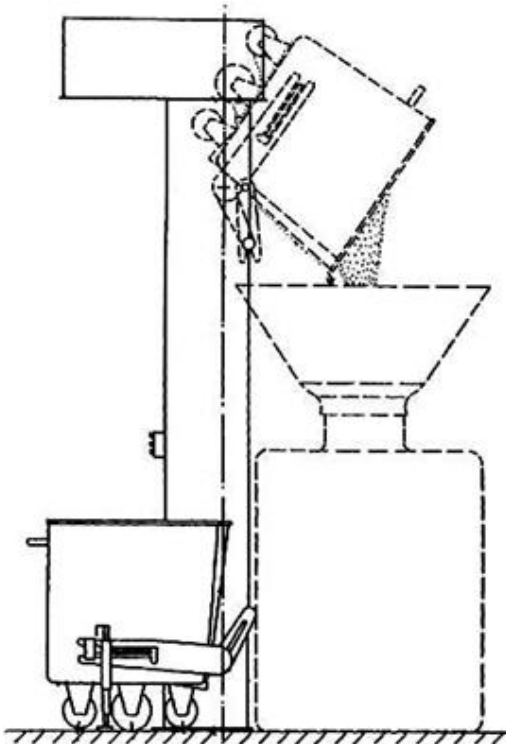

## References

### Informative references

Attention is drawn to the following places, which may be of interest for search:

Destacking after tilting	<a href="#">B65G 59/08</a>
Large containers filling or emptying by tilting	<a href="#">B65D 88/56</a>
Refuse, garbage	<a href="#">B65F</a>

## B65G 65/24

### for manual tilting of barrels or casks

#### Definition statement

This place covers:

Illustrative example of subject matter classified in this group:

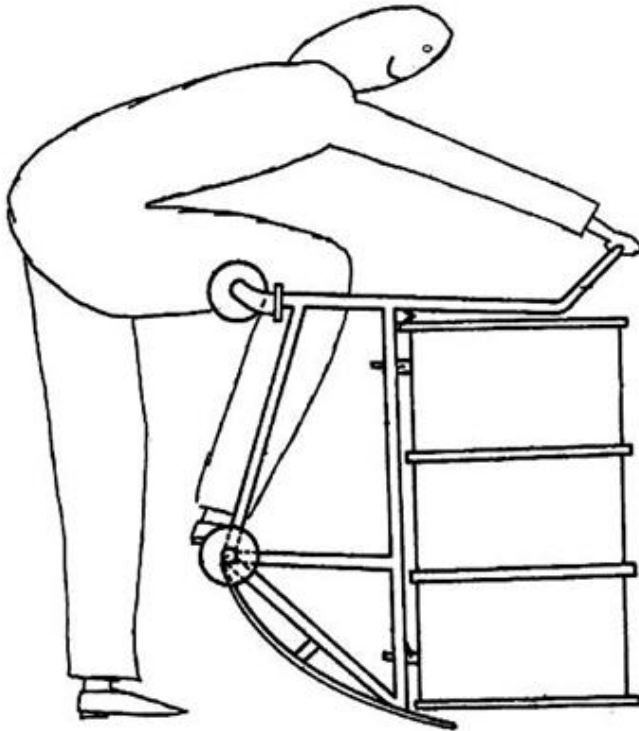

## References

### Informative references

Attention is drawn to the following places, which may be of interest for search:

Handling heavy material	<a href="#">B65G 7/08</a>
Machines, apparatus or devices for, or methods of, packaging articles or materials; unpacking	<a href="#">B65B</a>

## B65G 65/28

Piling or unpling loose materials in bulk, e.g. coal, manure, timber, not otherwise provided for (by soil-shifting or like equipment [E02F](#))

### Definition statement

*This place covers:*

Illustrative example of subject matter classified in this group:

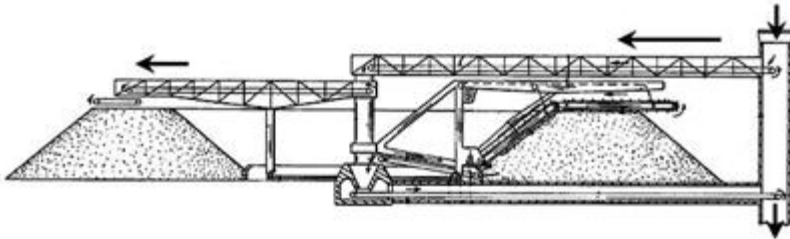

### References

#### *Informative references*

*Attention is drawn to the following places, which may be of interest for search:*

Transferring or trans-shipping for bulk materials	<a href="#">B65G 63/008</a>
Open pit mines	<a href="#">E21C 47/04</a>

**B65G 65/32****Filling devices****Definition statement**

*This place covers:*

Illustrative example of subject matter classified in this group:

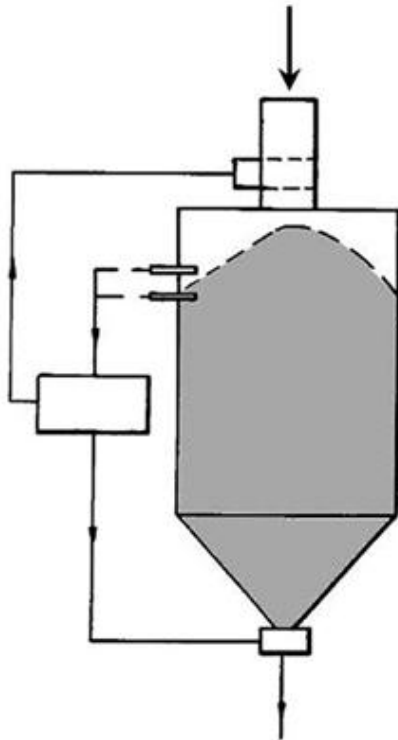
**References****Informative references**

*Attention is drawn to the following places, which may be of interest for search:*

Pneumatic conveyors	<a href="#">B65G 51/00</a> , <a href="#">B65G 53/00</a>
Auxiliary measures taken, or devices used, in connection with loading or unloading	<a href="#">B65G 69/00</a>
Filling reactors	<a href="#">B01J 8/0015</a>
Large containers	<a href="#">B65D 88/00</a>

## B65G 65/34

Emptying devices (conveyor construction [B65G 15/00](#) - [B65G 35/00](#); devices similar to vehicle tipplers [B65G 67/48](#))

### Definition statement

*This place covers:*

Illustrative examples of subject matter classified in this group:

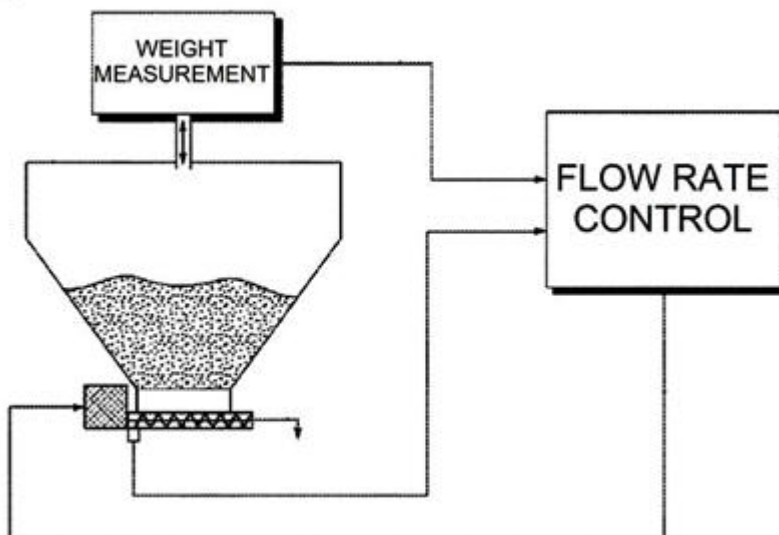
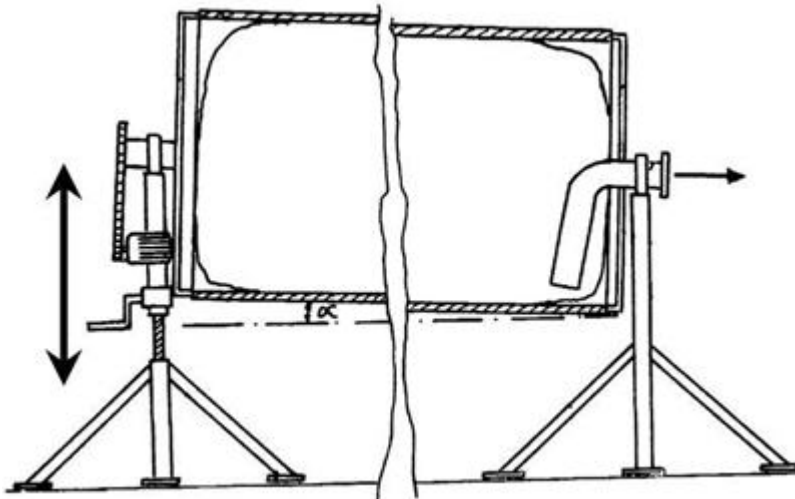

### References

#### Limiting references

*This place does not cover:*

Conveyor constructions	<a href="#">B65G 15/00</a> - <a href="#">B65G 35/00</a>
Devices similar to vehicle tipplers	<a href="#">B65G 67/48</a>

**B65G 65/36****Devices for emptying from the top****Definition statement**

*This place covers:*

Illustrative examples of subject matter classified in this group:

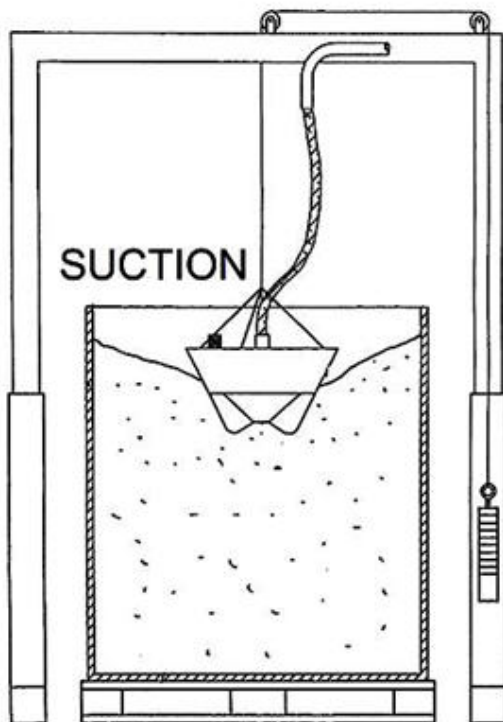
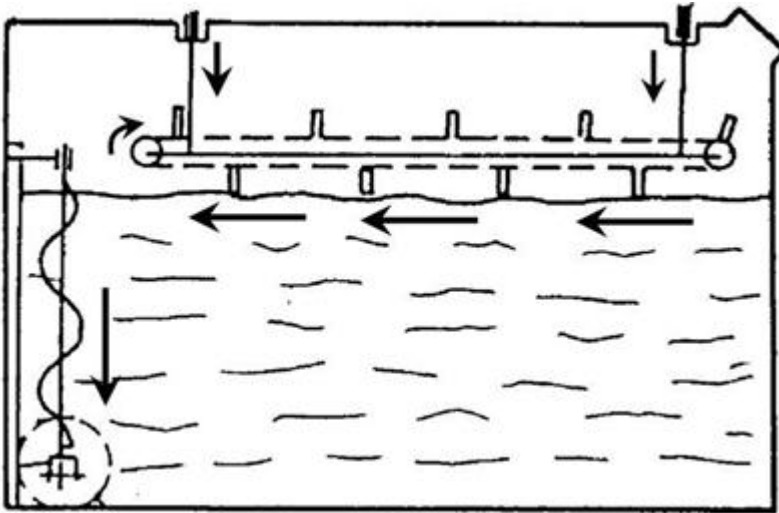
**References****Informative references**

*Attention is drawn to the following places, which may be of interest for search:*

Almost identical	<a href="#">B65G 65/38</a>
------------------	----------------------------



Silage	<a href="#">A01F 25/20</a>
Flexible Intermediate Bulk Container, unloading with suction	<a href="#">B65B 69/0075</a>

**B65G 65/365**

{comprising a vertical passage located inside the container}

**Definition statement**

*This place covers:*

Illustrative examples of subject matter classified in this group:

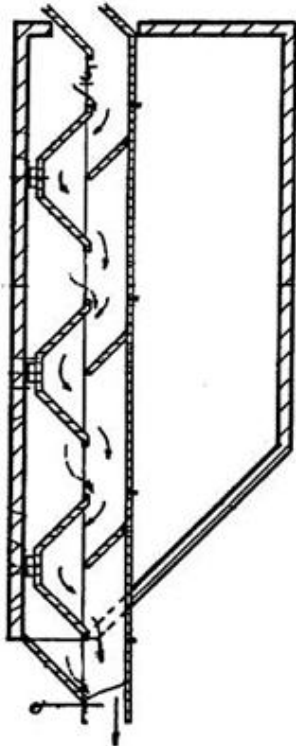

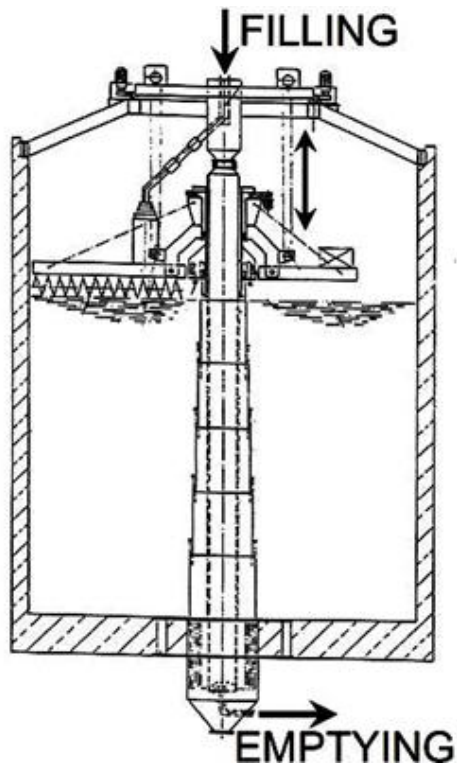

## References

### *Informative references*

Attention is drawn to the following places, which may be of interest for search:

Scraping devices	<a href="#">B65G 65/38</a>
------------------	----------------------------

## B65G 65/38

### Mechanical devices

### Definition statement

*This place covers:*

Devices include suction tubes and mouths, lifting screens (US2005100430), augers (US2005100430), rakes, blades, scraper conveyors (GB2036686) etc

Illustrative example of subject matter classified in this group:

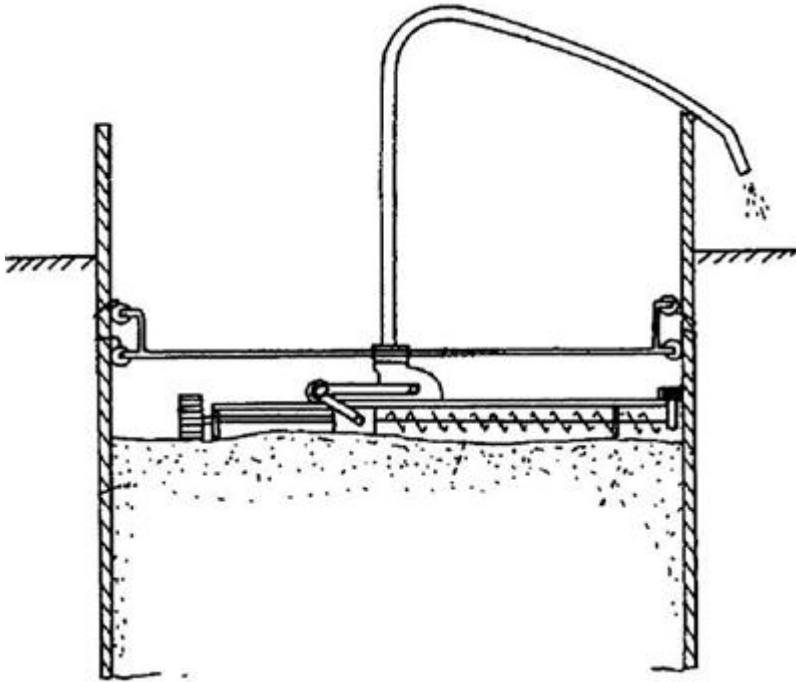

## References

### *Informative references*

*Attention is drawn to the following places, which may be of interest for search:*

Devices for emptying from the top	<a href="#">B65G 65/36</a>
Silage	<a href="#">A01F 25/20</a>

## **B65G 65/40**

### **Devices for emptying otherwise than from the top**

#### **Definition statement**

*This place covers:*

Emptying from the bottom or middle

Illustrative example of subject matter classified in this group:

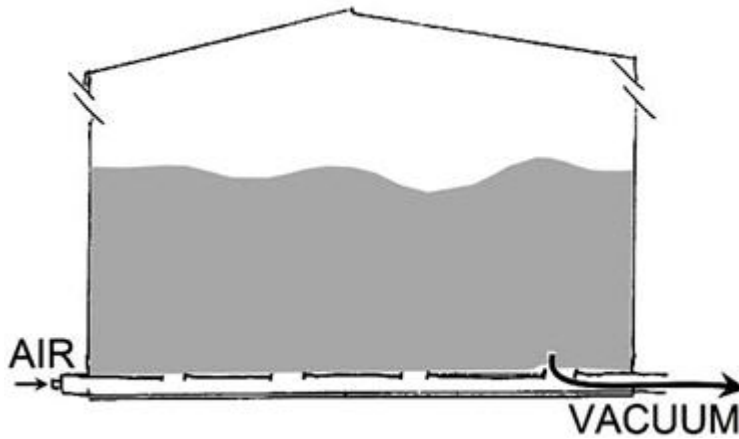

## References

### Informative references

Attention is drawn to the following places, which may be of interest for search:

Filling bags or small containers	<a href="#">B65B</a>
Gates or closures	<a href="#">B65D 90/54</a>

## B65G 65/42

using belt or chain conveyors

### Definition statement

*This place covers:*

For example: mobile frames to put UNDER the container

Illustrative examples of subject matter classified in this group:

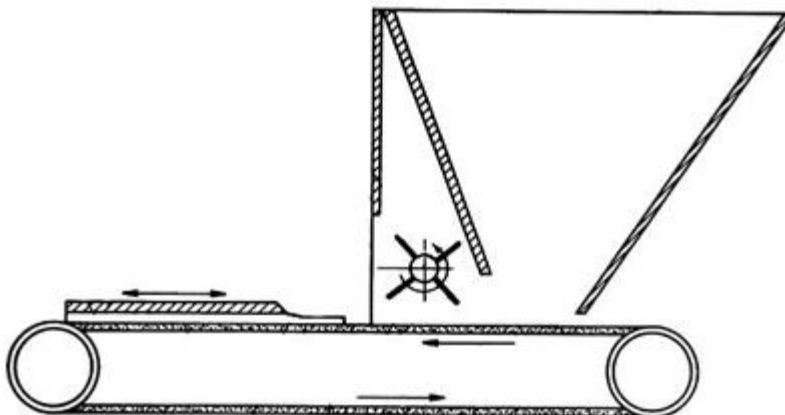

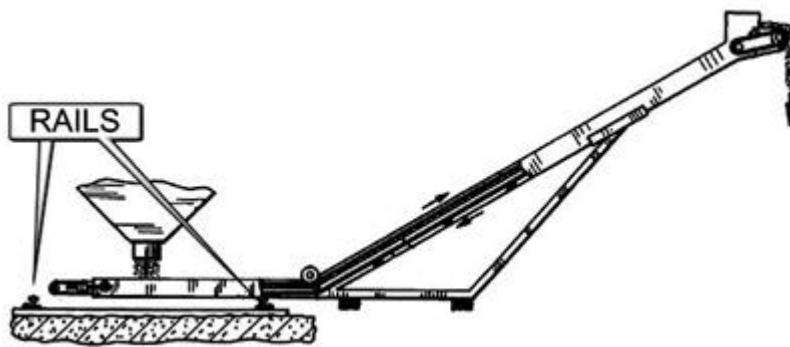

**B65G 65/425**

{arranged to be movable}

**Definition statement**

*This place covers:*

Movable on the bottom inside the container

Illustrative example of subject matter classified in this group:

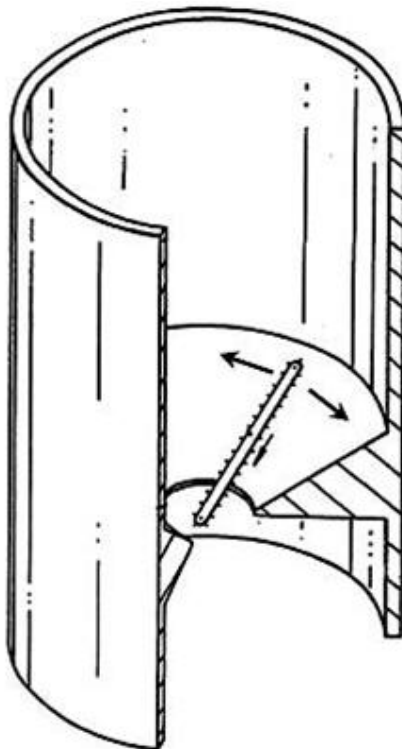

## B65G 65/44

using reciprocating conveyors, e.g. jiggling conveyors

### Definition statement

*This place covers:*

Illustrative examples of subject matter classified in this group:

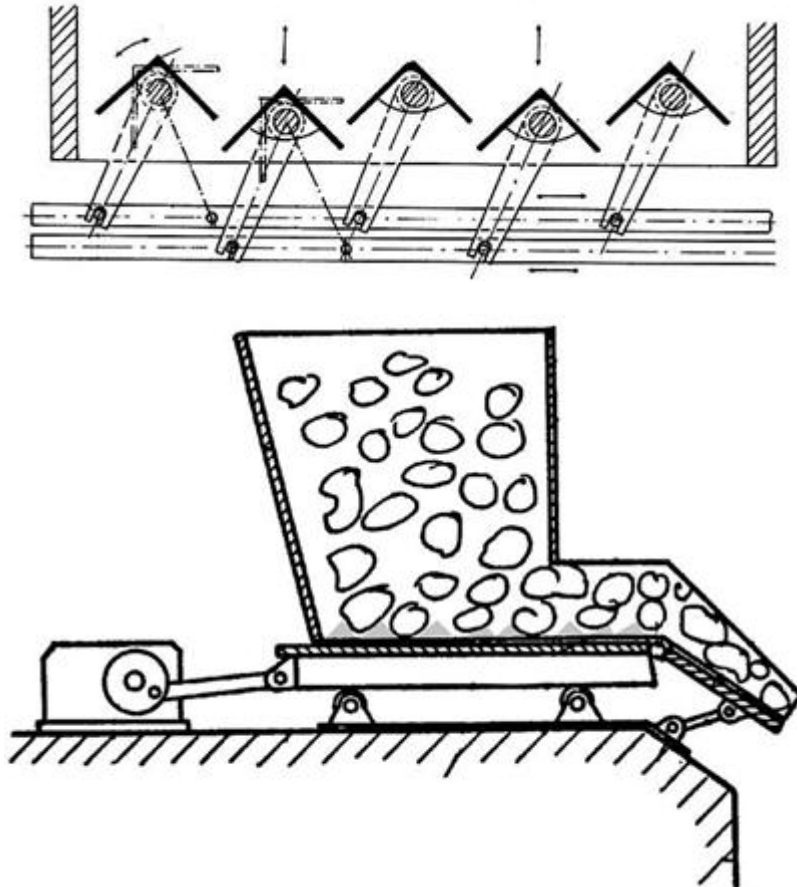

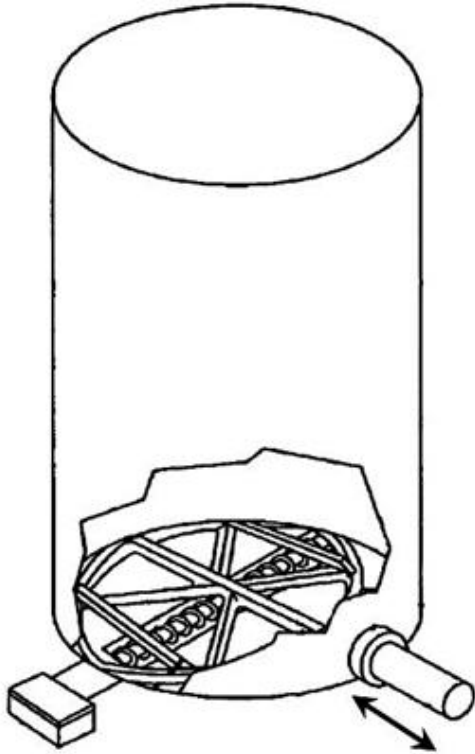

## References

### Informative references

Attention is drawn to the following places, which may be of interest for search:

Reciprocating along a vertical axis	<a href="#">B65G 65/4836</a>
Bridge preventing means	<a href="#">B65D 88/66</a>

## B65G 65/46

### using screw conveyors

#### Definition statement

This place covers:

Illustrative example of subject matter classified in this group:

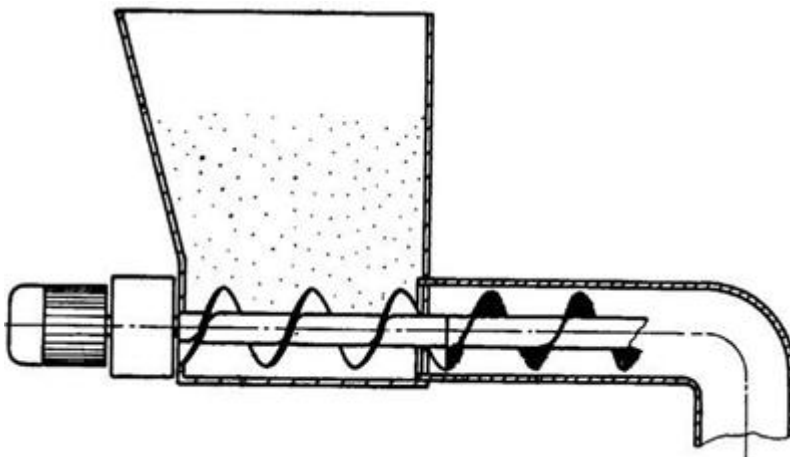

## References

### *Informative references*

Attention is drawn to the following places, which may be of interest for search:

Preventing bridge	<a href="#">B65D 88/68</a>
-------------------	----------------------------

## B65G 65/463

{arranged vertically or substantially vertically within the container  
([B65G 65/466](#) takes precedence)}

### Definition statement

*This place covers:*

Illustrative examples of subject matter classified in this group:

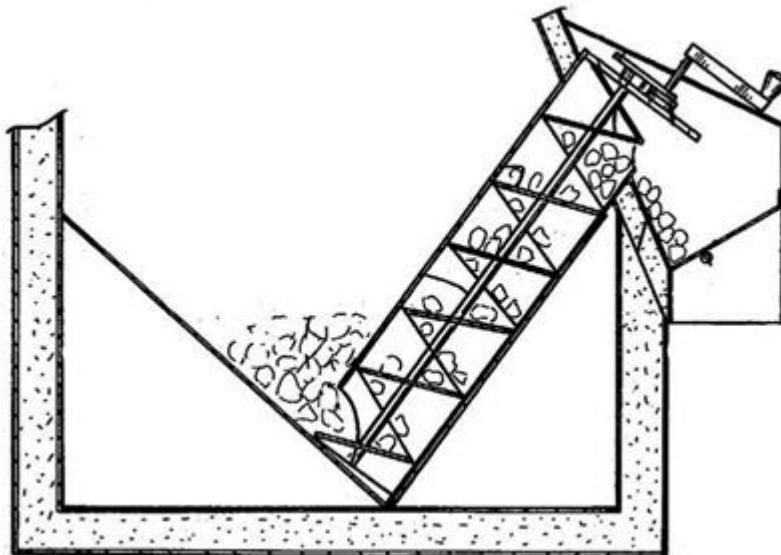



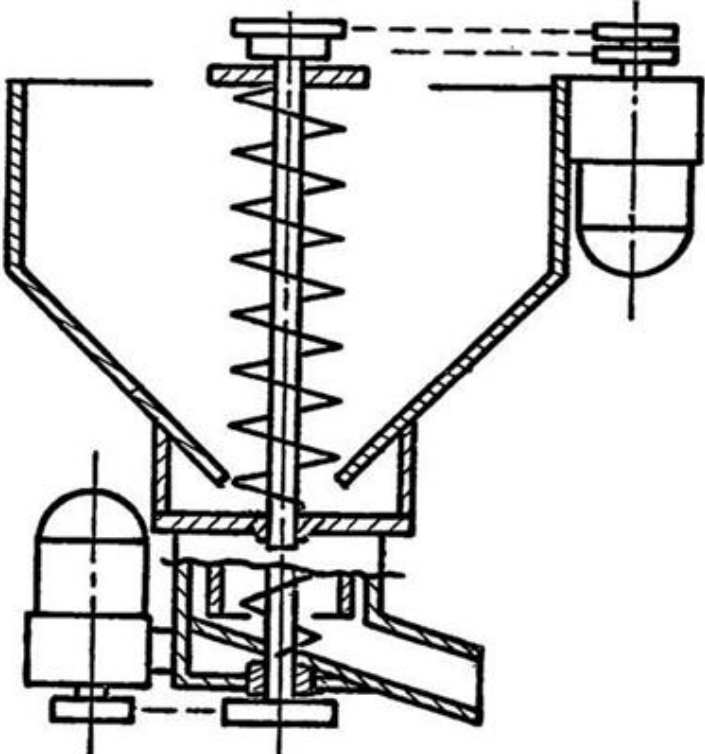

**References**

**Limiting references**

*This place does not cover:*

Arranged to be movable	<a href="#">B65G 65/466</a>
------------------------	-----------------------------

**B65G 65/466****{arranged to be movable}****Definition statement***This place covers:*

Illustrative example of subject matter classified in this group:

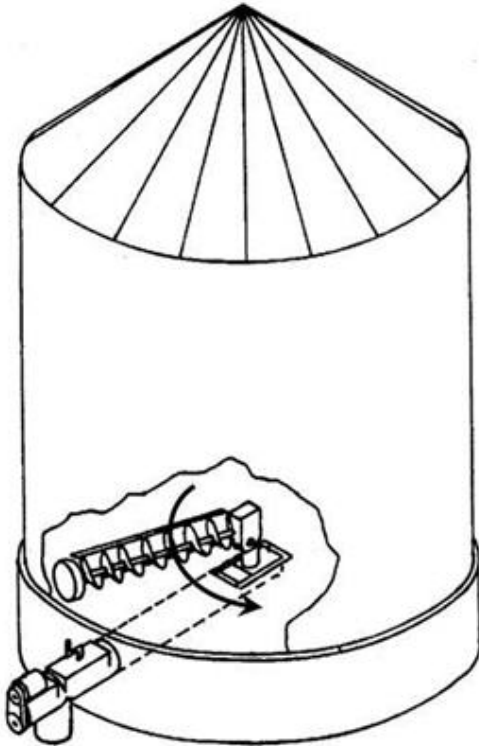
**References****Informative references***Attention is drawn to the following places, which may be of interest for search:*

Rotating or translating screw, movable vertical screw classified in	<a href="#">B65G 65/463</a> , <a href="#">B65G 65/466</a>
---------------------------------------------------------------------	--------------------------------------------------------------

## B65G 65/4809

{rotating about a substantially vertical axis}

### Definition statement

*This place covers:*

Illustrative examples of subject matter classified in this group:

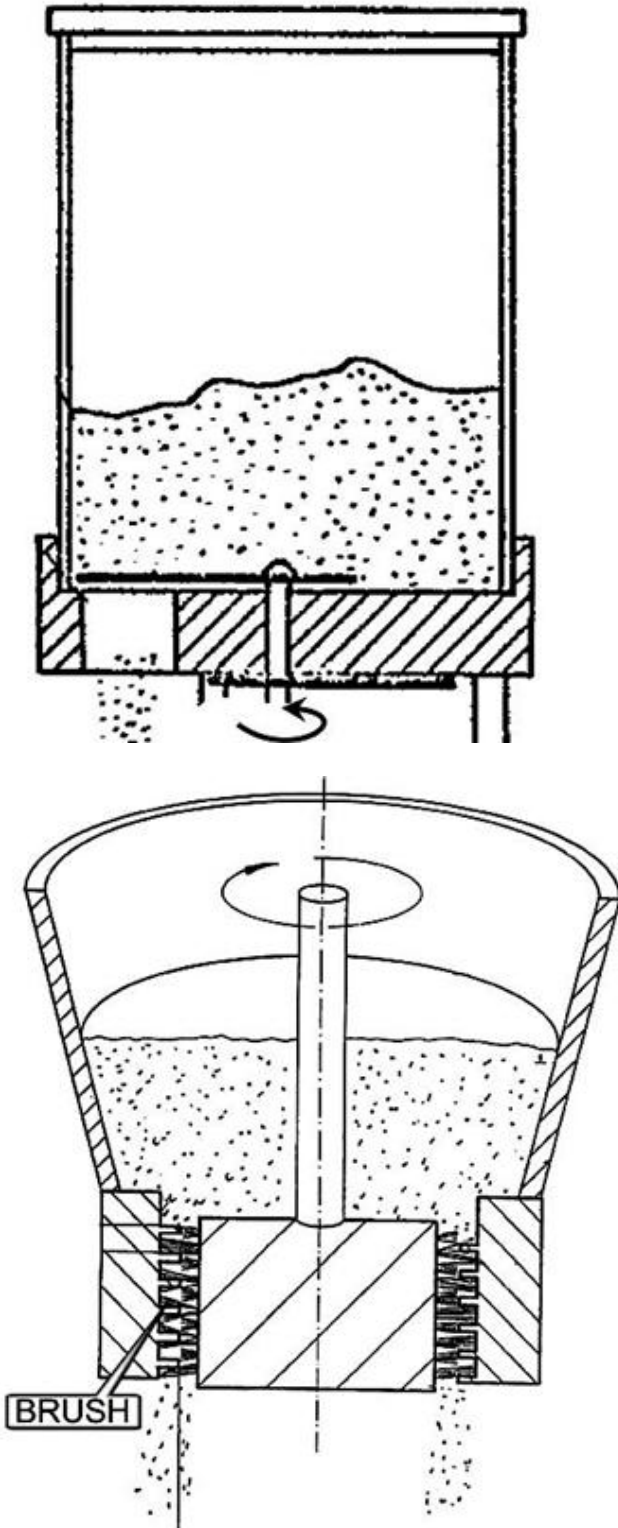

## References

### *Informative references*

Attention is drawn to the following places, which may be of interest for search:

Bridge preventing	<a href="#">B65D 88/68</a>
-------------------	----------------------------

## B65G 65/4818

{and having the form of rotating tables or pans}

### Definition statement

*This place covers:*

Illustrative examples of subject matter classified in this group:

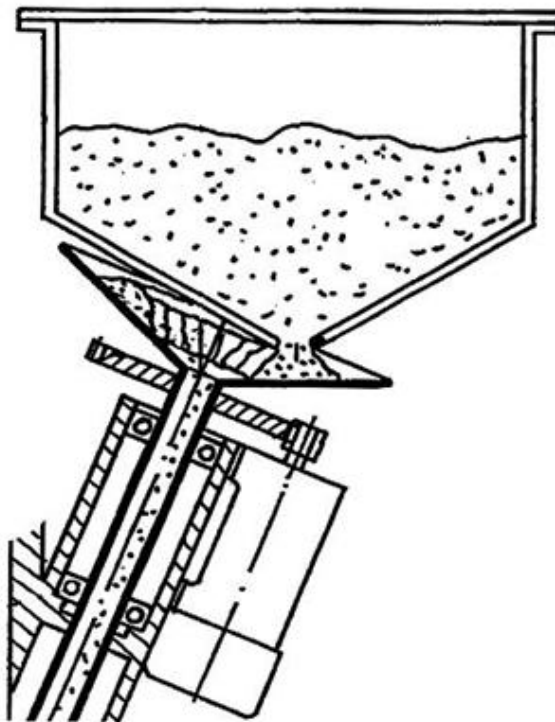

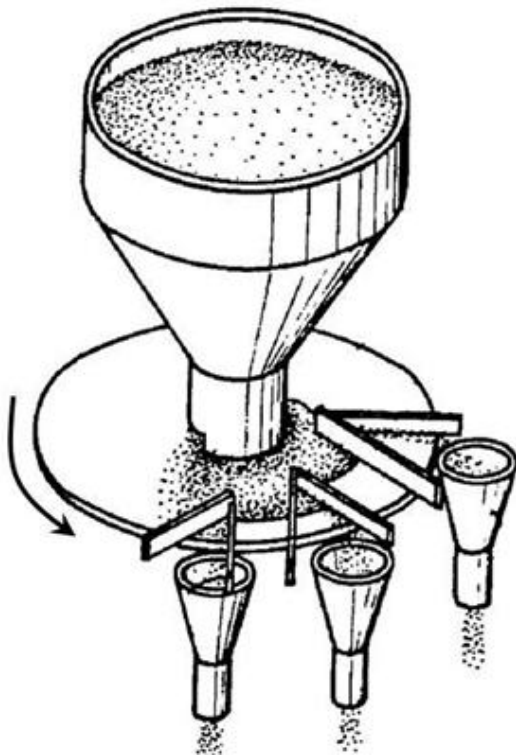

### B65G 65/4827

{with particular surface features, e.g. ribs, roughening}

#### Definition statement

*This place covers:*

Illustrative examples of subject matter classified in this group:

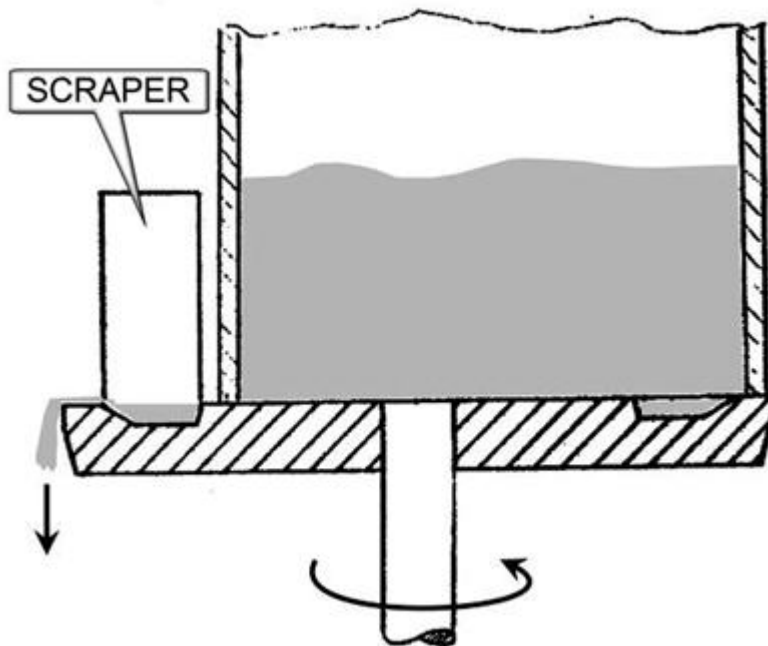

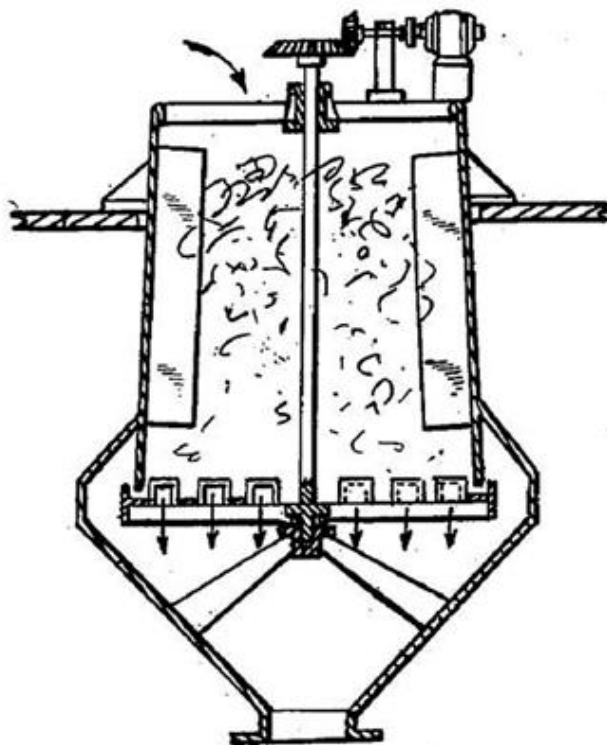

## References

### *Informative references*

*Attention is drawn to the following places, which may be of interest for search:*

Mechanical projectors for articles or solid materials, comprising discs, drums, or like rotary impellers	<a href="#">B65G 31/04</a>
Through which material passes	<a href="#">B65G 65/4872</a>

**B65G 65/4836**

{and moving material over a stationary surface, e.g. sweep arms or wheels}

**Definition statement**

*This place covers:*

Illustrative example of subject matter classified in this group:

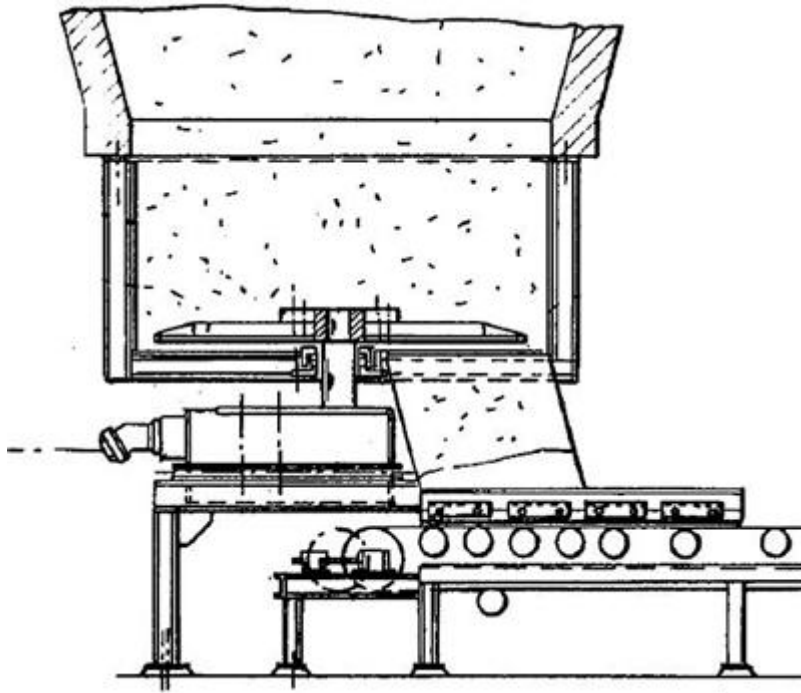
**References*****Informative references***

*Attention is drawn to the following places, which may be of interest for search:*

Through which material passes	<a href="#">B65G 65/4872</a>
-------------------------------	------------------------------

## B65G 65/4845

{flexible, e.g. chains, cables, spring arms}

### Definition statement

*This place covers:*

Illustrative examples of subject matter classified in this group:

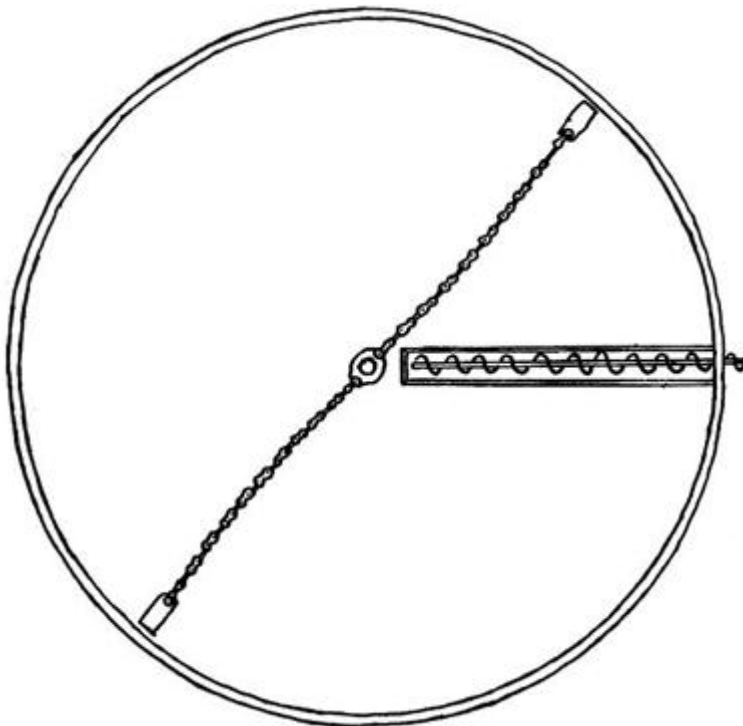
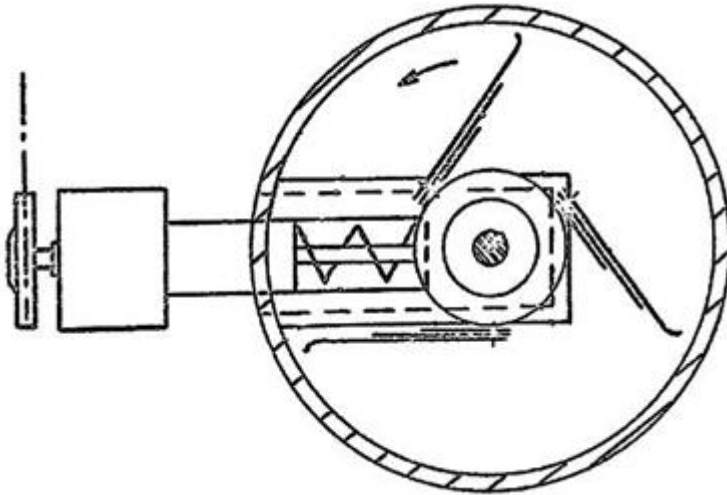



**B65G 65/4854**

{mounted on a carriage, e.g. for movement along slit-like outlets}

**Definition statement**

*This place covers:*

Illustrative examples of subject matter classified in this group:

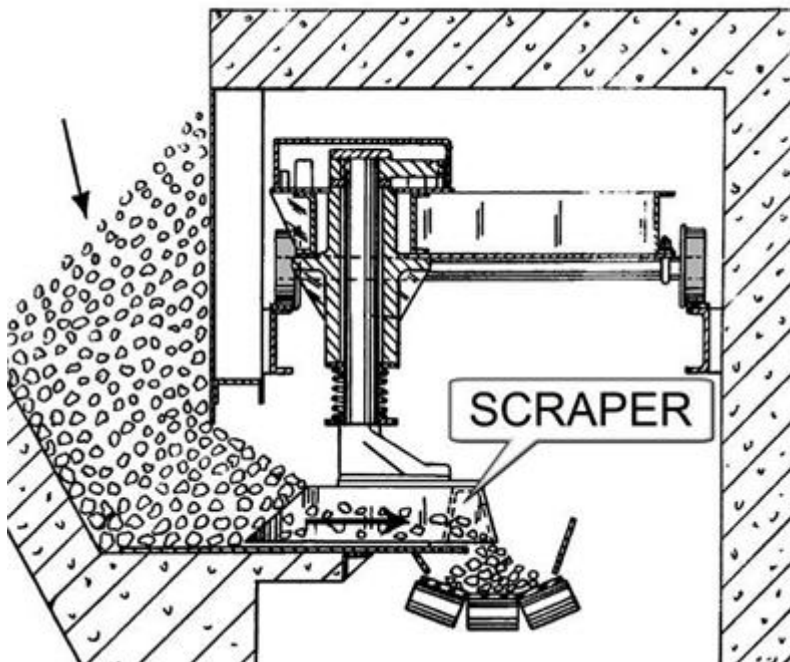
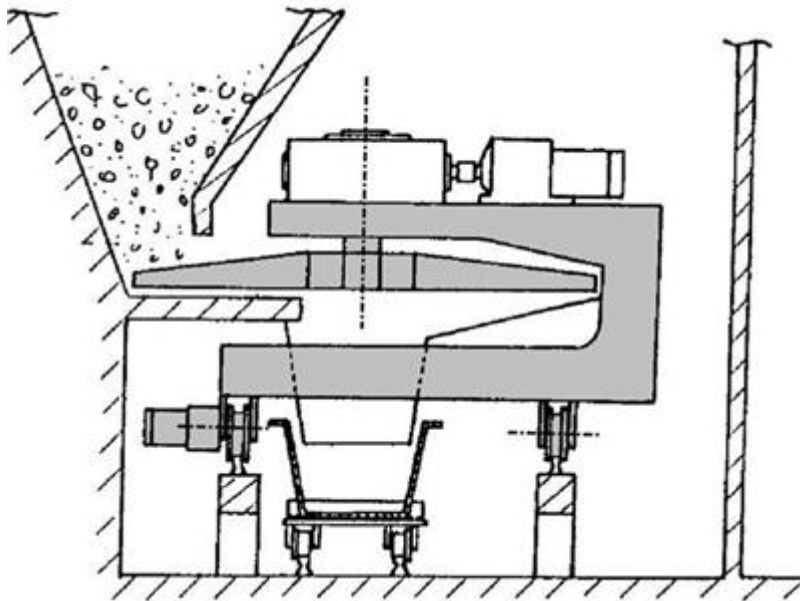
**References****Informative references**

Attention is drawn to the following places, which may be of interest for search:

Inclined surface, scrapers	<a href="#">B65G 65/44</a>
----------------------------	----------------------------

## B65G 65/4863

{by means of eccentric motion}

### Definition statement

*This place covers:*

Illustrative examples of subject matter classified in this group:

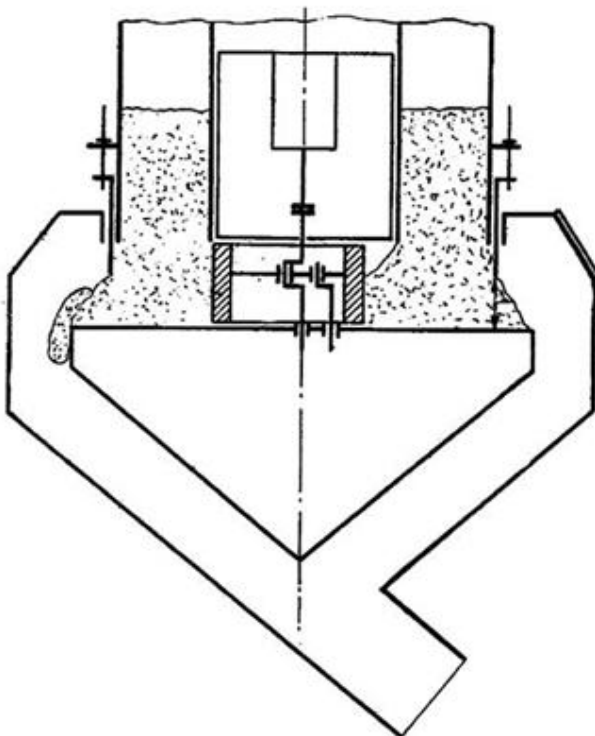
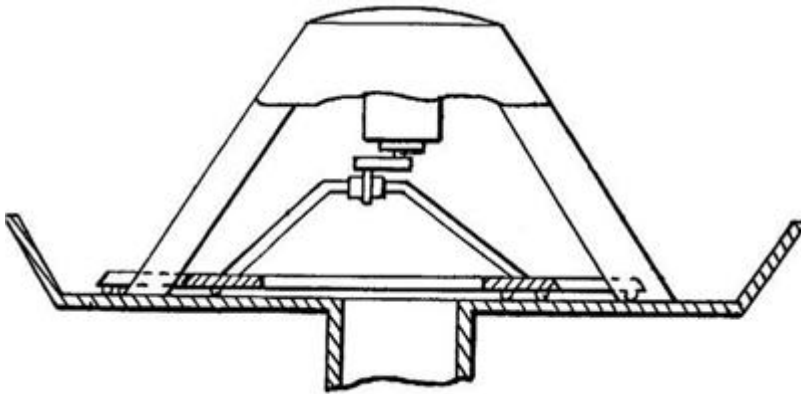

## B65G 65/4872

{through which material passes, e.g. fan-like wheels}

### Definition statement

*This place covers:*

Illustrative example of subject matter classified in this group:

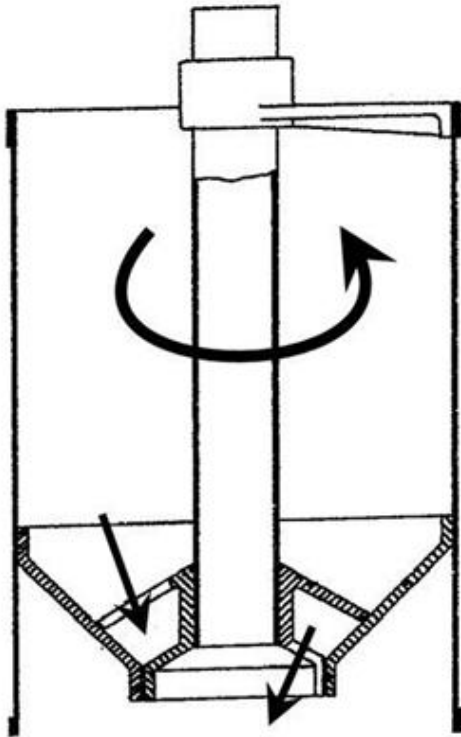

### References

#### Limiting references

*This place does not cover:*

When the material weight is on the rotating member	<a href="#">B65G 65/4827</a>
----------------------------------------------------	------------------------------

## B65G 65/4881

{rotating about a substantially horizontal axis}

### Definition statement

*This place covers:*

Illustrative examples of subject matter classified in this group:

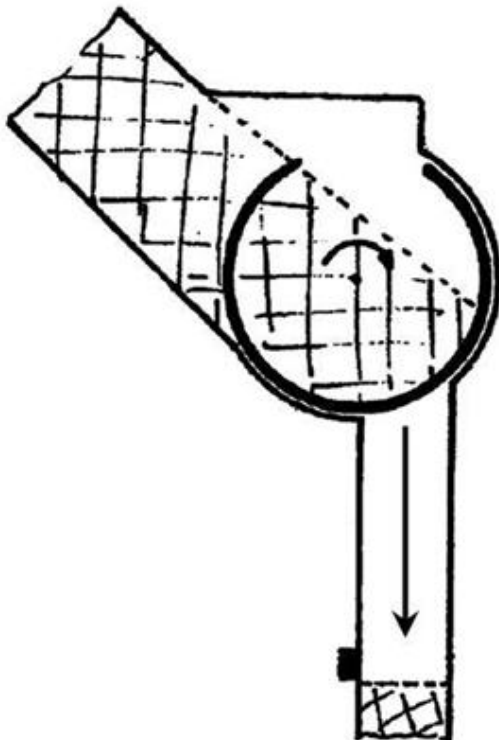
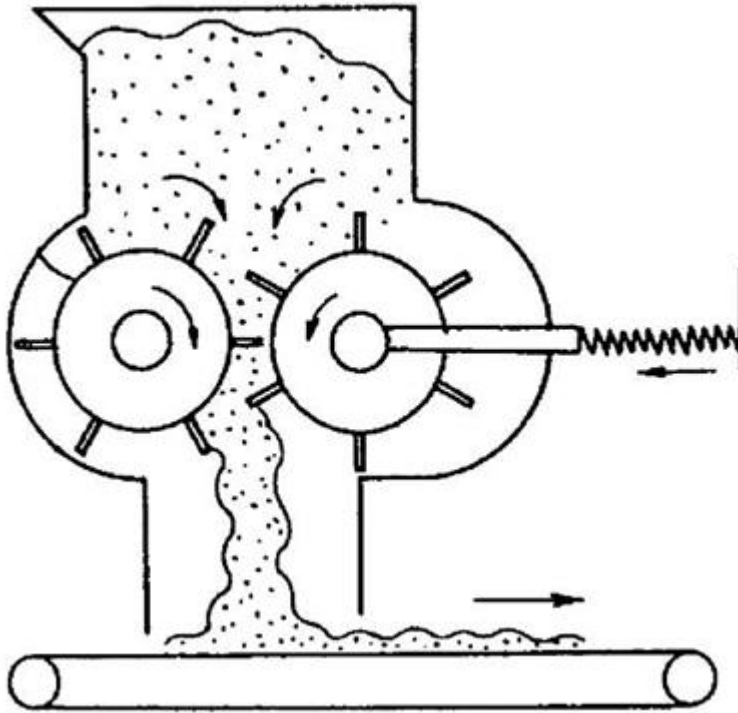

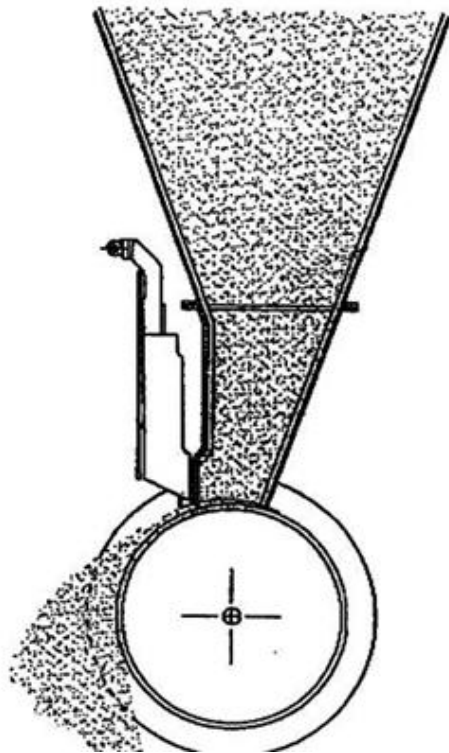

## References

### *Informative references*

*Attention is drawn to the following places, which may be of interest for search:*

With pneumatic conveyor	<a href="#">B65G 53/4633</a>
-------------------------	------------------------------

**B65G 65/489****{in the form of rotating tubular chutes}****Definition statement***This place covers:*

Illustrative example of subject matter classified in this group:

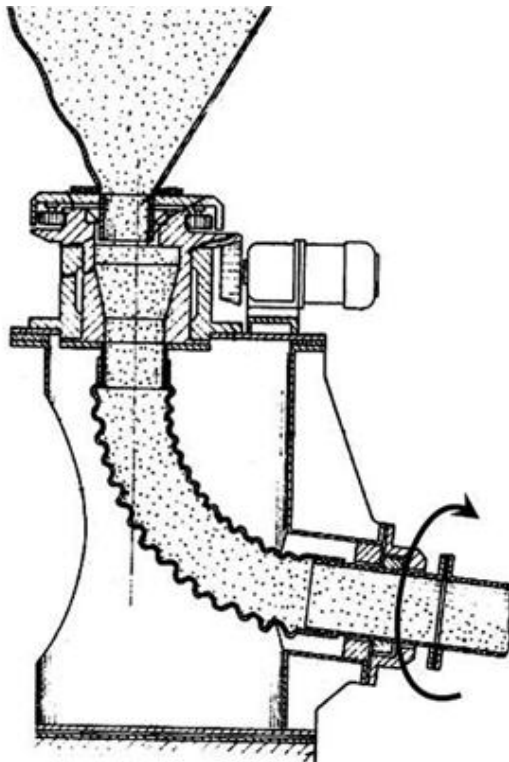
**B65G 67/00**

**Loading or unloading vehicles (by means incorporated in the vehicles [B60-B64](#), e.g., [B60P 1/00](#), [B61D 9/00](#), [B63B 27/00](#), [B64D 9/00](#); ground or aircraft-carrier-deck installations for aircraft [B64F 1/32](#))**

**References****Limiting references***This place does not cover:*

By means incorporated in the vehicles	<a href="#">B60 - B64</a>
Ground or aircraft-carrier-deck installations for aircraft	<a href="#">B64F 1/32</a>

**Application-oriented references**

*Examples of places where the subject matter of this place is covered when specially adapted, used for a particular purpose, or incorporated in a larger system:*

Transferring refuse between vehicles or containers	<a href="#">B65F 9/00</a>
----------------------------------------------------	---------------------------

**Informative references**

Attention is drawn to the following places, which may be of interest for search:

Other article loading or unloading devices	<a href="#">B65G 2814/0311</a>
With vertically reciprocating platforms	<a href="#">B65G 2814/0313</a>
Loading or unloading means	<a href="#">B65G 2814/0347</a> - <a href="#">B65G 2814/0395</a>
For ships	<a href="#">B65G 2814/0397</a>
For aircraft	<a href="#">B65G 2814/0398</a>

**B65G 67/02****Loading or unloading land vehicles****Definition statement**

*This place covers:*

Illustrative example of subject matter classified in this group:

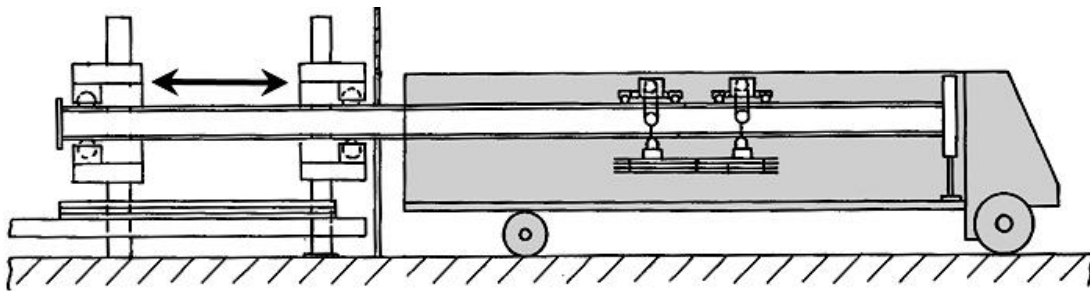

## B65G 67/04

Loading land vehicles {(loading or unloading boats to or from land vehicles [B60P 3/10](#))}

### Definition statement

*This place covers:*

Illustrative example of subject matter classified in this group:

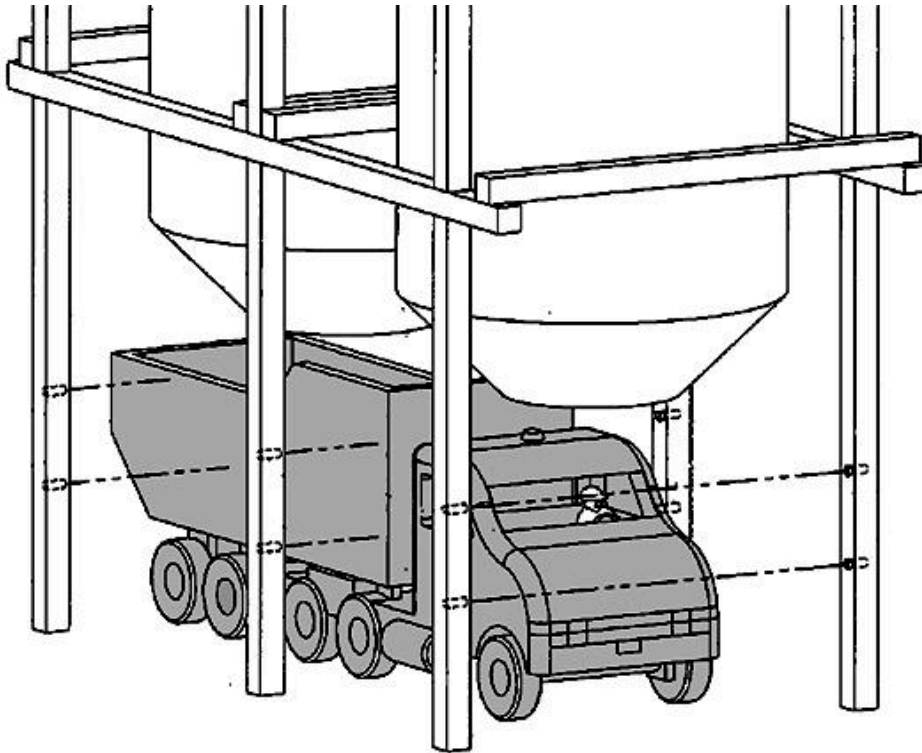

### References

#### *Informative references*

*Attention is drawn to the following places, which may be of interest for search:*

Optimal loading balance or loading pattern	<a href="#">G06Q 10/08</a>
--------------------------------------------	----------------------------



**B65G 67/06****Feeding articles or materials from bunkers or tunnels****Definition statement**

*This place covers:*

Illustrative example of subject matter classified in this group:

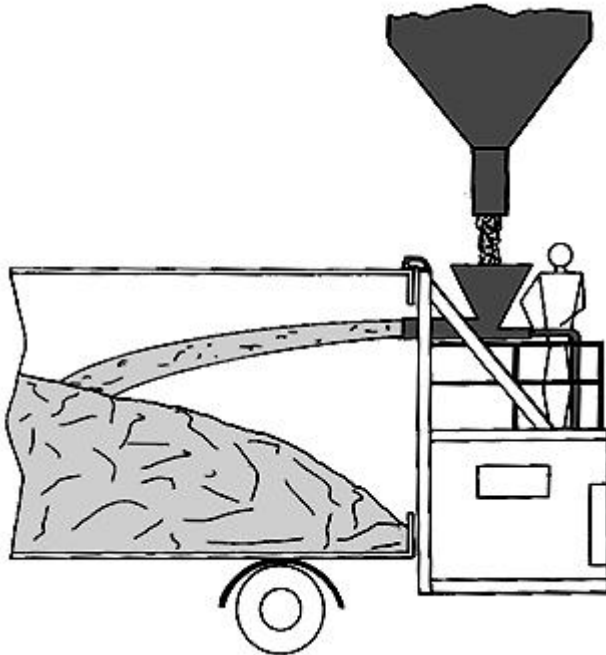
**B65G 67/08****using endless conveyors****Definition statement**

*This place covers:*

Illustrative example of subject matter classified in this group:

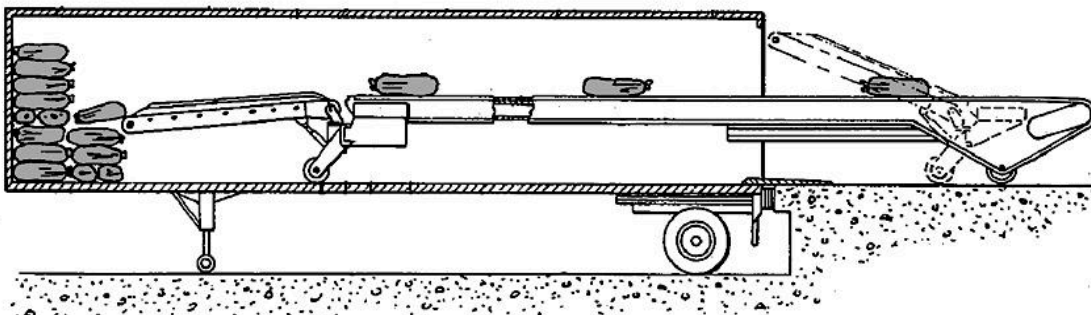
**References****Informative references**

Attention is drawn to the following places, which may be of interest for search:

Telescopic	<a href="#">B65G 21/14</a>
------------	----------------------------

For airplanes

[B64F 1/32](#)

## B65G 67/10

using conveyors covering the whole length of vehicle trains

### Definition statement

*This place covers:*

Illustrative example of subject matter classified in this group:

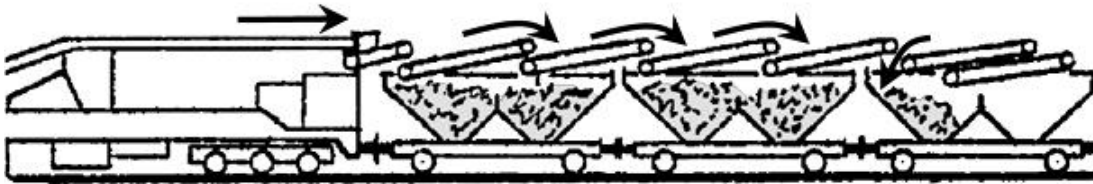

## B65G 67/12

Loading elongated articles, e.g. rails, logs

### Definition statement

*This place covers:*

Illustrative example of subject matter classified in this group:

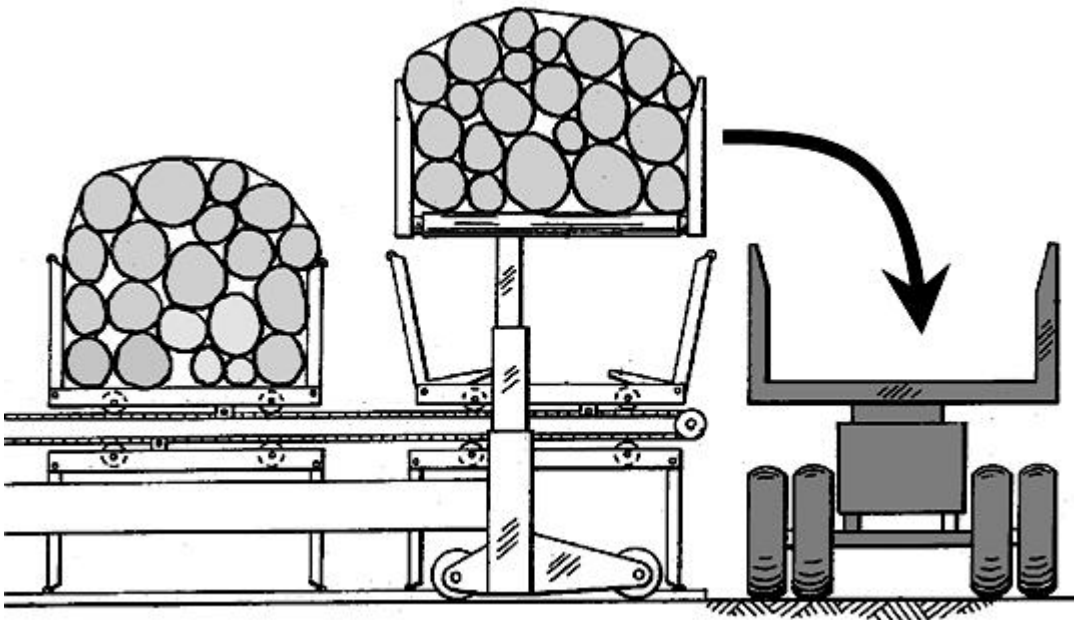

### Special rules of classification

Indexing Code: [B65G 2201/0217](#)

**B65G 67/14****Loading hardened bricks, briquettes, or the like****Definition statement**

*This place covers:*

Illustrative example of subject matter classified in this group:

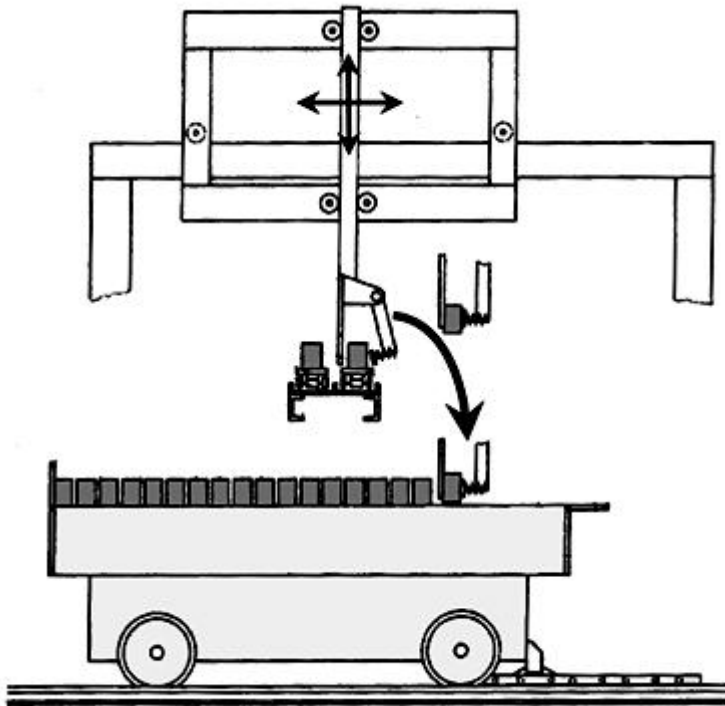
**References****Informative references**

*Attention is drawn to the following places, which may be of interest for search:*

For ceramic mouldings	<a href="#">B65G 49/08</a>
-----------------------	----------------------------

**B65G 67/16****Loading coke-oven products (discharging coke-ovens [C10B 33/00](#))****References****Informative references**

*Attention is drawn to the following places, which may be of interest for search:*

Skip loading	<a href="#">B66B 17/26</a>
--------------	----------------------------

## B65G 67/18

### Refuelling locomotives with solid fuels

#### References

##### *Informative references*

*Attention is drawn to the following places, which may be of interest for search:*

Servicing locomotives	<a href="#">B61K 11/02</a>
Skip loading	<a href="#">B66B 17/26</a>

## B65G 67/20

### Loading covered vehicles

#### Definition statement

*This place covers:*

Illustrative examples of subject matter classified in this group:

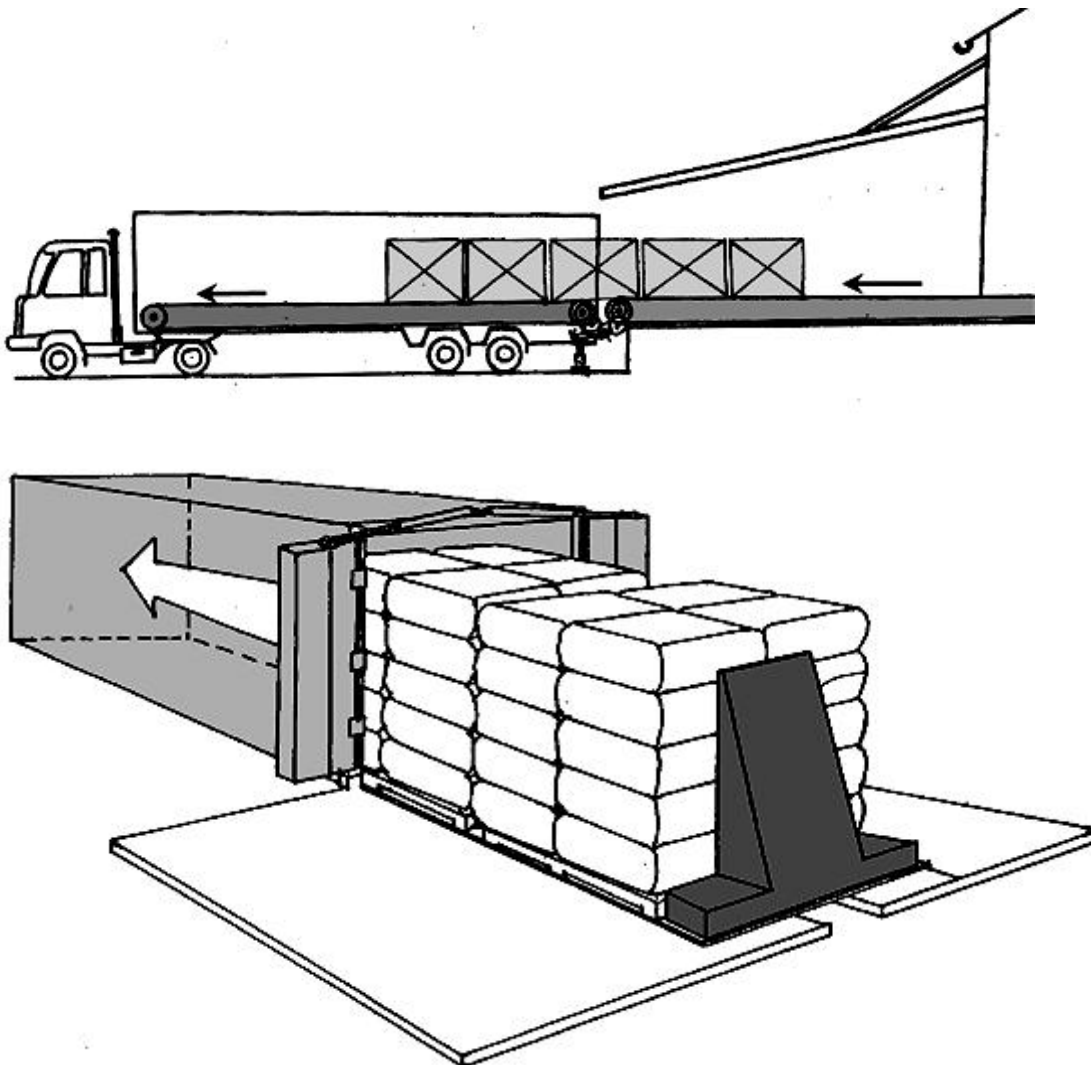

## References

### Informative references

Attention is drawn to the following places, which may be of interest for search:

Rollerways with inflatable lifting means	<a href="#">B65G 13/12</a>
Equipment for handling freight	<a href="#">B64D 9/00</a>

## B65G 67/22

### Loading moving vehicles

#### Definition statement

This place covers:

Illustrative examples of subject matter classified in this group:

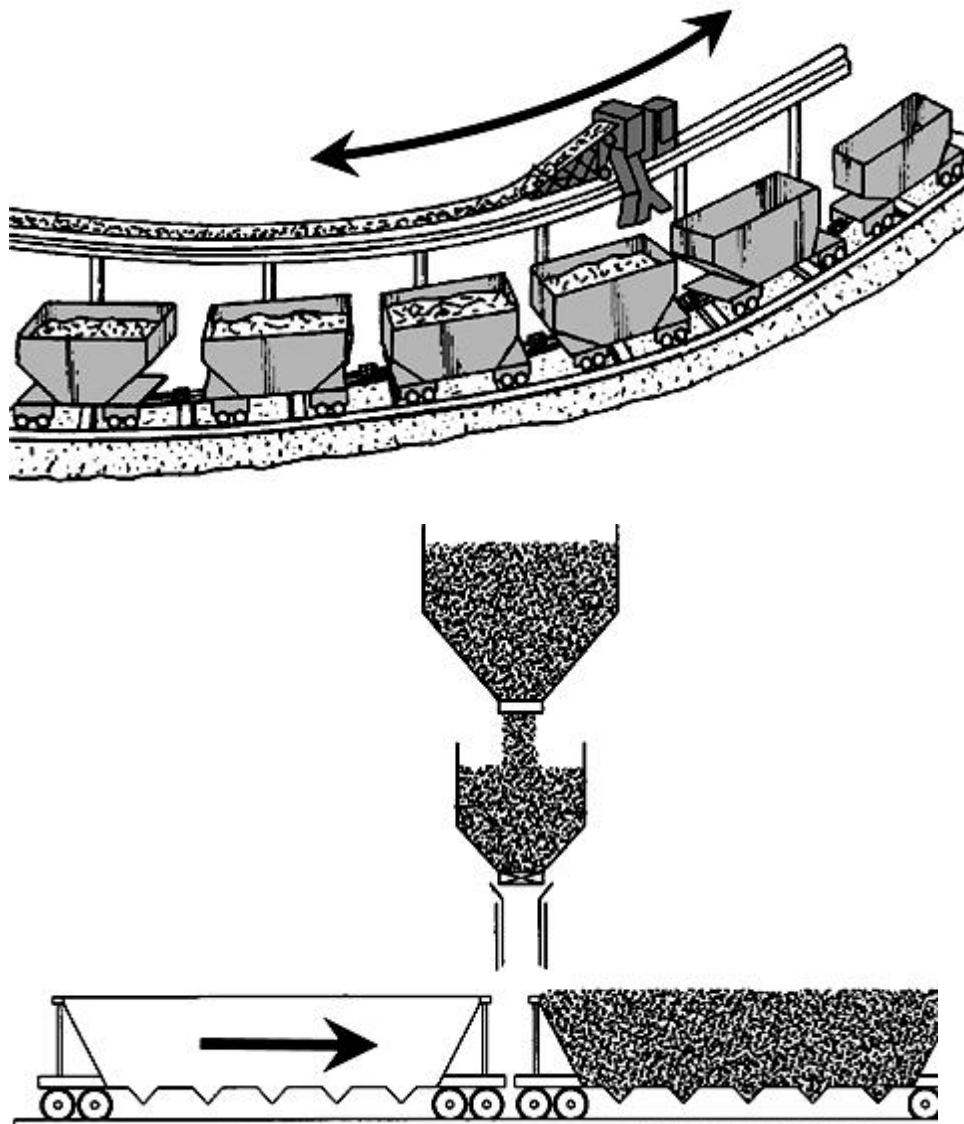

**References**

**Informative references**

Attention is drawn to the following places, which may be of interest for search:

Using conveyors covering the whole length of vehicle trains	<a href="#">B65G 67/10</a>
Spreading out the materials conveyed by relatively moving an endless feeding means	<a href="#">B65G 69/0408</a>

**B65G 67/24**

**Unloading land vehicles**

**Definition statement**

This place covers:

Illustrative example of subject matter classified in this group:

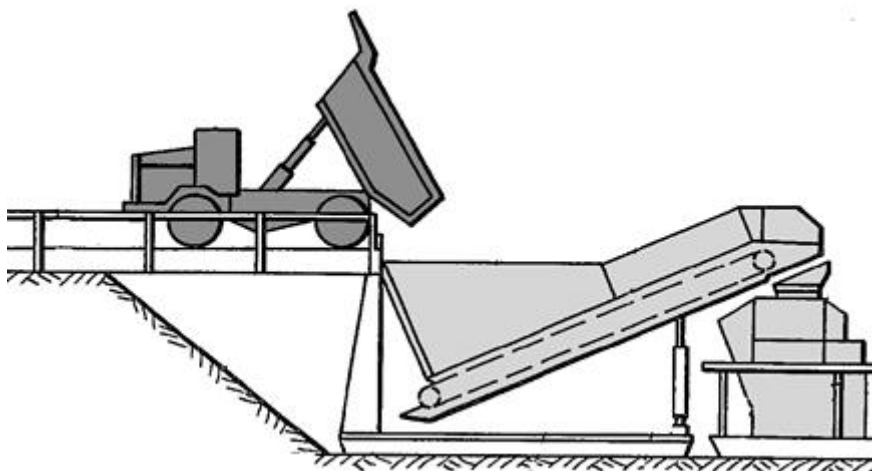
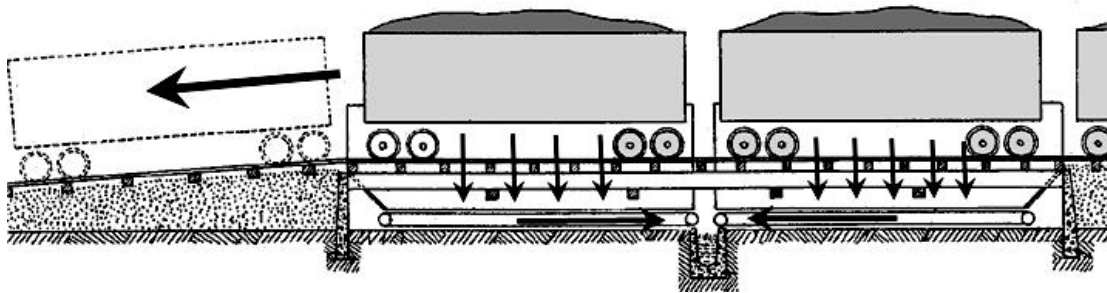

**References**

**Informative references**

Attention is drawn to the following places, which may be of interest for search:

Controlled unloading	<a href="#">B65G 47/19</a>
Loading covered vehicles	<a href="#">B65G 67/20</a>



## B65G 67/26

using rakes or scrapers

### Definition statement

*This place covers:*

Illustrative example of subject matter classified in this group:

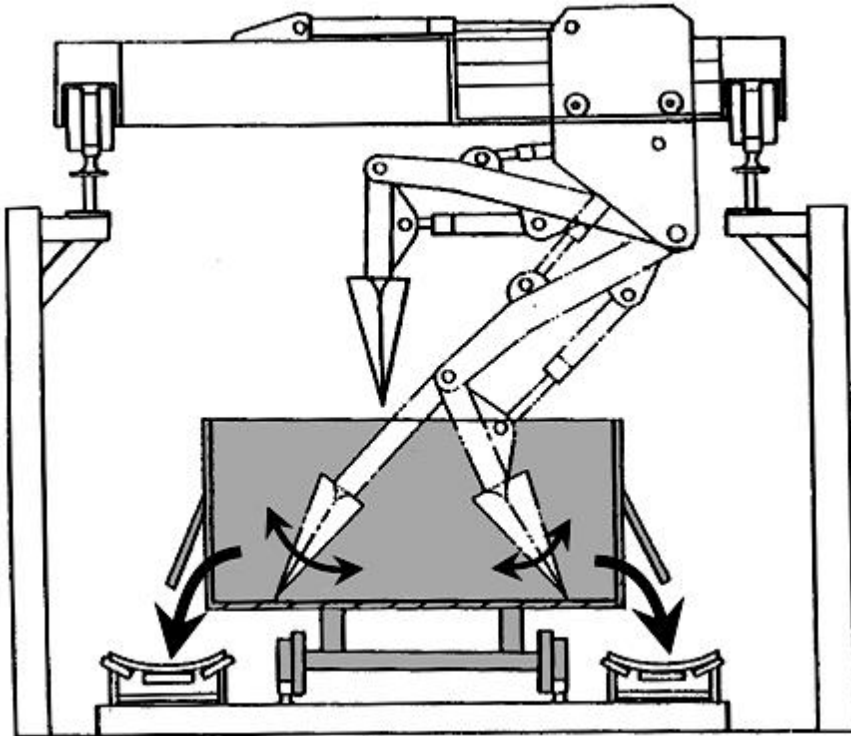

**B65G 67/28****External transverse blades attached to endless conveyors****Definition statement**

*This place covers:*

Illustrative example of subject matter classified in this group:

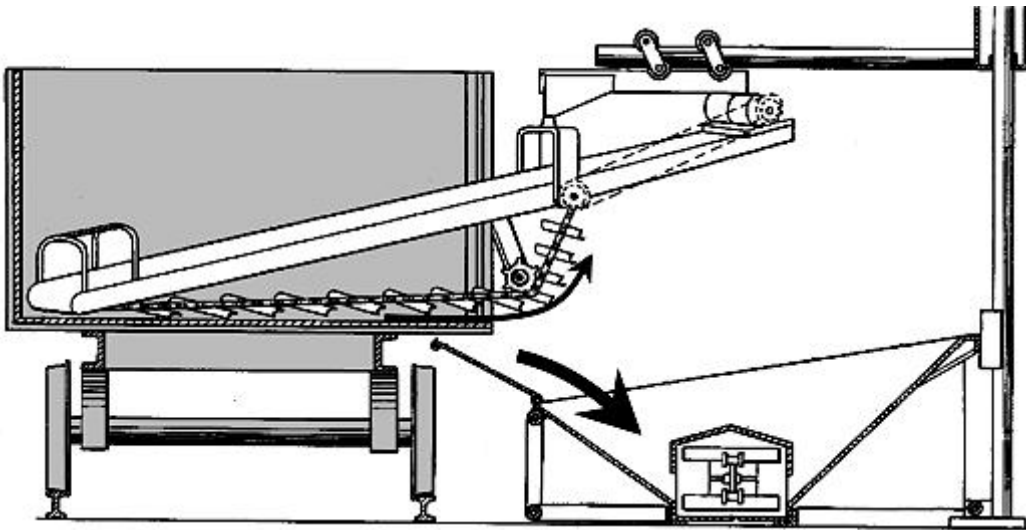
**B65G 67/30****using transportable tipping apparatus****Definition statement**

*This place covers:*

Illustrative example of subject matter classified in this group:

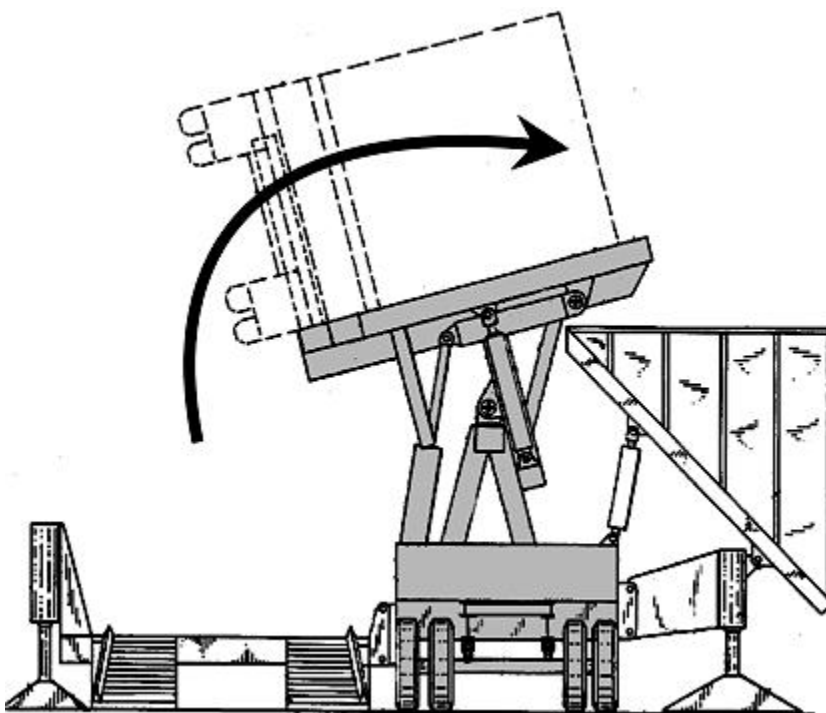



**Special rules of classification**

For [B65G 67/30-B65G 67/56](#) see Indexing Codes [B65G 2814/0356](#) - [B65G 2814/0395](#).

**B65G 67/32**

using fixed tipping installations

**Definition statement**

*This place covers:*

Illustrative example of subject matter classified in this group:

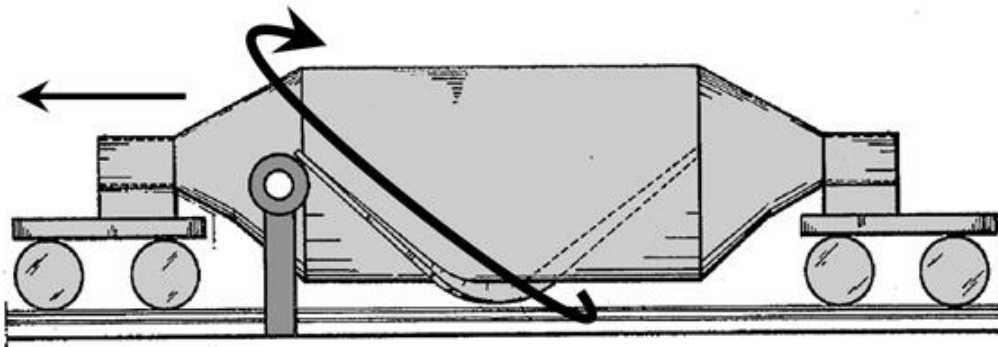
**B65G 67/34**

Apparatus for tipping wagons or mine cars (inverting wagons [B65G 67/48](#))

**References****Limiting references**

*This place does not cover:*

Inverting wagons	<a href="#">B65G 67/48</a>
------------------	----------------------------

**Informative references**

*Attention is drawn to the following places, which may be of interest for search:*

Platform-lifts with tiltable platforms	<a href="#">B66F 7/22</a>
----------------------------------------	---------------------------

**B65G 67/36**

endwise

**Definition statement**

*This place covers:*

Towards both ends (otherwise [B65G 67/40](#))

Illustrative example of subject matter classified in this group:

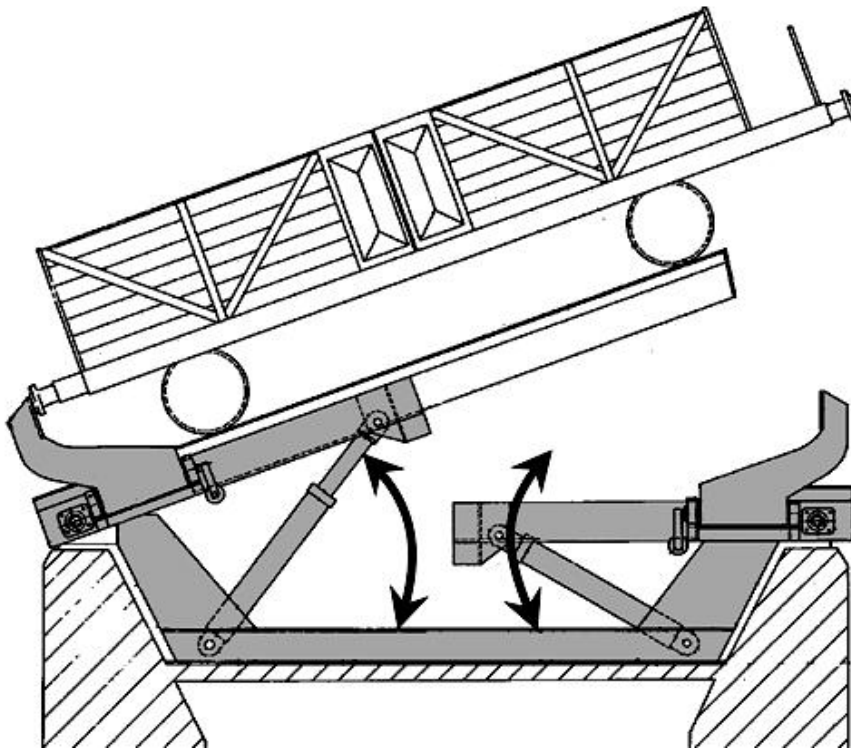

**B65G 67/40**

toward one end only

**Definition statement**

*This place covers:*

Illustrative example of subject matter classified in this group:

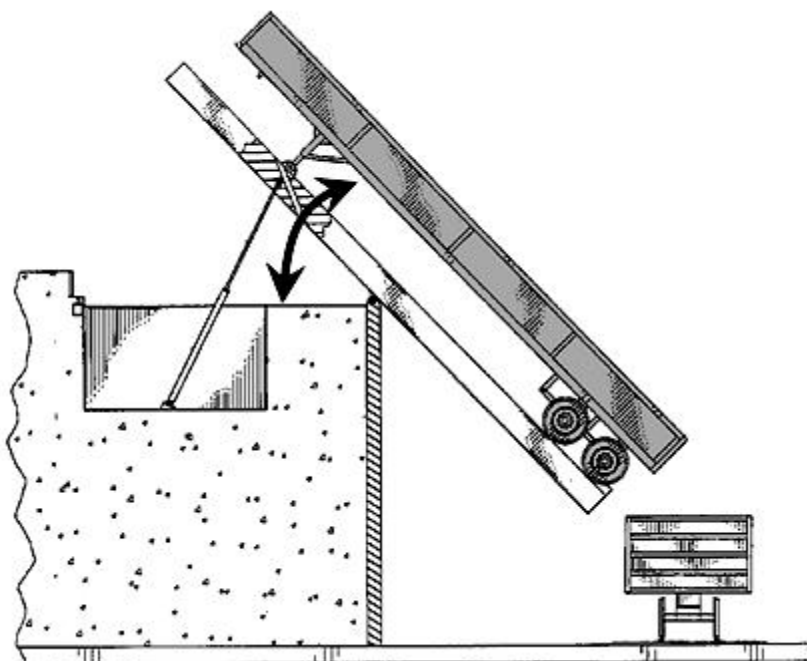

**References**

**Informative references**

Attention is drawn to the following places, which may be of interest for search:

Endwise	<a href="#">B65G 67/36</a>
---------	----------------------------

**B65G 67/42**

**sideways**

**Definition statement**

*This place covers:*

Illustrative example of subject matter classified in this group:

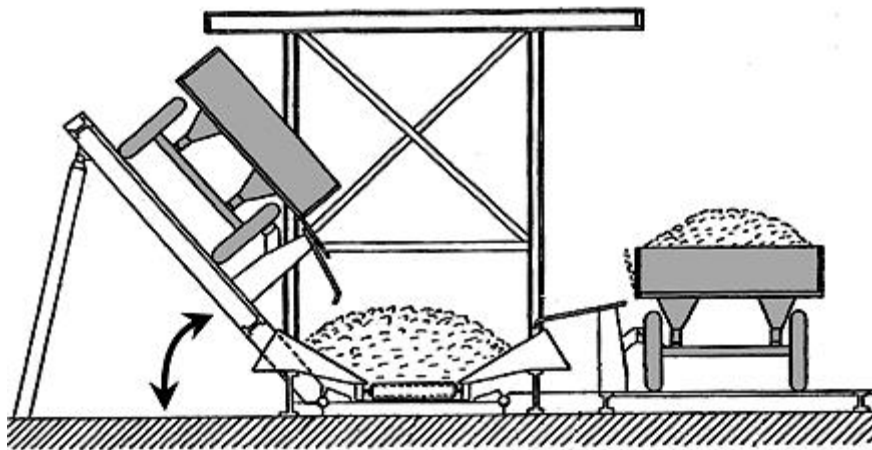

**References**

**Limiting references**

*This place does not cover:*

Lifting and tipping	<a href="#">B65G 67/46</a>
Rotating 360°	<a href="#">B65G 67/50</a>

## B65G 67/44

by passing the vehicles over a stretch of transversely-inclined rails

### Definition statement

*This place covers:*

Illustrative example of subject matter classified in this group:

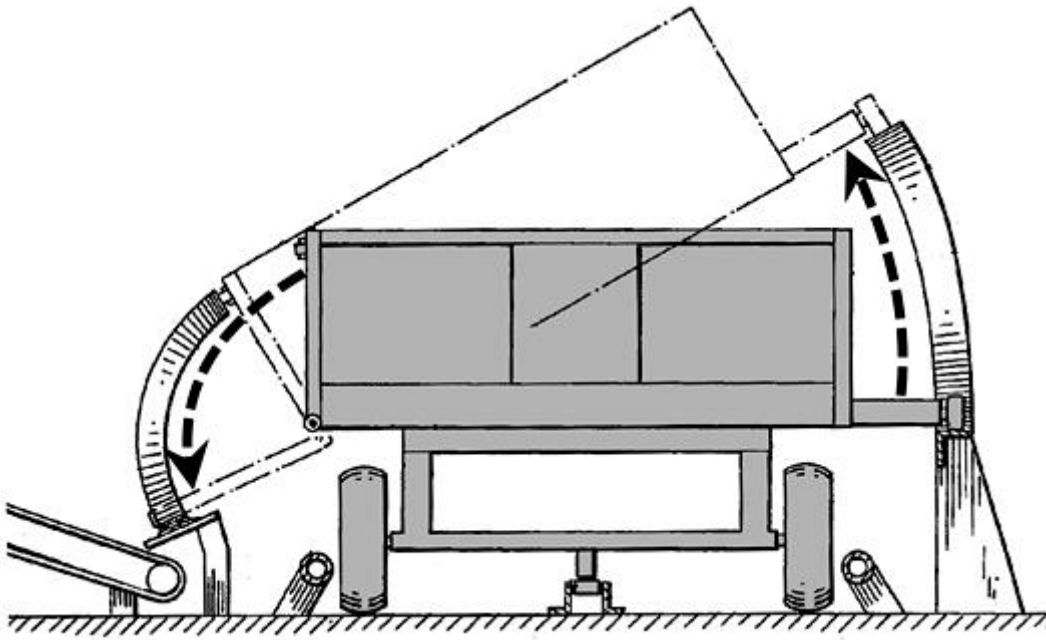

**B65G 67/46****Apparatus for lifting and tilting****Definition statement**

*This place covers:*

Illustrative example of subject matter classified in this group:

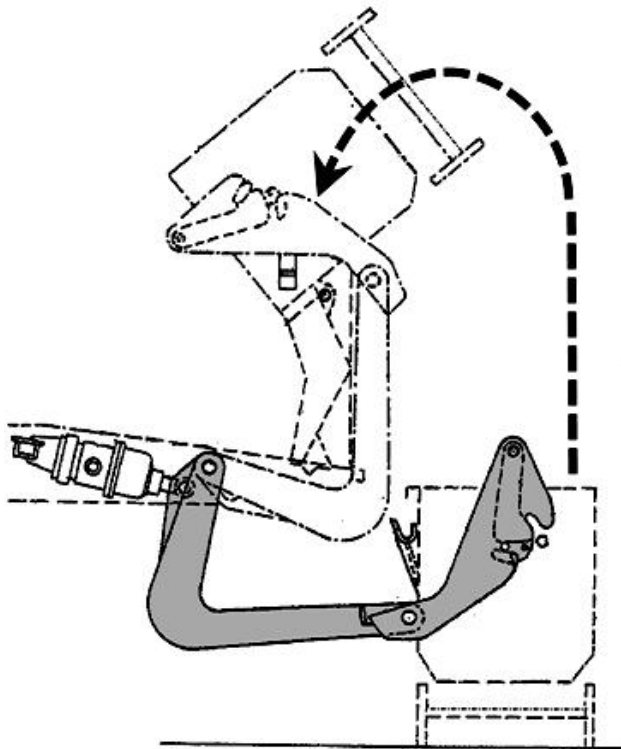
**B65G 67/48****Vehicle tipplers****References****Informative references**

*Attention is drawn to the following places, which may be of interest for search:*

Devices for washing or cleaning railroad vehicles	<a href="#">B60S</a>
---------------------------------------------------	----------------------

**B65G 67/50****Rotary vehicle tipplers, i.e. rotating through 360 degrees****Definition statement**

*This place covers:*

Rotation about one axis (ring-construction ostly)

Illustrative example of subject matter classified in this group:

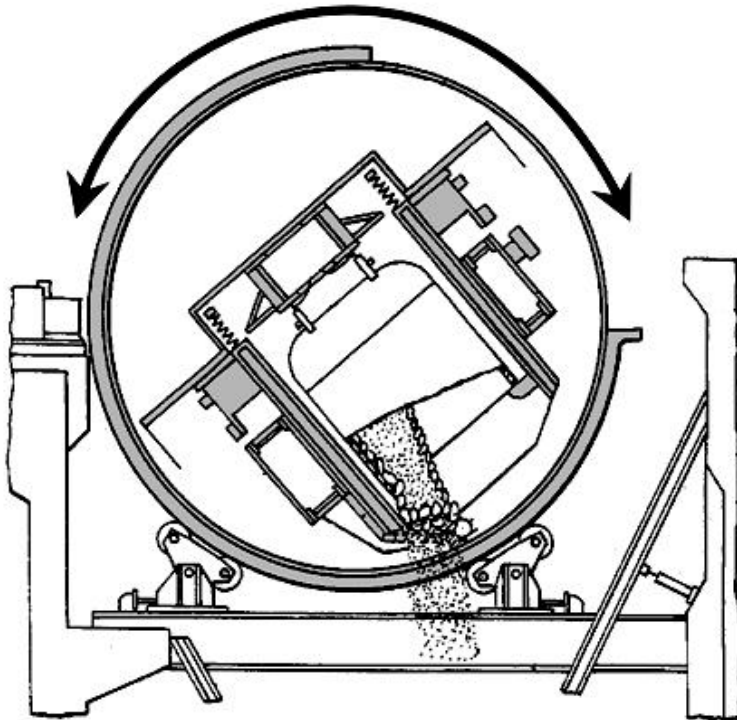

## References

### *Informative references*

*Attention is drawn to the following places, which may be of interest for search:*

Vehicle-locking means	<a href="#">B65G 67/54</a>
Vehicle and tippler interlocking controls	<a href="#">B65G 67/56</a>

## **B65G 67/52**

**having several decks**

### **Definition statement**

*This place covers:*

Illustrative example of subject matter classified in this group:

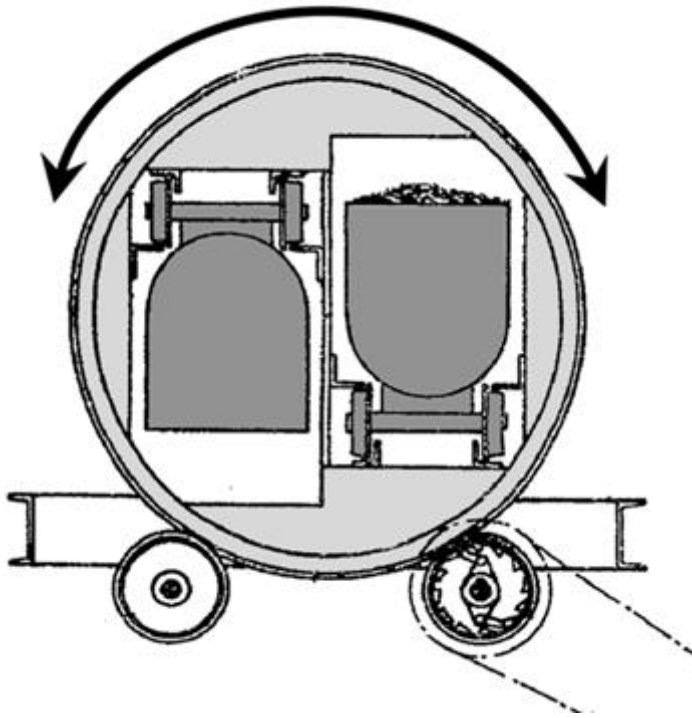

## B65G 67/54

### Vehicle-locking means

#### Definition statement

*This place covers:*

Illustrative example of subject matter classified in this group:

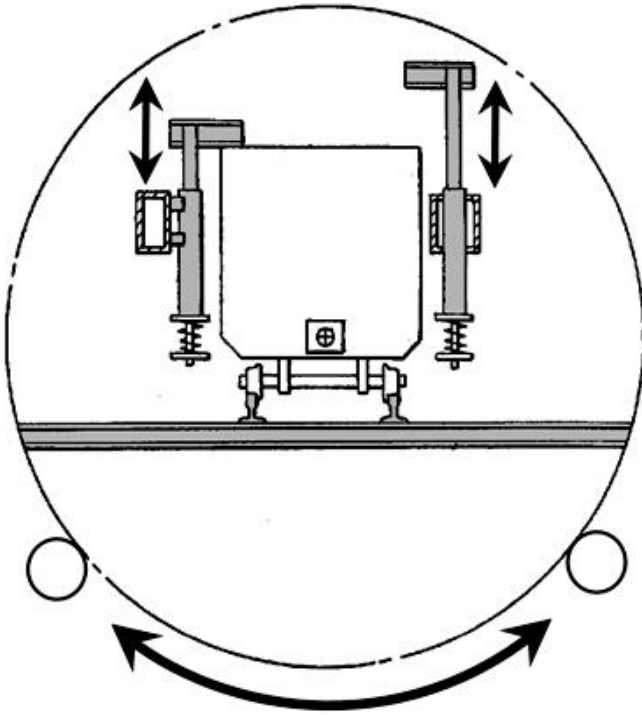



## B65G 67/56

### Vehicle and tippler interlocking controls

#### Definition statement

*This place covers:*

Illustrative example of subject matter classified in this group:

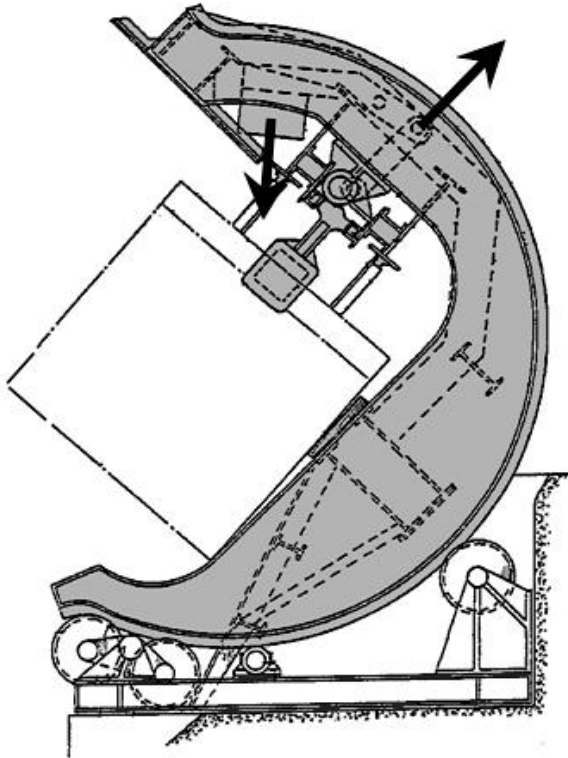

#### Special rules of classification

Indexing Code: [B65G 2814/0362](#)

**B65G 67/603****{using devices specially adapted for articles}****Definition statement***This place covers:*

Illustrative example of subject matter classified in this group:

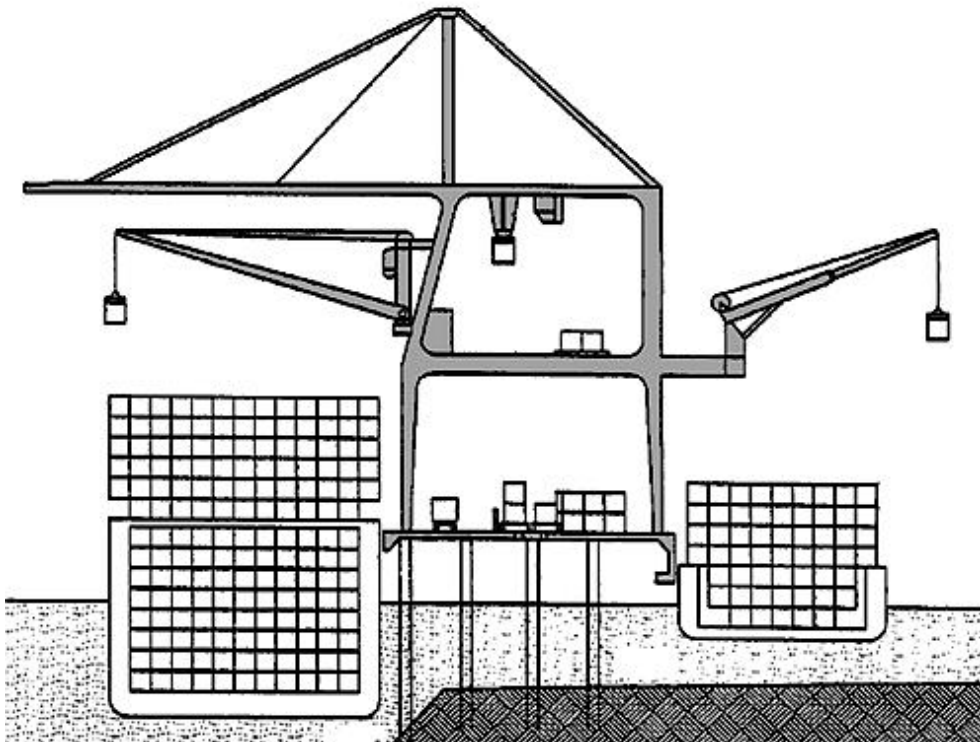
**References****Informative references***Attention is drawn to the following places, which may be of interest for search:*

Transferring or trans-shipping at storage areas, railway yards, harbours; Marshalling yard installations	<a href="#">B65G 63/00</a>
-------------------------------------------------------------------------------------------------------------	----------------------------

**B65G 67/606**

{using devices specially adapted for bulk material}

**Definition statement**

*This place covers:*

Illustrative example of subject matter classified in this group:

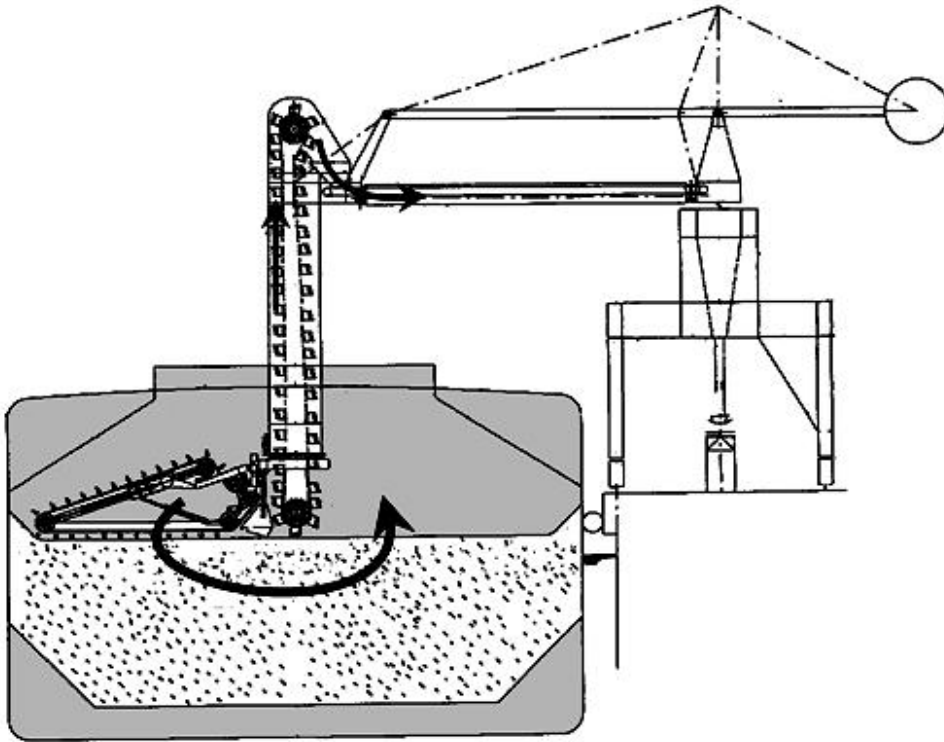
**References****Informative references**

*Attention is drawn to the following places, which may be of interest for search:*

Bucket conveyors	<a href="#">B65G 17/126</a>
Endless scraping or elevating pick-up conveyors	<a href="#">B65G 65/06</a>

## B65G 67/62

using devices influenced by the tide or by the movements of the ship, e.g. devices on pontoons

### Definition statement

*This place covers:*

Illustrative example of subject matter classified in this group:

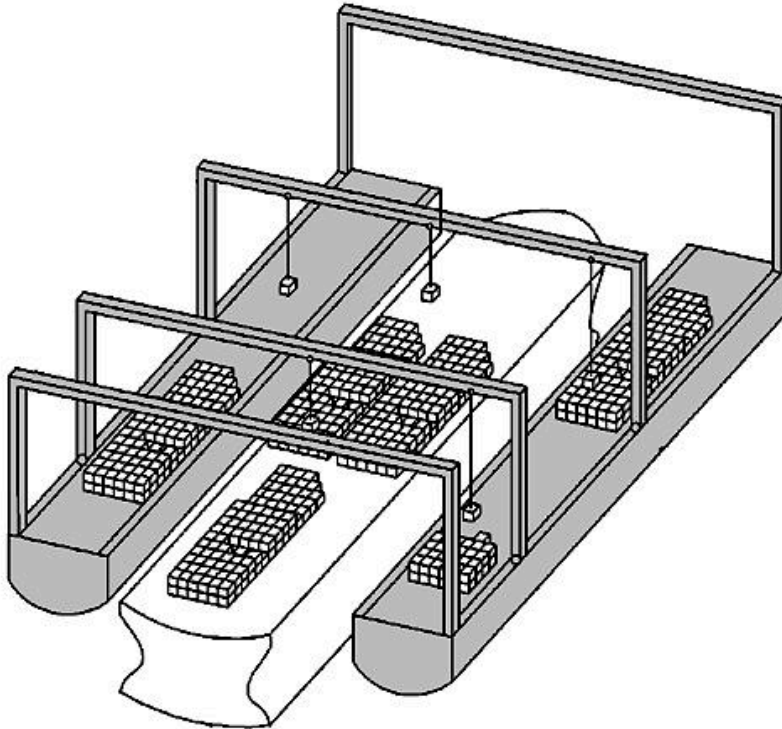

### References

#### *Informative references*

*Attention is drawn to the following places, which may be of interest for search:*

Horizontal loading or unloading platforms	<a href="#">B65G 69/22</a>
Loading ramps	<a href="#">B65G 69/28</a>

## B65G 69/00

Auxiliary measures taken, or devices used, in connection with loading or unloading (by means incorporated in, or operatively associated with, conveyors [B65G 47/00](#); preventing fire [A62C 3/00](#); in vehicles, see the relevant subclasses, e.g., [B60P 1/58](#), [B61D 7/32](#), [B62D 33/00](#), [B63B 25/00](#), [B64D 9/00](#))

### References

#### Limiting references

*This place does not cover:*

By means incorporated in, or operatively associated with, conveyors	<a href="#">B65G 47/00</a>
Preventing fire	<a href="#">A62C 3/00</a>
In vehicles	<a href="#">B60P 1/58</a> , <a href="#">B61D 7/32</a> , <a href="#">B62D 33/00</a> , <a href="#">B63B 25/00</a> , <a href="#">B64D 9/00</a>

#### Informative references

*Attention is drawn to the following places, which may be of interest for search:*

Indexing Codes relating to loading or unloading articles or bulk materials	<a href="#">B65G 2814/00</a> - <a href="#">B65G 2814/0211</a>
For spreading out the material over the whole surface to be loaded	<a href="#">B65G 2814/0241</a> - <a href="#">B65G 2814/0294</a>
The walls being deformable	<a href="#">B65D 88/62</a>

**B65G 69/001****{Buffers for vehicles at loading stations}****Definition statement***This place covers:*

Illustrative example of subject matter classified in this group:

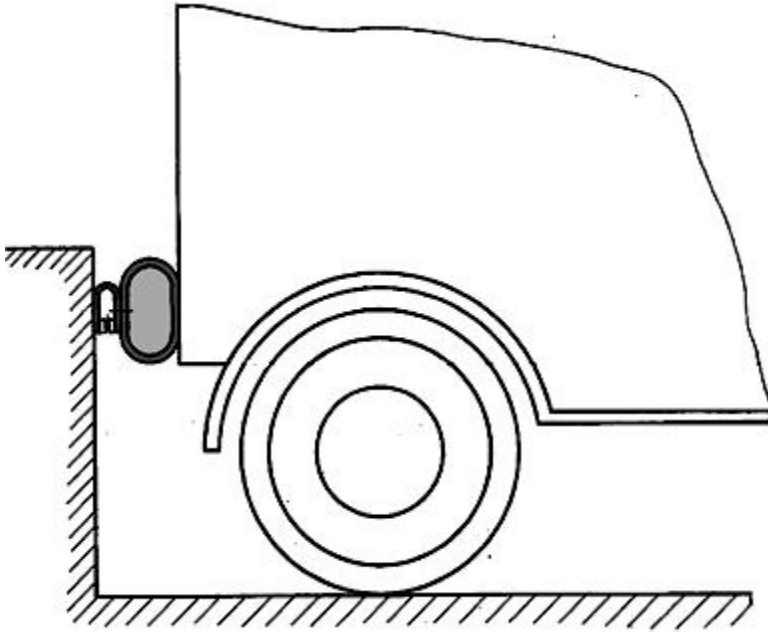
**References****Informative references***Attention is drawn to the following places, which may be of interest for search:*

For racks	<a href="#">B65G 1/02</a>
Safety arrangements for slowing, redirecting or stopping errant vehicles; local protection	<a href="#">E01F 15/14</a>
Fenders; fenders integral with waterborne vessels or specially adapted therefor	<a href="#">E02B 3/26</a>

**Special rules of classification**IPC: **B65G69/34**

## B65G 69/003

{Restraining movement of a vehicle at a loading station using means not being part of the vehicle}

### Definition statement

*This place covers:*

Illustrative example of subject matter classified in this group:

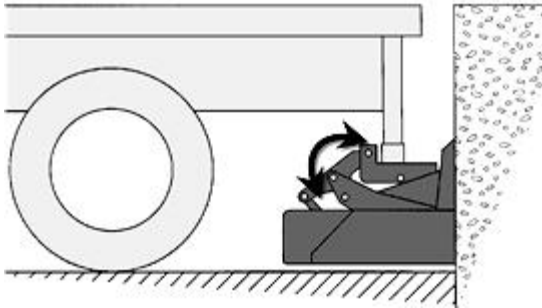

### Special rules of classification

IPC: **B65G69/34**

## B65G 69/005

{the means engaging at least one wheel of the vehicle}

### Definition statement

*This place covers:*

Illustrative example of subject matter classified in this group:

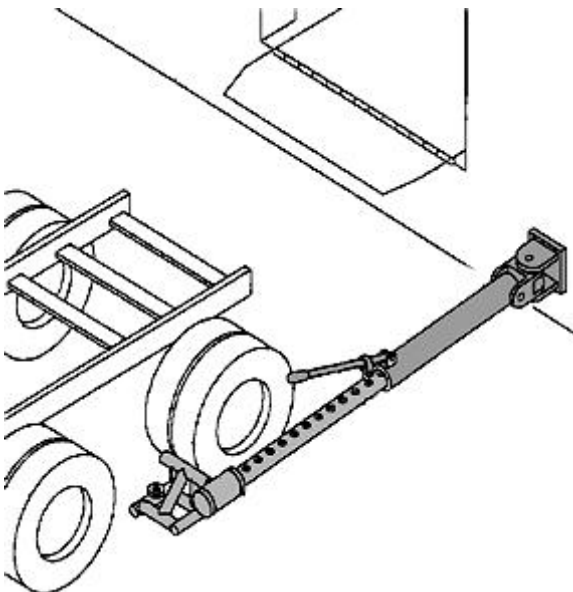

## References

### Informative references

Attention is drawn to the following places, which may be of interest for search:

Electric devices on electrically-propelled vehicles for safety purposes; Monitoring operating variables	<a href="#">B60L 3/00</a>
Securing of load by preventing lateral movement of the load	<a href="#">B60P 7/0892</a>
Wheel chocks	<a href="#">B60T 3/00</a>

## Special rules of classification

IPC: **B65G69/34**

### B65G 69/006

{Centring or aligning a vehicle at a loading station using means not being part of the vehicle}

### Definition statement

*This place covers:*

Illustrative example of subject matter classified in this group:

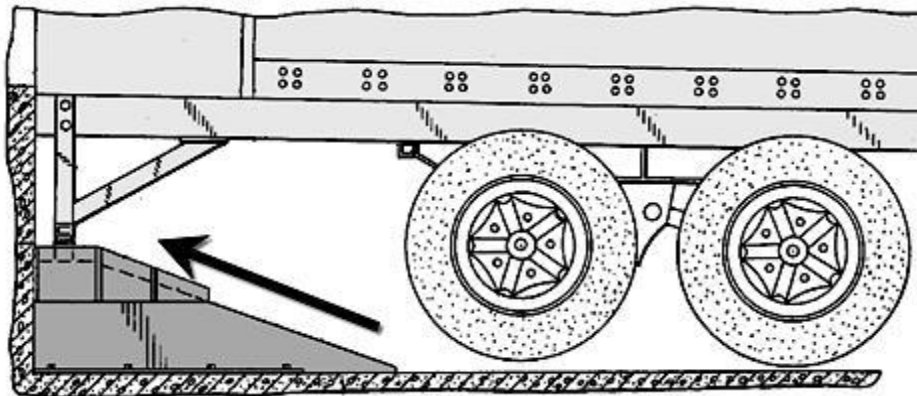

## Special rules of classification

IPC: **B65G69/34**



## **B65G 69/008**

**{Dock- or bumper-seals}**

### **Definition statement**

*This place covers:*

Illustrative example of subject matter classified in this group:

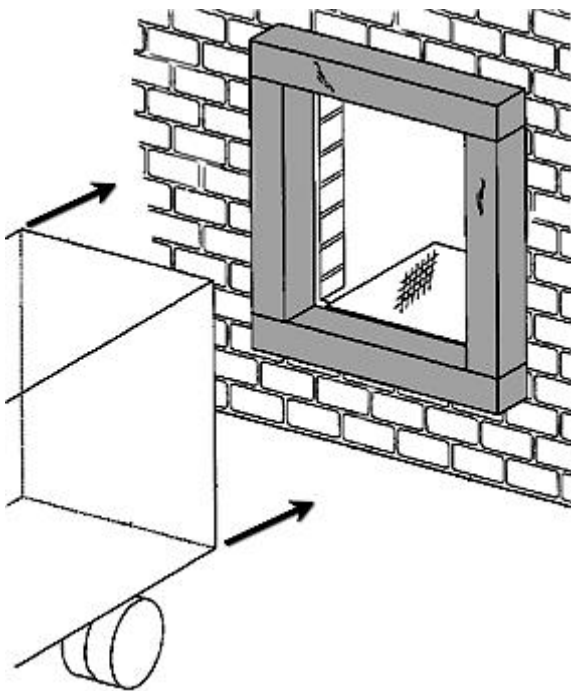

### **Special rules of classification**

IPC: **B65G69/34**

## **B65G 69/02**

**Filling storage spaces as completely as possible, e.g. application of vibrators**

### **Definition statement**

*This place covers:*

Only when the material is already in the container

Mainly: densifying/vibrators

Illustrative example of subject matter classified in this group:

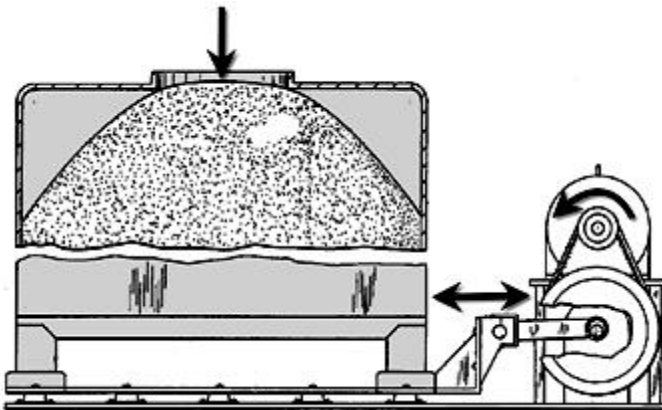

**References**

**Limiting references**

*This place does not cover:*

Spreading out the materials conveyed over the whole surface to be loaded; Trimming heaps of loose materials	<a href="#">B65G 69/04</a>
Densifying using the feeding conveyor	<a href="#">B65G 69/20</a>

**B65G 69/04**

**Spreading out the materials conveyed over the whole surface to be loaded;  
 Trimming heaps of loose materials**

**Definition statement**

*This place covers:*

Illustrative example of subject matter classified in this group:

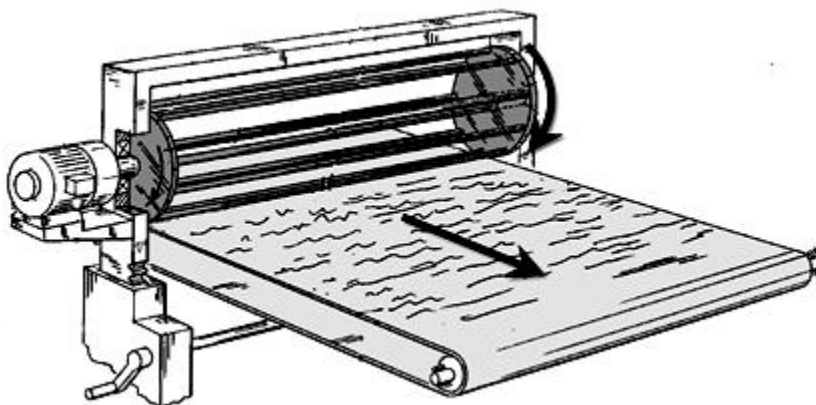

**References**

**Informative references**

*Attention is drawn to the following places, which may be of interest for search:*

Having means for controlling material flow	<a href="#">B65G 47/19</a>
For a homogeneous pile	<a href="#">B65G 69/10</a>

Distributing or orienting the particles or fibres	<a href="#">B27N 3/14</a>
---------------------------------------------------	---------------------------

## B65G 69/0408

{by relatively moving an endless feeding means ([B65G 69/0458](#) takes precedence)}

### Definition statement

*This place covers:*

Illustrative example of subject matter classified in this group:

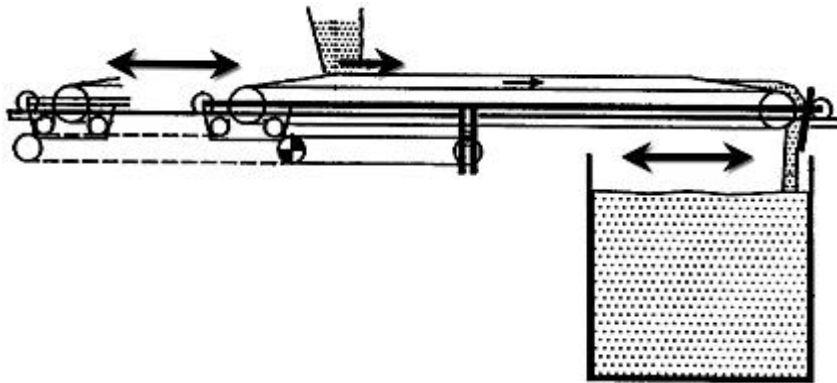

### References

#### Limiting references

*This place does not cover:*

With rotating means	<a href="#">B65G 69/0458</a>
The discharge point is moving over the loaded surface	

**B65G 69/0416****{with scraping belts or chains}****Definition statement***This place covers:*

Illustrative example of subject matter classified in this group:

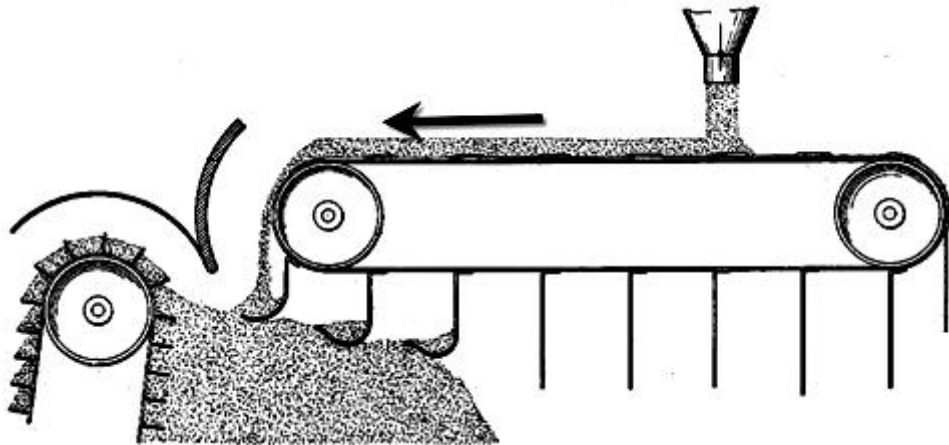
**B65G 69/0425****{with vibrating or shaking means}****Definition statement***This place covers:*

Illustrative example of subject matter classified in this group:

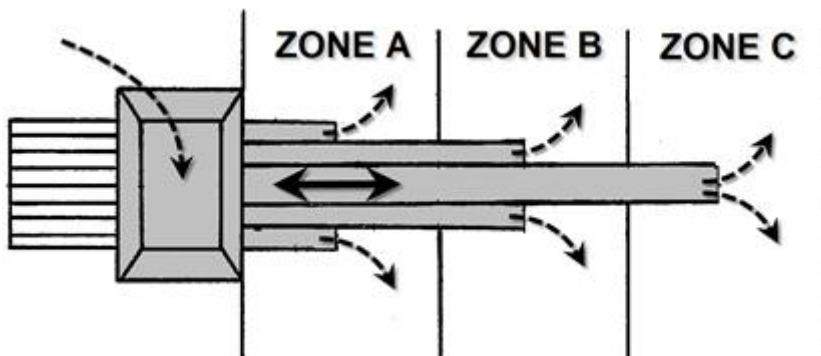

## B65G 69/0433

{with screw conveyors}

### Definition statement

*This place covers:*

Illustrative example of subject matter classified in this group:

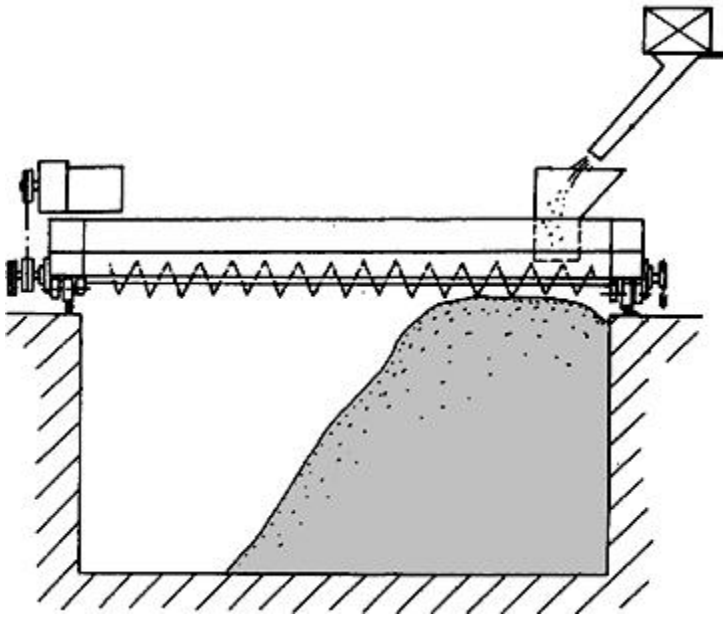

## B65G 69/0441

{with chutes, deflector means or channels ([B65G 69/0458](#) takes precedence)}

### Definition statement

*This place covers:*

Illustrative example of subject matter classified in this group:

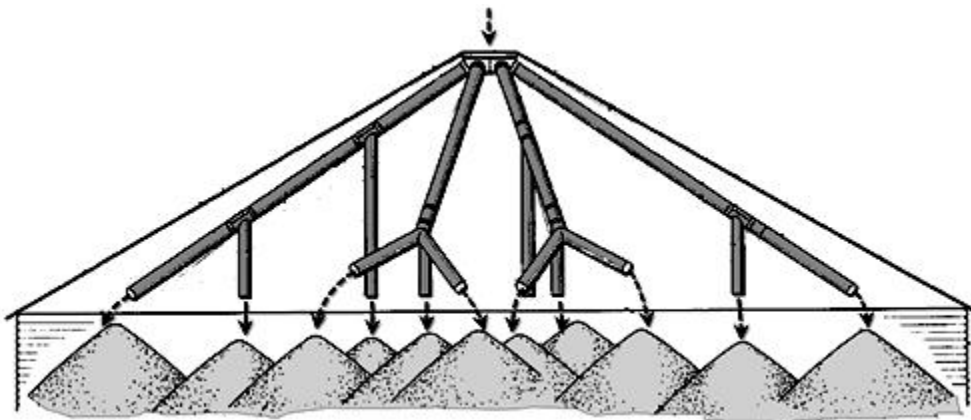

## References

### Limiting references

*This place does not cover:*

The means are supporting the material	<a href="#">B65G 69/0441</a>
The material is hit by the means	<a href="#">B65G 69/0458</a>

### Informative references

*Attention is drawn to the following places, which may be of interest for search:*

Deflector at the end of pneumatic feeding device	<a href="#">B65G 69/0491</a>
--------------------------------------------------	------------------------------

## B65G 69/045

{with scraping devices ([B65G 69/0416](#) takes precedence)}

### Definition statement

*This place covers:*

Illustrative example of subject matter classified in this group:

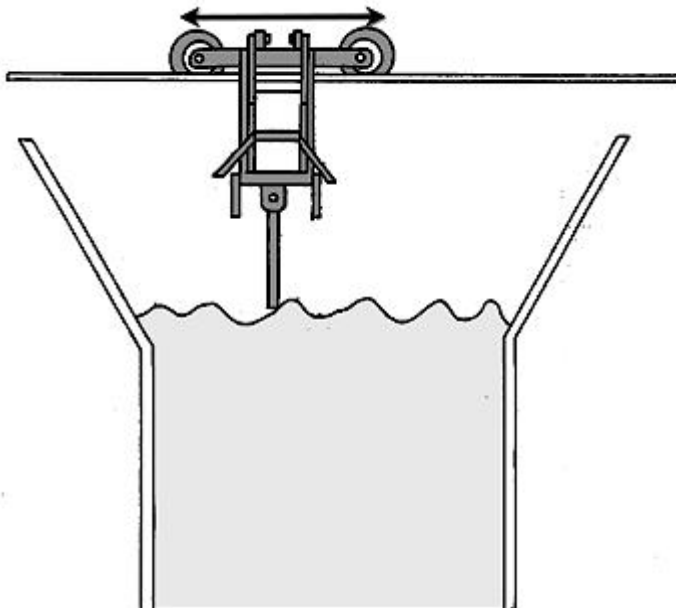

## References

### Limiting references

*This place does not cover:*

With scraping belts or chains	<a href="#">B65G 69/0416</a>
-------------------------------	------------------------------

**B65G 69/0458****{with rotating means, e.g. tables, arms}****Definition statement***This place covers:*

Illustrative example of subject matter classified in this group:

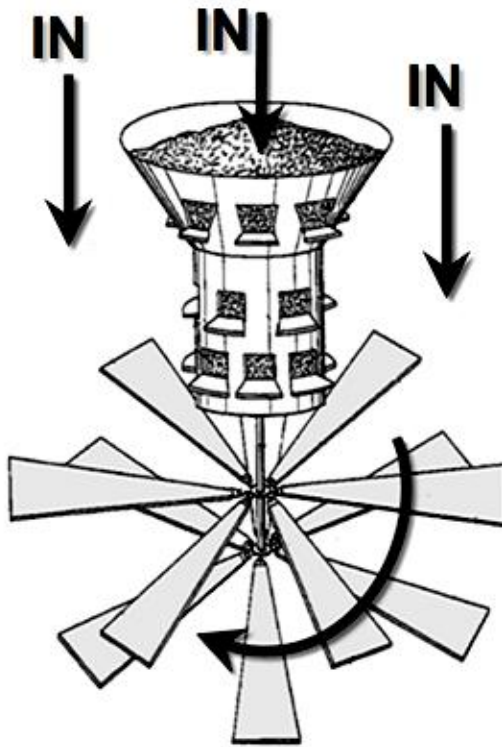
**References****Informative references***Attention is drawn to the following places, which may be of interest for search:*

With chutes, deflector means or channels	<a href="#">B65G 69/0441</a>
With throwing devices	<a href="#">B65G 69/0466</a>

**B65G 69/0466****{with throwing devices}****Definition statement***This place covers:*One feeding entry giving an impulse to the material (otherwise [B65G 69/0466](#))

Illustrative example of subject matter classified in this group:

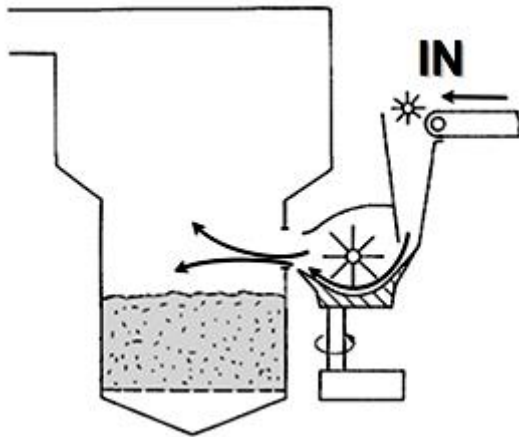

### B65G 69/0475

{with air jets}

#### Definition statement

*This place covers:*

Illustrative example of subject matter classified in this group:

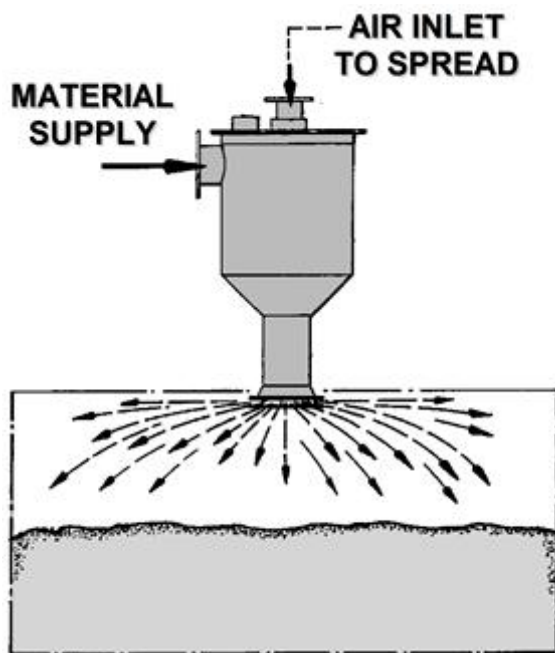



## B65G 69/0483

{with electric or magnetic means}

### Definition statement

*This place covers:*

Illustrative example of subject matter classified in this group:

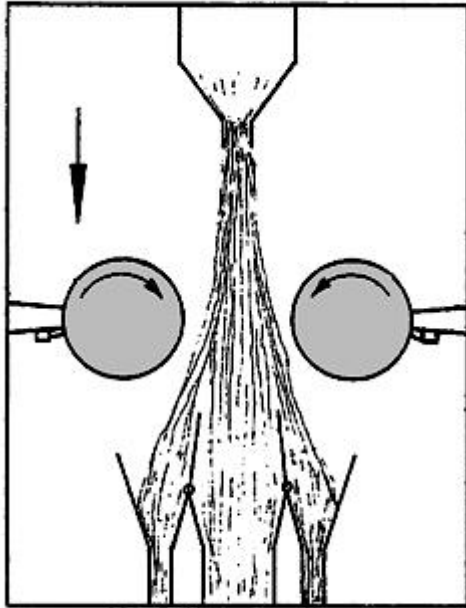

## B65G 69/0491

{with a pneumatic feeding conveyor}

### Definition statement

*This place covers:*

Illustrative example of subject matter classified in this group:

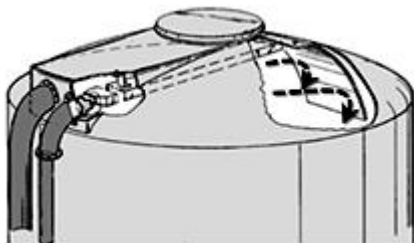

## B65G 69/08

Devices for emptying storage spaces as completely as possible (devices preventing the formation of bridges in large containers [B65D 88/64](#))

### Definition statement

*This place covers:*

Illustrative example of subject matter classified in this group:

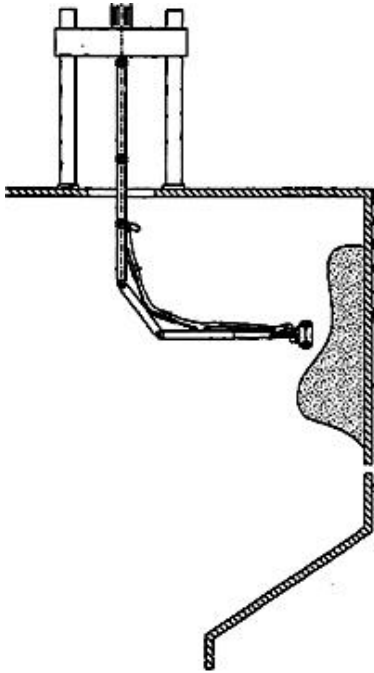

### References

#### Limiting references

*This place does not cover:*

Devices preventing the formation of bridges	<a href="#">B65D 88/64</a>
---------------------------------------------	----------------------------

#### Informative references

*Attention is drawn to the following places, which may be of interest for search:*

Loading or unloading	<a href="#">B65G 65/00</a>
Cleaning hollow articles by methods or apparatus specially adapted thereto	<a href="#">B08B 9/00</a>
Large containers	<a href="#">B65D 88/00</a>

## B65G 69/10

### Obtaining an average product from stored bulk material

#### Definition statement

*This place covers:*

Illustrative example of subject matter classified in this group:

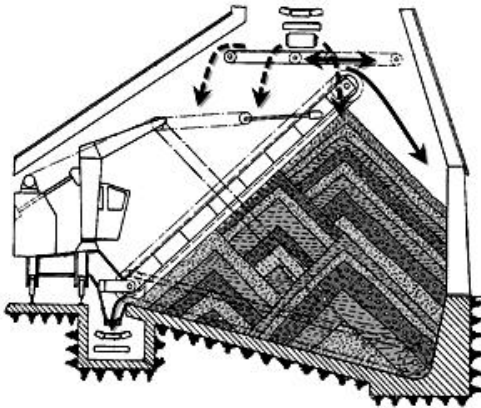

#### References

##### *Informative references*

*Attention is drawn to the following places, which may be of interest for search:*

Construction or shape of discharge section	<a href="#">B65D 88/28</a>
For measuring or testing	<a href="#">G01</a>

**B65G 69/12****Sieving bulk materials during loading or unloading****Definition statement**

*This place covers:*

Illustrative example of subject matter classified in this group:

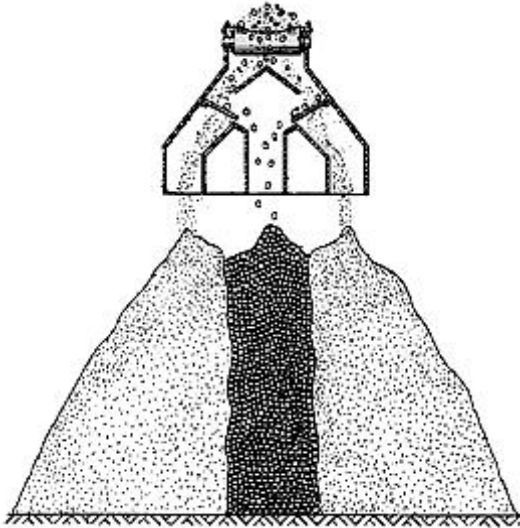
**References****Informative references**

Attention is drawn to the following places, which may be of interest for search:

Separating solid materials using liquids or using pneumatic tables or jigs	<a href="#">B03B</a>
----------------------------------------------------------------------------	----------------------

**B65G 69/14****Pulverising loaded or unloaded materials****Definition statement**

*This place covers:*

Illustrative example of subject matter classified in this group:

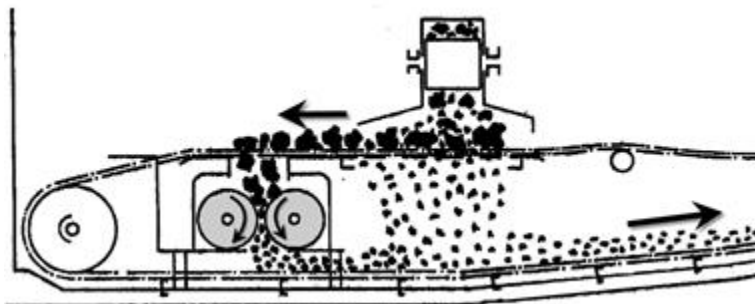

## References

### Informative references

Attention is drawn to the following places, which may be of interest for search:

Crushing	<a href="#">B02C</a>
Preventing bridges	<a href="#">B65D 88/64</a>
For coal mines	<a href="#">E21F 13/002</a>

## B65G 69/16

Preventing pulverisation, deformation, breakage, or other mechanical damage to the goods or materials

### Definition statement

This place covers:

Illustrative example of subject matter classified in this group:

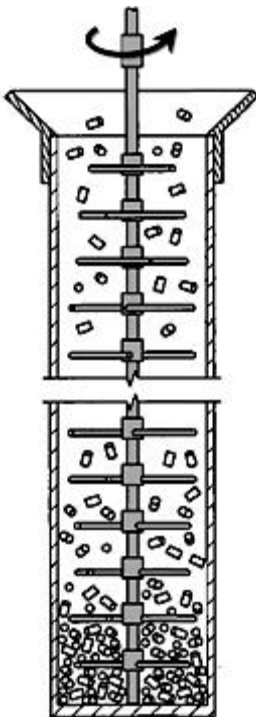

## References

### Informative references

Attention is drawn to the following places, which may be of interest for search:

Chutes with discontinuous guiding surfaces for bulk	<a href="#">B65G 11/088</a>
-----------------------------------------------------	-----------------------------

**B65G 69/165****{using descending or lowering endless conveyors}****Definition statement***This place covers:*

Illustrative example of subject matter classified in this group:

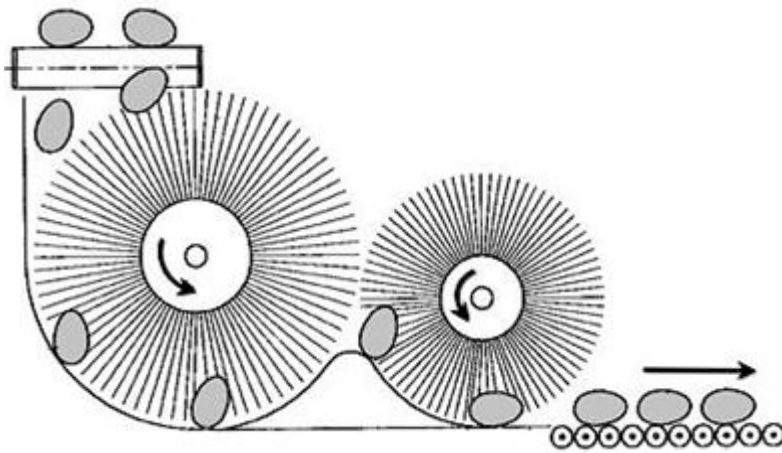
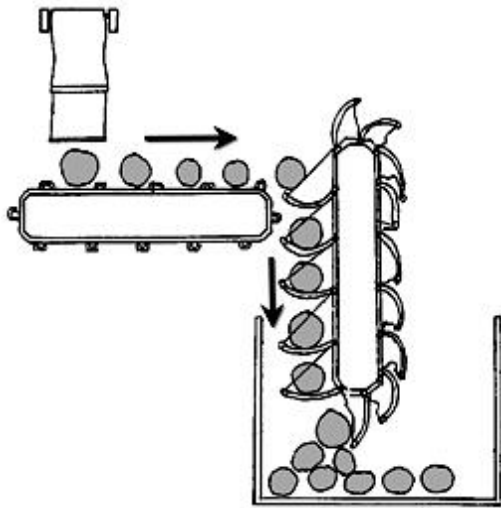
**References****Informative references***Attention is drawn to the following places, which may be of interest for search:*

Packaging fruits/vegetables in crates	<a href="#">B65B 25/046</a>
---------------------------------------	-----------------------------

## B65G 69/18

### Preventing escape of dust

#### References

##### *Informative references*

*Attention is drawn to the following places, which may be of interest for search:*

Preventing pulverisation of material	<a href="#">B65G 69/16</a>
--------------------------------------	----------------------------

## B65G 69/181

### {by means of sealed systems}

#### Definition statement

*This place covers:*

Illustrative example of subject matter classified in this group:

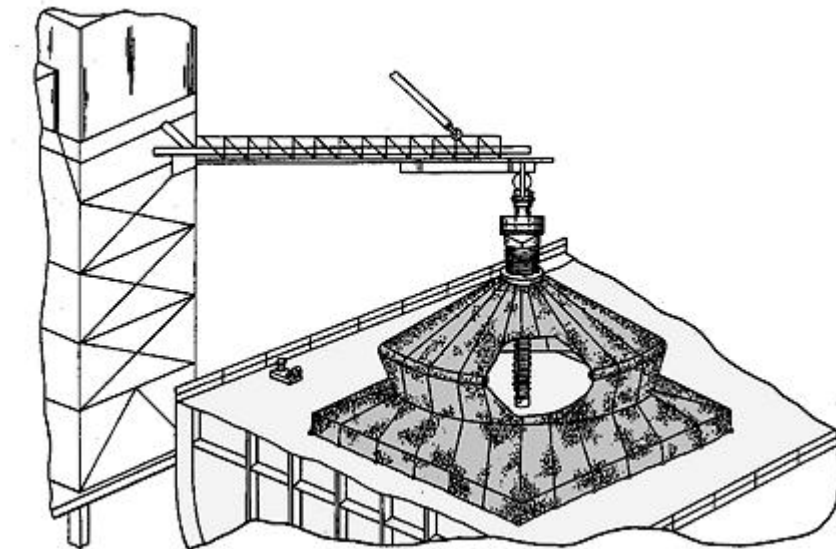

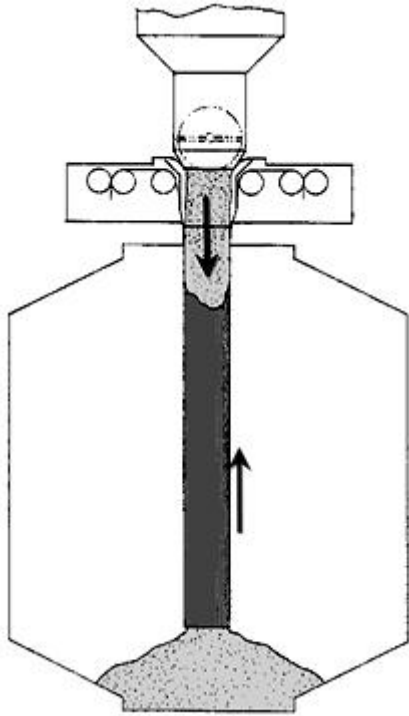

**B65G 69/182**

{with aspiration means}

**Definition statement**

*This place covers:*

Illustrative example of subject matter classified in this group:

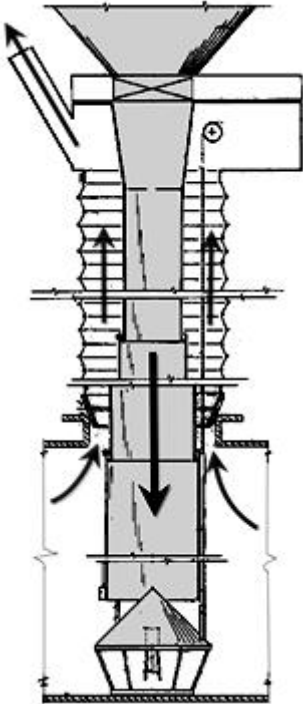



## B65G 69/183

{with co-operating closure members on each of the parts of a separable transfer channel}

### Definition statement

*This place covers:*

Illustrative example of subject matter classified in this group:

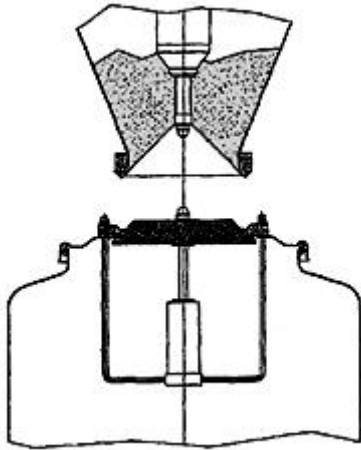

## B65G 69/185

{by means of non-sealed systems}

### Definition statement

*This place covers:*

Illustrative example of subject matter classified in this group:

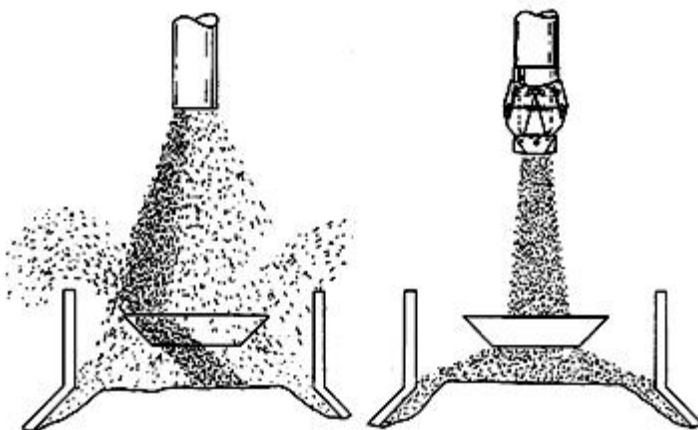

## B65G 69/186

{with aspiration means}

### Definition statement

*This place covers:*

Illustrative example of subject matter classified in this group:

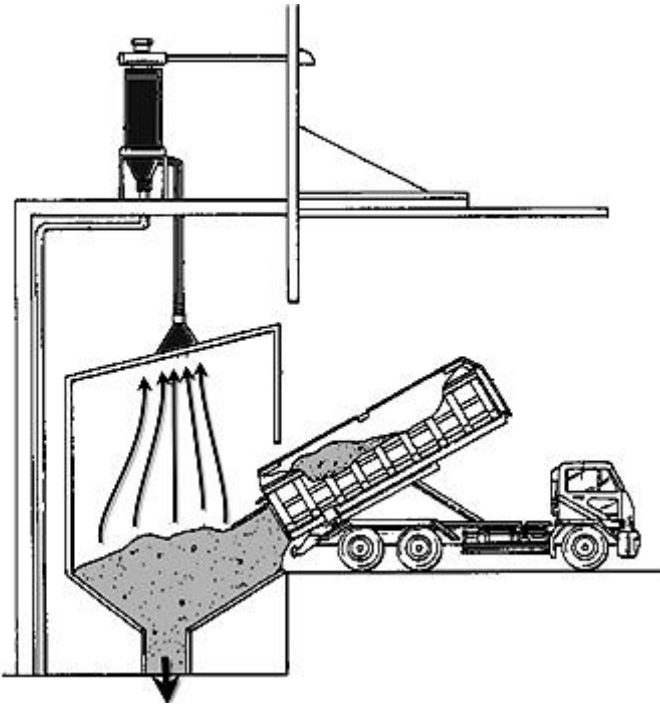

## B65G 69/187

{with non-return closures}

### Definition statement

*This place covers:*

Illustrative example of subject matter classified in this group:

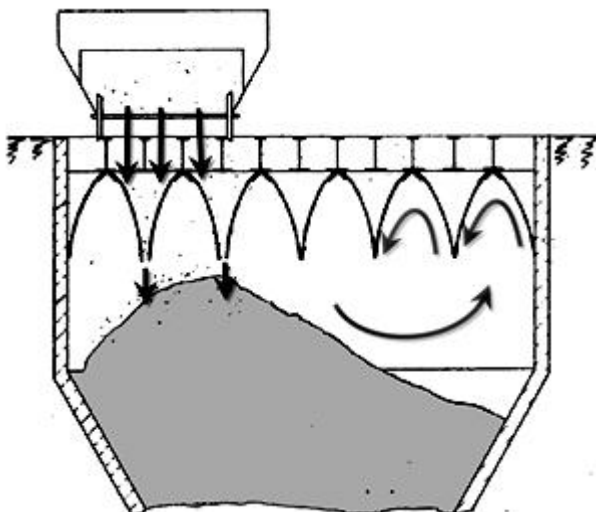

**B65G 69/188****{with spraying means}****Definition statement***This place covers:*

Illustrative example of subject matter classified in this group:

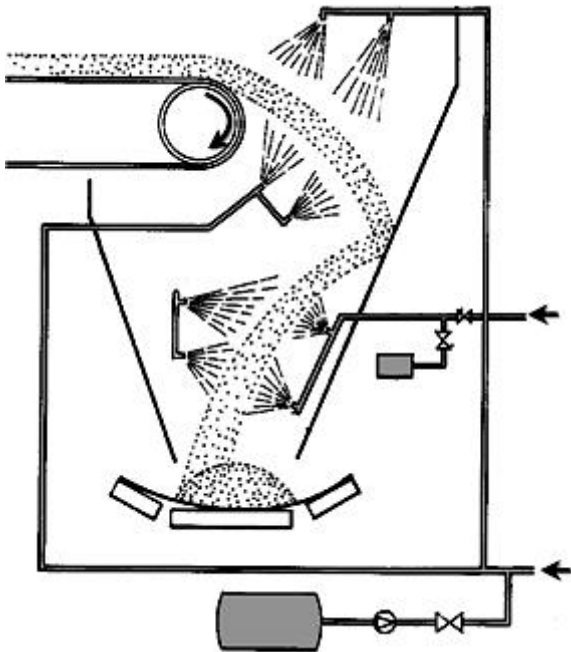
**B65G 69/20**

**Auxiliary treatments, e.g. aerating, heating, humidifying, deaerating, cooling, de-watering or drying, during loading or unloading; Loading or unloading in a fluid medium other than air**

**Definition statement***This place covers:*

Illustrative example of subject matter classified in this group:

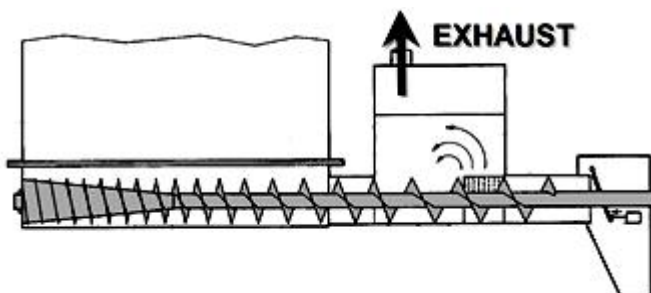

## References

### Informative references

Attention is drawn to the following places, which may be of interest for search:

Loading containers	<a href="#">B65G 69/02</a>
Spraying means	<a href="#">B65G 69/188</a>
Fluidising devices	<a href="#">B65D 88/72</a>

## B65G 69/22

Horizontal loading or unloading platforms (as road or railway equipment [B61B 1/00](#), [E01F 1/00](#))

### Definition statement

This place covers:

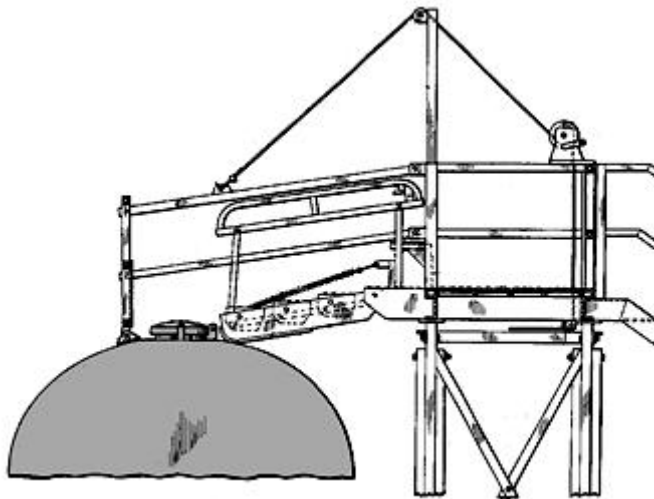

## References

### Limiting references

This place does not cover:

As road or railway equipment	<a href="#">B61B 1/00</a> , <a href="#">E01F 1/00</a>
------------------------------	-------------------------------------------------------

### Informative references

Attention is drawn to the following places, which may be of interest for search:

Piles Tables	<a href="#">B65H</a>
Scaffolds adjustable in height	<a href="#">E04G 1/20</a>

## B65G 69/24

having platform level adjusting means

### Definition statement

*This place covers:*

Illustrative example of subject matter classified in this group:

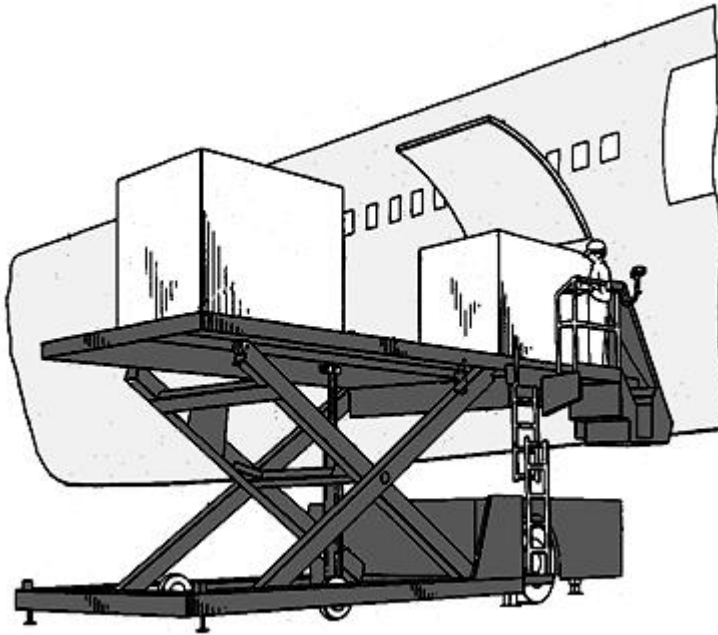

### References

#### Informative references

*Attention is drawn to the following places, which may be of interest for search:*

Handling freight in airports	<a href="#">B64D 9/00</a> , <a href="#">B64F 1/32</a>
Lifting platforms	<a href="#">B66F 7/00</a>

**B65G 69/26****Rotatable platforms****Definition statement**

*This place covers:*

Illustrative example of subject matter classified in this group:

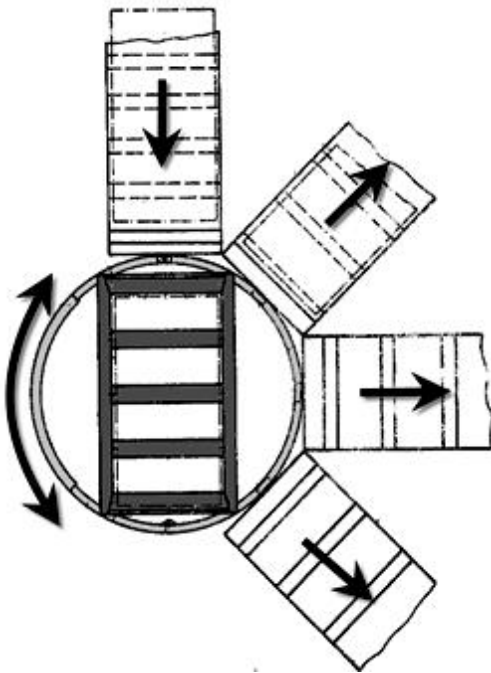
**B65G 69/28**

**Loading ramps; Loading docks (as road or railway equipment [B61B 1/00](#), [E01F 1/00](#))**

**References****Limiting references**

*This place does not cover:*

As road or railway equipment	<a href="#">B61B 1/00</a> , <a href="#">E01F 1/00</a>
------------------------------	-------------------------------------------------------

**Informative references**

*Attention is drawn to the following places, which may be of interest for search:*

Access to ambulance	<a href="#">A61G 3/061</a>
Loading ramp attached to vehicle truck	<a href="#">B60P 1/43</a>
Access to vehicles for impaired people	<a href="#">B60R 3/00</a>
Access to aircrafts	<a href="#">B64F 1/305</a>
Ramps helping a vehicle to access a lifting frame	<a href="#">B66F 7/243</a>
Access to ships	<a href="#">E01D 15/24</a>
Access to buildings for disabled people	<a href="#">E04F 11/02</a>

**B65G 69/2805****{permanently installed on the dock}****Definition statement***This place covers:*

Illustrative example of subject matter classified in this group:

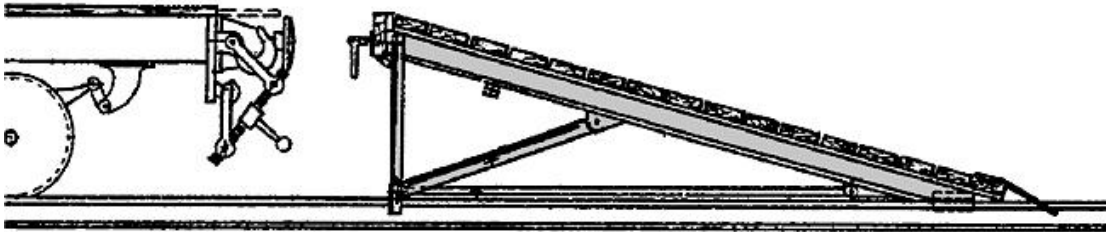
**B65G 69/2811****{pivoting ramps}****Definition statement***This place covers:*

Illustrative example of subject matter classified in this group:

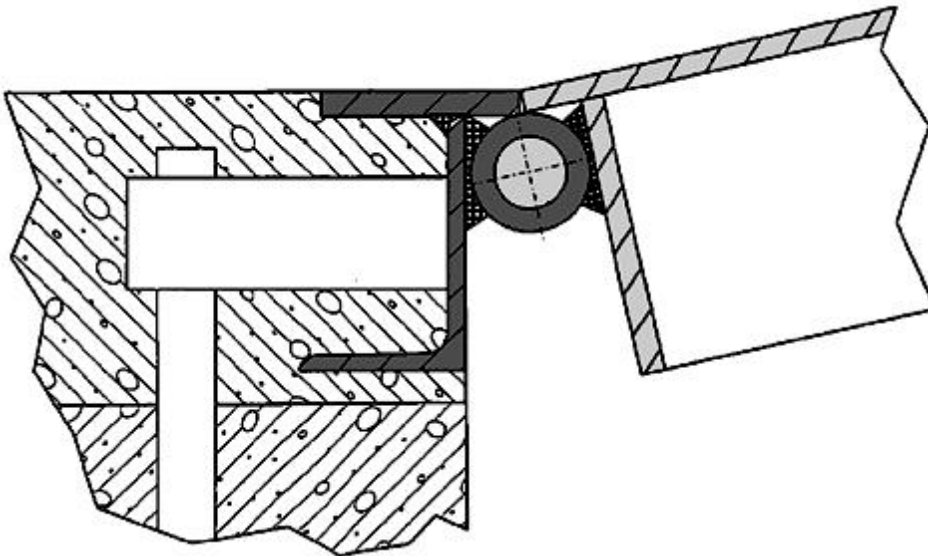
**References****Informative references***Attention is drawn to the following places, which may be of interest for search:*

Leveling vehicles	<a href="#">B65G 69/006</a>
-------------------	-----------------------------

## B65G 69/2817

{with fluid-operated means}

### Definition statement

*This place covers:*

Illustrative example of subject matter classified in this group:

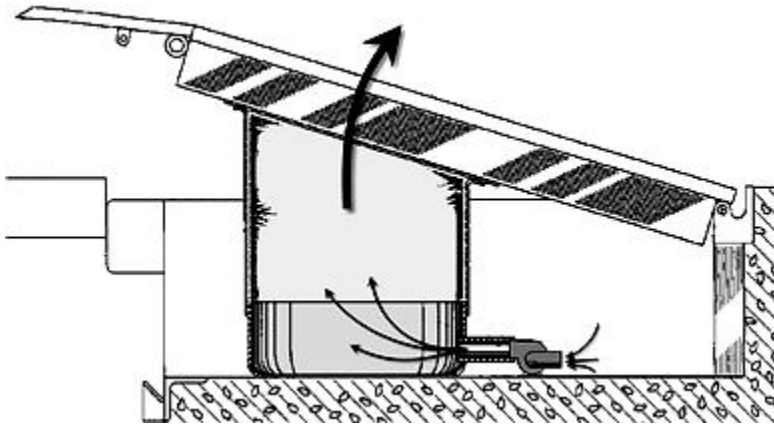

## B65G 69/2829

{extensible by sliding parts}

### Definition statement

*This place covers:*

Illustrative example of subject matter classified in this group:

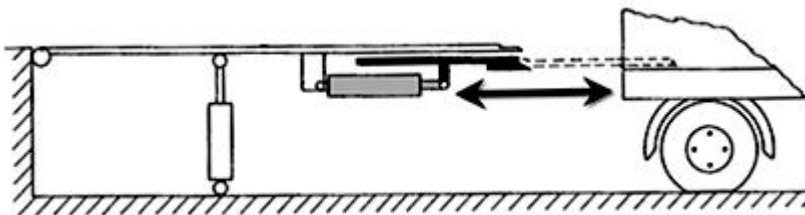



## B65G 69/2835

{with spring-operated means}

### Definition statement

*This place covers:*

Illustrative example of subject matter classified in this group:

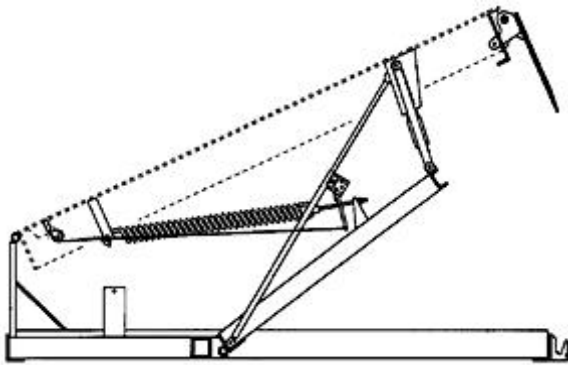

## B65G 69/2841

{extensible by pivoting parts}

### Definition statement

*This place covers:*

Illustrative example of subject matter classified in this group:

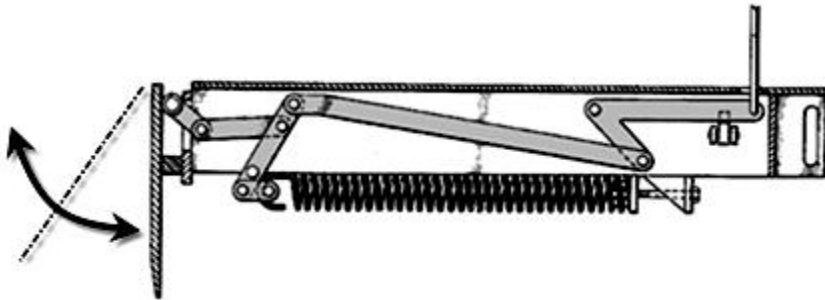

## B65G 69/2847

{extensible by sliding parts}

### Definition statement

*This place covers:*

Illustrative example of subject matter classified in this group:

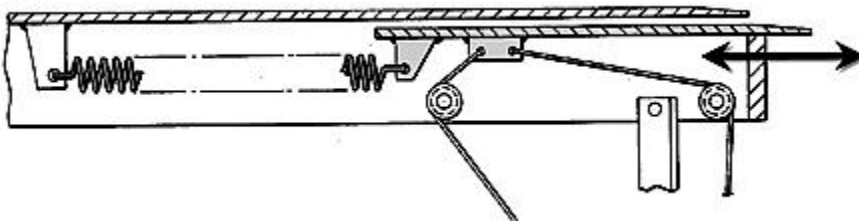

## B65G 69/2852

{with electric motor-operated means}

### Definition statement

*This place covers:*

Illustrative example of subject matter classified in this group:

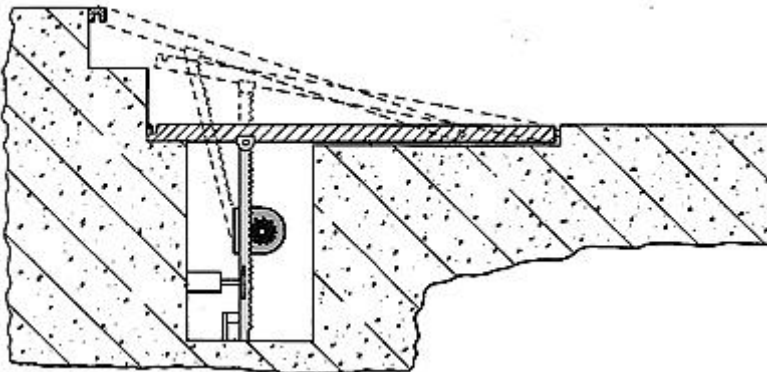

**B65G 69/2858****{with weight counterbalancing means}****Definition statement***This place covers:*

Illustrative example of subject matter classified in this group:

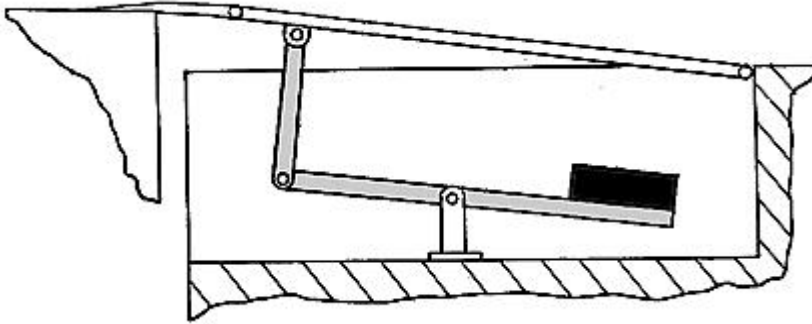
**B65G 69/2864****{adjustable with respect to the dock}****Definition statement***This place covers:*

Illustrative example of subject matter classified in this group:

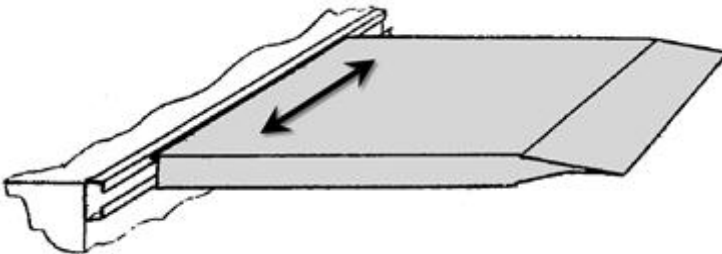
**References****Informative references***Attention is drawn to the following places, which may be of interest for search:*

Floating ramps	<a href="#">B63B 27/143</a>
----------------	-----------------------------

## **B65G 69/287**

**{Constructional features of deck or surround}**

### **Definition statement**

*This place covers:*

Illustrative example of subject matter classified in this group:

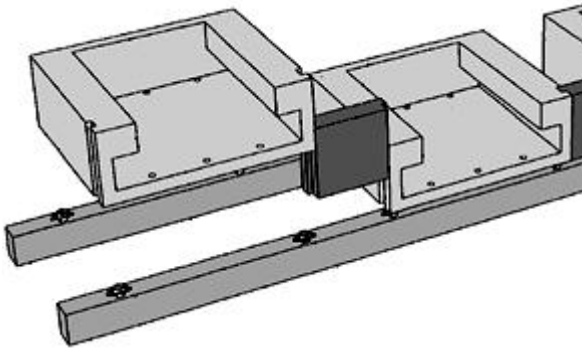

## **B65G 69/2876**

**{Safety or protection means, e.g. skirts}**

### **Definition statement**

*This place covers:*

Illustrative example of subject matter classified in this group:

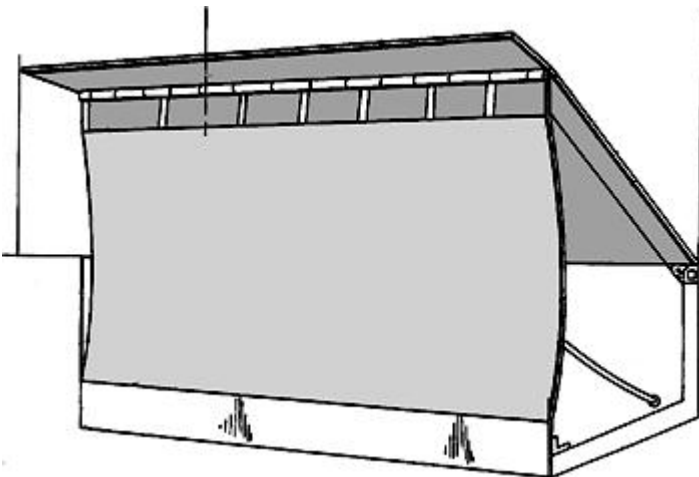

## B65G 69/2882

{operated by detectors or sensors}

### Definition statement

*This place covers:*

Illustrative example of subject matter classified in this group:

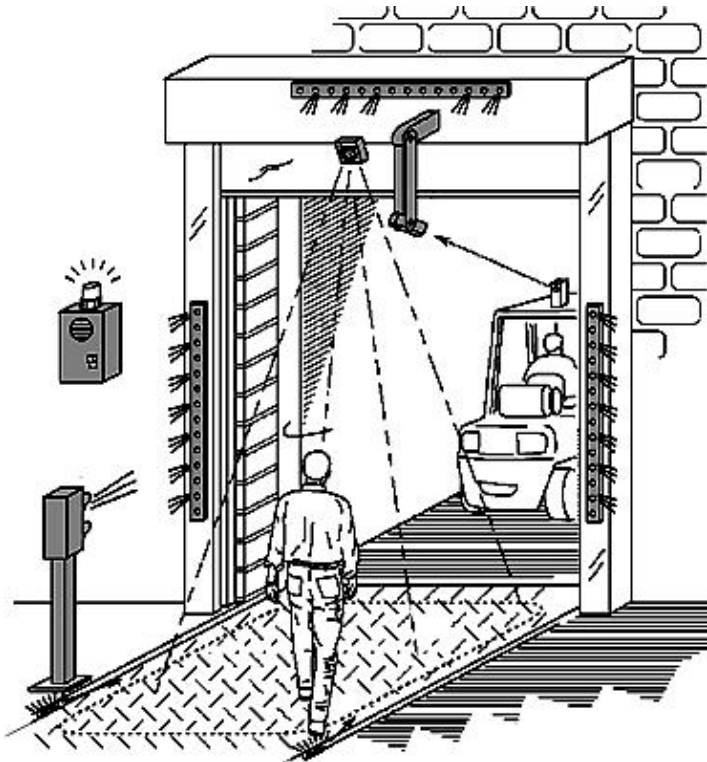

## B65G 69/2888

{Vehicle barriers mounted on deck}

### Definition statement

*This place covers:*

Illustrative example of subject matter classified in this group:

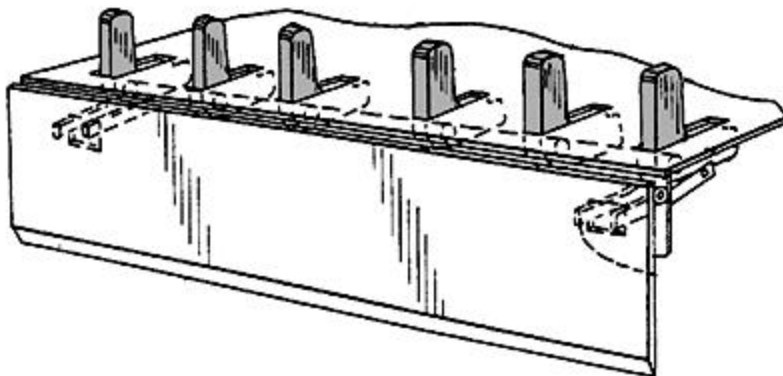

**B65G 69/2894****{Safety legs}****Definition statement***This place covers:*

Illustrative example of subject matter classified in this group:

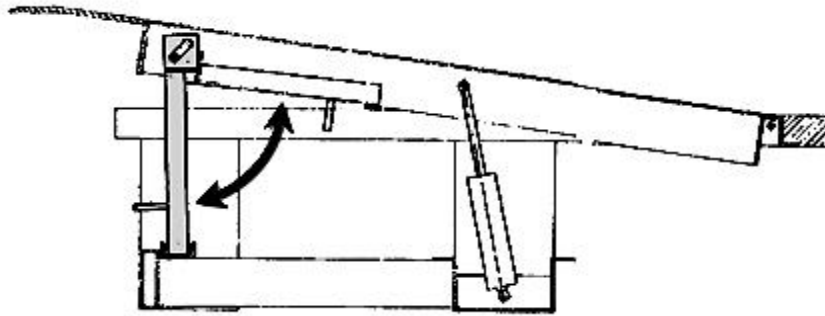
**B65G 69/30****Non-permanently installed loading ramps, e.g. transportable****Definition statement***This place covers:*

Illustrative example of subject matter classified in this group:

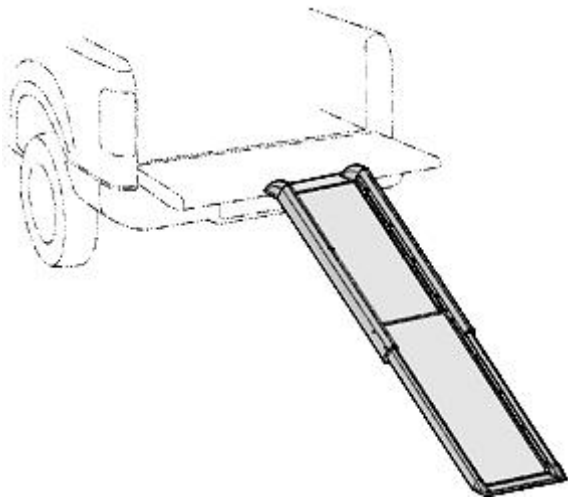
**References****Limiting references***This place does not cover:*

Ramps fixed to or part of vehicles	<a href="#">B60P</a>
------------------------------------	----------------------