

E05F

DEVICES FOR MOVING WINGS INTO OPEN OR CLOSED POSITION; CHECKS FOR WINGS; WING FITTINGS NOT OTHERWISE PROVIDED FOR, CONCERNED WITH THE FUNCTIONING OF THE WING

Definition statement

This place covers:

Devices for moving wings, such as doors or windows, into open or closed position; checks for wings, such as doors or windows; wing fittings not otherwise provided for, concerned with the functioning of the wing.

Gravity-, spring-, or power-operated devices to provide a force input for opening or closing wings, such as door openers and door closers, self-closing hinges and hinges with wing-counterbalancing function.

Also covered are operating mechanisms for wings constructed to convert the force input from a user, motor, opener or closer into movement of a wing, such as cable-, cord-, chain-, or belt-drives, lifting arms, rack and pinion drives or screw and nut arrangements.

The subclass furthermore covers braking devices, stops and buffers for wings as well as controlling means, such as remote wireless control means, and safety devices such as obstruction detection devices.

Relationships with other classification places

Hinges and other suspension devices for wings in [E05D](#).

Locks for doors and windows in [E05B](#) and [E05C](#).

Construction of doors, windows, gates and frames in buildings in [E06B](#).

Construction of doors, windows, and other moveable wings in vehicles in [B60J](#).

References

Limiting references

This place does not cover:

Counterbalancing means for sliding or lifting wings	E05D 13/10
---	----------------------------

Informative references

Attention is drawn to the following places, which may be of interest for search:

Operating or controlling devices for fire-barriers	A62C 2/24
Operating mechanisms for safeguarding bank teller windows	E05G 5/00
Operating mechanisms for interconnected lamellae	E06B 7/086
Operating mechanisms for blinds or roll-type closures	E06B 9/00
Springs per se	F16F
Electric motors per se	H02K , H02P

Special rules of classification

Closers, openers, braking devices, stops and buffers for wings: [E05F 1/00](#), [E05F 3/00](#) and [E05F 5/00](#).

Special rules of classification

Accessories for wings: [E05F 7/00](#).

Operating mechanisms for wings: [E05F 9/00](#), [E05F 11/00](#), [E05F 13/00](#), [E05F 15/00](#) and [E05F 17/00](#).

Controlling means, such as remote wireless control means, and safety devices such as obstruction detection devices: [E05F 15/00](#).

A number of main groups in this sub-class contain a large number of older documents that were classified administratively. These documents have not yet been classified into the sub-groups and are indexed with [E05Y 2800/00](#). This index should not be used for classification.

Under [E05Y 2900/00](#) and lower an indexing scheme exists for information on the application or use of the devices. The indexing scheme is shared with the sub-class [E05D](#).

Glossary of terms

In this place, the following terms or expressions are used with the meaning indicated:

Braking device	Devices constructed to slow down the movement of wings
Closer	Gravity-, spring- or power-operated device constructed to provide a closing force to wings over a substantial part of their movement; includes devices for assisting users in wing-movement or for wing-counterbalancing; a closer can take the shape of a self-closing hinge
Opener	Gravity-, spring- or power-operated device constructed to provide an opening force to wings over a substantial part of their movement; includes devices for assisting users in wing-movement or for wing-counterbalancing
Operating mechanism for wings	Mechanism constructed to convert force inputs from a user, motor, opener or closer into movement of wings
Self-closing hinge	Gravity- or spring-operated hinge constructed to provide a closing force to wings over a substantial part of their movement; includes devices for wing-counterbalancing
Vehicle	Land vehicles, e.g. cars, trucks, buses or trains
Wing	Pivotable, slideable, or otherwise moveable part of doors, windows, flaps, covers or similar structures to prevent traffic through a passageway in building construction and outfitting, fences, domestic appliances, vehicles and furniture; the term also includes drawers, lids of chests, car boots/trunks or car bonnets/hoods

E05F 1/00

Closers or openers for wings, not otherwise provided for in this subclass

Definition statement

This place covers:

Gravity-, or spring-operated closers or openers for wings including those in the shape of hinges, i.e. self-closing hinges.

Relationships with other classification places

Power-operated door closers or openers in [E05F 15/00](#).

E05F 1/002

{controlled by automatically acting means (for powered-operated mechanisms [E05F 15/70](#))}

References**Informative references**

Attention is drawn to the following places, which may be of interest for search:

Automatically acting control means for powered-operated mechanisms	E05F 15/70
--	----------------------------

E05F 1/004

{by thermostats, rain, wind or noise ([E05F 1/006](#) takes precedence)}

References**Limiting references**

This place does not cover:

Automatically acting control means triggered by emergency conditions such as fire	E05F 1/006
---	----------------------------

E05F 1/006

{by emergency conditions, e.g. fire (operating or controlling mechanisms for physical fire-barriers [A62C 2/24](#))}

References**Limiting references**

This place does not cover:

Operating or controlling mechanisms for physical fire-barriers	A62C 2/24
--	---------------------------

E05F 1/043

{with cams, helical tracks ([E05F 1/061](#) takes precedence)}

References**Limiting references**

This place does not cover:

Gravity-actuated self-closing hinges with cams and helical tracks	E05F 1/061
---	----------------------------

Glossary of terms

In this place, the following terms or expressions are used with the meaning indicated:

Self-closing hinge	Gravity-operated hinge constructed to provide a closing force to wings over a substantial part of their movement; includes devices for wing-counterbalancing
--------------------	--

E05F 1/063

{with complementary, substantially identical and slidingly cooperating cam surfaces ([E05F 1/066](#) takes precedence)}

References**Limiting references**

This place does not cover:

Gravity-actuated self-closing hinges with helical grooves, slots, threads or the like	E05F 1/066
---	----------------------------

Glossary of terms

In this place, the following terms or expressions are used with the meaning indicated:

Self-closing hinge	Gravity-operated hinge constructed to provide a closing force to wings over a substantial part of their movement; includes devices for wing-counterbalancing
--------------------	--

E05F 1/08

spring-actuated {, e.g. for horizontally sliding wings (counterbalancing sliding or lifting wings [E05D](#); springs per se [F16F](#), e.g. gas-springs [F16F 9/00](#)}

Relationships with other classification places

Springs per se in [F16F](#).

References**Limiting references**

This place does not cover:

Spring-actuated counterbalancing of sliding or lifting wings	E05D 13/12
--	----------------------------

E05F 1/10

for swinging wings {, e.g. counterbalance}

References**Informative references**

Attention is drawn to the following places, which may be of interest for search:

Spring-assisted actuation of lids or covers of refuse receptacles	B65F 1/1623
---	-----------------------------

E05F 1/1008

{with a coil spring parallel with the pivot axis ([E05F 1/1207](#) takes precedence)}

References**Limiting references**

This place does not cover:

Spring-actuated self-closing hinges with a coil spring parallel with the pivot axis	E05F 1/1207
---	-----------------------------

Glossary of terms

In this place, the following terms or expressions are used with the meaning indicated:

Self-closing hinge	Spring-operated hinge constructed to provide a closing force to wings over a substantial part of their movement; includes devices for wing-counterbalancing
--------------------	---

E05F 1/1033

{with a torsion bar ([E05F 1/123](#) takes precedence)}

References**Limiting references**

This place does not cover:

Spring-actuated self-closing hinges with a torsion bar	E05F 1/123
--	----------------------------

Glossary of terms

In this place, the following terms or expressions are used with the meaning indicated:

Self-closing hinge	Spring-operated hinge constructed to provide a closing force to wings over a substantial part of their movement; includes devices for wing-counterbalancing
--------------------	---

E05F 1/1041

{with a coil spring perpendicular to the pivot axis ([E05F 1/1246](#) takes precedence)}

References**Limiting references**

This place does not cover:

Spring-actuated self-closing hinges with a coil spring perpendicular to the pivot axis	E05F 1/1246
--	-----------------------------

Glossary of terms

In this place, the following terms or expressions are used with the meaning indicated:

Self-closing hinge	Spring-operated hinge constructed to provide a closing force to wings over a substantial part of their movement; includes devices for wing-counterbalancing
--------------------	---

E05F 1/1083

{with a leaf or similar spring ([E05F 1/1284](#) takes precedence)}

References**Limiting references**

This place does not cover:

Spring-actuated self-closing hinges with a leaf or similar spring	E05F 1/1284
---	-----------------------------

Glossary of terms

In this place, the following terms or expressions are used with the meaning indicated:

Self-closing hinge	Spring-operated hinge constructed to provide a closing force to wings over a substantial part of their movement; includes devices for wing-counterbalancing
--------------------	---

E05F 1/1091

{with a gas spring ([E05F 1/1292](#) takes precedence)}

References**Limiting references**

This place does not cover:

Spring-actuated self-closing hinges with a gas spring	E05F 1/1292
---	-----------------------------

Glossary of terms

In this place, the following terms or expressions are used with the meaning indicated:

Self-closing hinge	Spring-operated hinge constructed to provide a closing force to wings over a substantial part of their movement; includes devices for wing-counterbalancing
--------------------	---

E05F 1/12

Mechanisms in the shape of hinges or pivots, operated by springs

References

Informative references

Attention is drawn to the following places, which may be of interest for search:

Hinges with springs applying a holding force, e.g. a hold-closed force to hold the hinge and respective wing in an immobile closed position	E05D 11/1014
---	------------------------------

Special rules of classification

If the hinges comprises two or more pins, [E05D 3/06](#) applies in addition to [E05F 1/12](#).

E05F 3/00

Closers or openers with braking devices, e.g. checks; Construction of pneumatic or liquid braking devices (construction of non-pneumatic or non-liquid braking devices [E05F 5/00](#); friction devices in hinges [E05D 11/08](#))

Definition statement

This place covers:

Closers and openers, including self-closing hinges, with integrated braking devices such as rotary or piston fluid brakes, friction brakes or counteracting springs.

Construction of braking devices for such closers and openers.

Closers with integrated braking devices and additional arrangements, e.g. holding the wing open or assisting in opening the wing.

Relationships with other classification places

Construction of non-pneumatic or non-liquid braking devices for wings are classified in [E05F 5/00](#) and subgroups.

Stops and buffers for wings are classified in [E05F 5/00](#) and subgroups.

References

Informative references

Attention is drawn to the following places, which may be of interest for search:

Construction of non-pneumatic or non-liquid braking devices	E05F 5/00
Friction devices in hinges to hold relatively-moveable hinge parts and consequently wings in a user-chosen position	E05D 11/08

Special rules of classification

References [E05F 5/00](#) and [E05D 11/08](#) are non-limiting in the main group [E05F 3/00](#). CPC will be corrected once this inconsistency is resolved in IPC.

E05F 3/02with pneumatic piston brakes (rotary type [E05F 3/14](#))**References****Informative references***Attention is drawn to the following places, which may be of interest for search:*

Pneumatic piston brakes of rotary type	E05F 3/14
--	---------------------------

E05F 3/04with liquid piston brakes (rotary type [E05F 3/14](#))**References****Informative references***Attention is drawn to the following places, which may be of interest for search:*

Liquid piston brakes of rotary type	E05F 3/14
-------------------------------------	---------------------------

E05F 3/12**Special devices controlling the circulation of the liquid, e.g. valve arrangement** ([E05F 3/223](#) takes precedence); valves per se [F16K](#))**Relationships with other classification places**Valves per se in [F16K](#)**References****Limiting references***This place does not cover:*

Hydraulic power-locks in closers	E05F 3/223
----------------------------------	----------------------------

E05F 3/16

with friction brakes

References**Limiting references***This place does not cover:*

Friction devices in hinges to hold relatively-moveable hinge parts and consequently wings in a user-chosen position	E05D 11/08
---	----------------------------

Glossary of terms*In this place, the following terms or expressions are used with the meaning indicated:*

Brake	device constructed to slow down the movement of a wing
-------	--

E05F 3/18

with counteracting springs (double-acting springs [E05F 1/14](#))

References

Informative references

Attention is drawn to the following places, which may be of interest for search:

Double-acting springs, e.g. for closing and opening or checking and closing	E05F 1/14
---	---------------------------

E05F 3/22

Additional arrangements for closers, e.g. for holding the wing in opened or other position

References

Informative references

Attention is drawn to the following places, which may be of interest for search:

Braking devices combined with devices for holding the wing open	E05C 17/00
Friction devices between relatively-movable hinge parts	E05D 11/08
Devices for preventing movement between relatively-movable hinge parts	E05D 11/10

E05F 3/221

{Mechanical power-locks, e.g. for holding the wing open or for free-moving zones}

Glossary of terms

In this place, the following terms or expressions are used with the meaning indicated:

Mechanical power-lock	Mechanically operated lock for holding wing in position other than closed – includes spring operated
-----------------------	--

E05F 5/00

Braking devices, e.g. checks; Stops; Buffers (construction of pneumatic or liquid braking devices [E05F 3/00](#); braking devices, buffers or end stops on drawers for tables, cabinets or like furniture [A47B 88/473](#); combined with devices for holding wings open [E05C 17/00](#); devices for limiting opening of wings or for holding wings open by a movable member extending between frame and wing [E05C 17/04](#))

Definition statement

This place covers:

Construction of braking devices, stops and buffers for wings.

References

Limiting references

This place does not cover:

Construction of pneumatic or liquid braking devices	E05F 3/00
Braking devices, buffers or end stops on drawers for tables, cabinets or like furniture	A47B 88/473
Braking devices combined with devices for holding the wing	E05C 17/00
Devices for limiting opening of wings	E05C 17/04

Informative references

Attention is drawn to the following places, which may be of interest for search:

Indexing scheme related to brakes, disengaging means, holders, stops and valves	E05Y 2201/20
---	------------------------------

Special rules of classification

[E05F 5/00](#) provides classification entries for braking devices, stops or buffers associated with wings characterised by their wing movement.

The indexing codes under [E05Y 2201/20](#) are used to classify further details not available in the main trunk. In particular, the indexing codes as foreseen under [E05Y 2201/21](#) and [E05Y 2201/224](#) are used to classify braking devices, stops or buffers combined with motors associated with wings.

The indexing codes under [E05Y 2201/21](#) and [E05Y 2201/224](#) are however not applied when classification symbols in [E05F 5/00](#) or subgroups are being allocated for inventive information.

Looping references between [E05F 5/00](#) and [E05F 3/00](#) have been identified. Until this inconsistency is resolved in IPC, the current classification practice in CPC is as follows: Reference [E05F 3/00](#) is limiting in the subgroup [E05F 5/00](#). CPC will be corrected once this inconsistency is resolved in IPC.

E05F 7/00

Accessories for wings not provided for in other groups of this subclass (specially adapted for furniture [A47B 95/00](#); door-lifters [B66F](#), [E04F 21/00](#); knobs or handles [E05B](#))

Definition statement

This place covers:

Accessories or devices providing additional control to the wing, e.g. devices for alignment of the wing, rattling control, or devices to take the wing's weight arranged away from a hinge axis.

Relationships with other classification places

Accessories for sliding or lifting wings in [E05D 13/00](#)

Accessories for hinges in [E05D 11/00](#)

Door lifters in [B66F](#)

Knobs and handles in [E05B](#)

References**Limiting references**

This place does not cover:

Accessories for wings, adapted for furniture	A47B 95/00
Door lifters	B66F , E04F 21/00
Knobs or handles	E05B

Informative references

Attention is drawn to the following places, which may be of interest for search:

Counterbalance devices for sliding or lifting wings	E05D 13/10
---	----------------------------

E05F 7/02

for raising wings before being turned {(before sliding [E05D 15/565](#))}

References**Informative references**

Attention is drawn to the following places, which may be of interest for search:

Accessories for raising wings before sliding	E05D 15/565
--	-----------------------------

E05F 7/04

Arrangements affording protection against rattling (with buffering action [E05F 5/00](#))

References**Informative references**

Attention is drawn to the following places, which may be of interest for search:

Arrangements with buffering action	E05F 5/00
------------------------------------	---------------------------

E05F 7/08

Means for transmitting movements between vertical and horizontal sliding bars, rods, or cables (means for transmitting movements between vertical and horizontal sliding bars, rods, or cables, for the fastening of wings [E05C 9/24](#) {; with means for transmitting movements between vertical and horizontal sliding bars, rods or cables [E05D 15/5208](#)})

References

Limiting references

This place does not cover:

Means for transmitting movements between vertical and horizontal sliding bars, rods, or cables in wings opening about a vertical as well as a horizontal axis	E05D 15/5208
---	------------------------------

Informative references

Attention is drawn to the following places, which may be of interest for search:

Means for transmitting movements between vertical and horizontal sliding bars, rods or cables, for the fastening of wings	E05C 9/24
---	---------------------------

Special rules of classification

Looping references between [E05F 7/08](#) and [E05C 9/24](#) have been identified. Until this inconsistency is resolved in IPC, the current classification practice in CPC is as follows: References [E05C 9/24](#) and [E05F 7/08](#) are non-limiting. CPC will be corrected once this inconsistency is resolved in IPC.

E05F 9/00

Means for operating wings by hand rods not guided in or on the frame, including those which also operate the fastening (bolts or fastening devices for wings [E05C](#))

Definition statement

This place covers:

Hand-held rods constructed to operate wing bolts or fastenings and to operate by hand the wings per se.

Relationships with other classification places

Bolts or fastening devices for wings in [E05C](#)

Gravity-, or spring-operated closers or openers for wings in [E05F 1/00](#)

Power-operated door closers or openers in [E05F 15/00](#)

E05F 11/00

Man-operated mechanisms for operating wings, including those which also operate the fastening (connecting mechanisms for a plurality of wings [E05F 17/00](#))

Definition statement

This place covers:

Operating mechanisms in wings, casings or frames constructed to convert the manual force input from a user into movement of a wing, such as belt-, cable-, cord-, or chain-drives, lifting arms, rack and pinion drives or screw and nut arrangements.

Relationships with other classification places

Operating mechanisms for wings constructed to convert the force input from a motor into movement of a wing are classified in [E05F 15/603](#).

Operating mechanisms for wings constructed to convert the force input from the weight of a person or vehicle into movement of a wing are classified in [E05F 13/00](#).

References

Informative references

Attention is drawn to the following places, which may be of interest for search:

Connecting mechanisms for a plurality of wings	E05F 17/00
--	----------------------------

E05F 11/02

for wings in general, e.g. fanlights ([E05F 11/36](#) takes precedence; for windows to be lowered vertically [E05F 11/38](#); for doors [E05F 11/54](#))

References

Limiting references

This place does not cover:

Mechanisms specially designed for passing through a wall	E05F 11/36
--	----------------------------

Informative references

Attention is drawn to the following places, which may be of interest for search:

Mechanisms for sliding windows, e.g. vehicle windows, to be opened or closed by vertical movement	E05F 11/38
Mechanisms for doors	E05F 11/54

E05F 11/32

with rotary bars guided in the frame ([E05F 11/34](#) takes precedence)

References**Limiting references**

This place does not cover:

Screw and nut mechanisms	E05F 11/34
--------------------------	----------------------------

E05F 11/38

for sliding windows, e.g. vehicle windows, to be opened or closed by vertical movement

References**Informative references**

Attention is drawn to the following places, which may be of interest for search:

Electrical power-operated mechanisms for vertically-sliding wings specially adapted for vehicle windows	E05F 15/689
---	-----------------------------

E05F 13/00

Mechanisms operated by the movement or weight of a person or vehicle (through power-operated wing-operating mechanisms [E05F 15/00](#))

Definition statement

This place covers:

Operating mechanisms for wings constructed to convert the force input from the weight of a person or vehicle into movement of a wing.

Relationships with other classification places

Operating mechanisms constructed to convert the manual force input from a user into movement of a wing in [E05F 11/00](#)

Operating mechanisms for wings constructed to convert the force input from a motor into movement of a wing in [E05F 15/603](#)

E05F 15/00

Power-operated mechanisms for wings (motor-operated accessories in locks for completing closing or initiating opening of a wing [E05B 17/00](#))

Definition statement

This place covers:

Operating mechanisms for wings constructed to convert the force input from a motor into movement of a wing.

The group furthermore covers safety devices for power-operated wings, such as obstruction detection means, and controlling means, such as remote wireless controls means.

References

Informative references

Attention is drawn to the following places, which may be of interest for search:

Power-operated mechanisms for hatch covers in ships	B63B 19/14
Power-operated mechanisms for elevator doors	B66B 13/00
Power-operated mechanisms for completing closing or initiating opening of a wing	E05B 17/0029
Limit switches	H01H 3/16

Synonyms and Keywords

In patent documents, the following words/expressions are often used with the meaning indicated:

"power-operated"	" motor-operated ".
------------------	---------------------

E05F 15/40

Safety devices, e.g. detection of obstructions or end positions

References

Informative references

Attention is drawn to the following places, which may be of interest for search:

Automatically-acting means, e.g. by photoelectric cells, by electric waves, by thermostats, by rain, by fire	E05F 15/70
Anti-dropping devices	E05D 13/003
Indexing code related to safety means during manual wing operation	E05Y 2400/3017
Indexing scheme related to safety arrangements associated with the wing motor	E05Y 2400/52
Indexing scheme related to physical protection, e.g. against corrosion, finger injury or unintended use	E05Y 2800/40
Detection of obstructions by current overload	H02H 7/0851

Special rules of classification

[E05F 15/40](#) provides classification entries for safety devices associated with motor-driven wings. The indexing codes under [E05Y 2400/52](#) are used to classify further details not available in the main trunk. [E05Y 2400/55](#) - [E05Y 2400/564](#) are in particular allocated in combination with [E05F 15/41](#).

E05F 15/41

Detection by monitoring transmitted force or torque ([E05F 15/48](#) takes precedence); Safety couplings with activation dependent upon torque or force, e.g. slip couplings

References**Limiting references**

This place does not cover:

Detection by means of monitoring transmitted force or torque by transmission of mechanical forces, e.g. using rigid, movable members	E05F 15/48
Detection by means of monitoring transmitted force or torque in pressure medium-operated mechanisms for wings	E05F 15/49

E05F 15/42

Detection using safety edges

Definition statement

This place covers:

Detection of obstructions using devices mounted on the edge of the wing or mounted adjacent to or in the closing path of the wing.

E05F 15/49

pecially adapted for mechanisms operated by fluid pressure, e.g. detection by monitoring transmitted fluid pressure ([E05F 15/47](#) takes precedence)

References**Limiting references**

This place does not cover:

Safety edges for power-operated mechanisms for wings using detection by means of monitoring fluid pressure	E05F 15/47
--	----------------------------

E05F 15/603

using rotary electromotors

References**Informative references**

Attention is drawn to the following places, which may be of interest for search:

Detection of end position by striking, safety couplings	E05F 15/41
---	----------------------------

E05F 15/627

operated by flexible elongated pulling elements, e.g. belts, chains or cables (using flexible elongated push-pull mechanisms [E05F 15/619](#))

References

Limiting references

This place does not cover:

Using rotary electromotors to swing wings by push-pull mechanisms using flexible or rigid rack-and-pinion arrangements	E05F 15/619
--	-----------------------------

Informative references

Attention is drawn to the following places, which may be of interest for search:

Members cooperating with flexible elongated pulling elements	E05Y 2201/658
--	-------------------------------

Special rules of classification

[E05F 15/627](#) and [E05F 15/643](#) provide classification entries for swinging wings or horizontally-sliding wings operated by flexible elongated pulling elements. The indexing codes under [E05Y 2201/644](#) are used to classify flexible elongated pulling elements for any use associated with wings. The indexing codes under [E05Y 2201/644](#) are however not applied when classification symbols in [E05F 15/627](#) and [E05F 15/643](#) or subgroups are being allocated for inventive information.

E05F 15/635

operated by push-pull mechanisms, e.g. flexible or rigid rack-and-pinion arrangements ([E05F 15/652](#) takes precedence)

References

Limiting references

This place does not cover:

Horizontally-sliding wings operated by swinging arms	E05F 15/649
Horizontally-sliding wings operated by screw mechanisms	E05F 15/652
Horizontally-sliding wings for railway-cars	E05F 15/655 , E05Y 2900/51

E05F 15/643

operated by flexible elongated pulling elements, e.g. belts, chains or cables (by flexible elongated push-pull mechanisms [E05F 15/635](#))

References

Limiting references

This place does not cover:

Horizontally-sliding wings for railway-cars	E05F 15/655 , E05Y 2900/51
---	---

E05F 15/649

operated by swinging arms

References**Limiting references***This place does not cover:*

Horizontally-sliding wings for railway-cars	E05F 15/655 , E05Y 2900/51
---	---

E05F 15/652

operated by screw-and-nut mechanisms

References**Limiting references***This place does not cover:*

Horizontally-sliding wings for railway-cars	E05F 15/655 , E05Y 2900/51
---	---

E05F 15/681

operated by flexible elongated pulling elements, e.g. belts

References**Limiting references***This place does not cover:*

Flexible rack-and-pinion arrangements	E05F 15/67
---------------------------------------	----------------------------

E05F 15/6899

{operated by rack bars and toothed wheels or other push-pull mechanisms}

Definition statement*This place covers:*

Operation by push-pull mechanisms, e.g. moving between terminal ends.

Illustrative example of the subject matter classified in this place:

Rack (10) with upper and lower terminal ends.

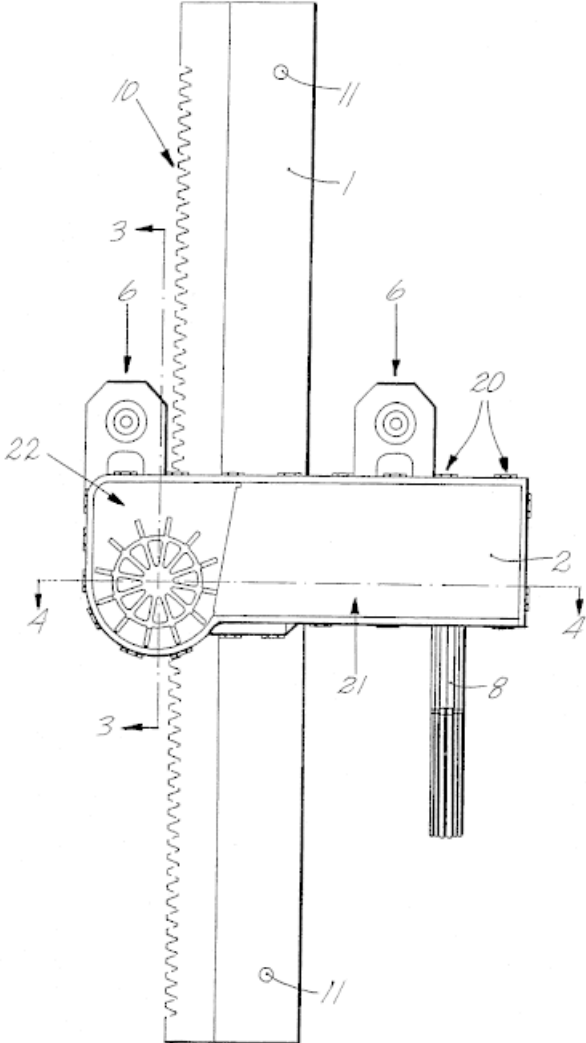

E05F 15/6901**{Flexible rack-and-pinion arrangements}****Definition statement***This place covers:*

Illustrative example of the subject matter classified in this place:

Flexible rack (4) with upper (49) and lower (43) terminal ends.

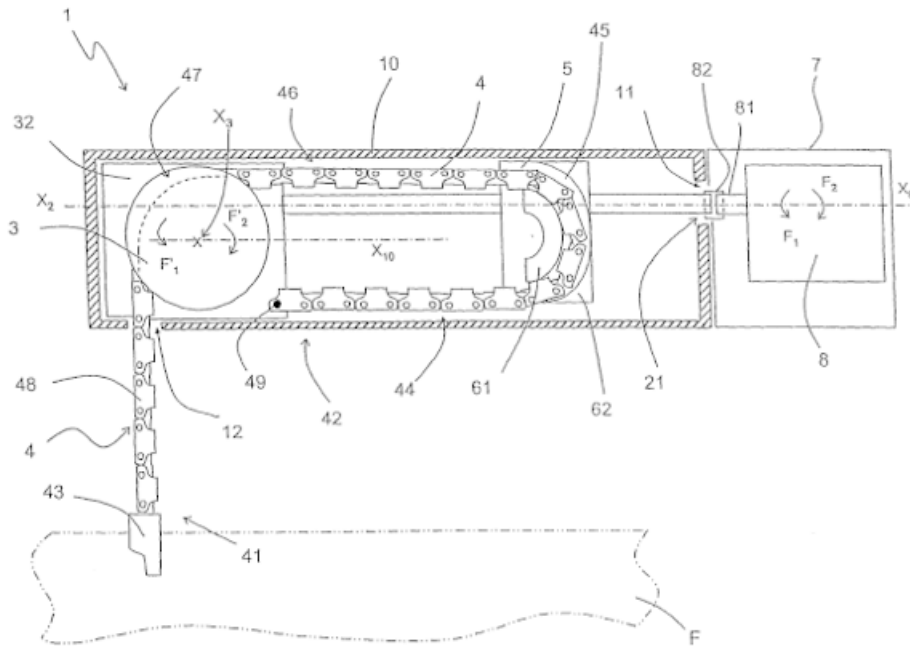
**E05F 15/6907****{operated by cords or chains or other flexible elongated pulling elements, e.g. tapes}****Definition statement***This place covers:*

Operation by flexible elongated pulling elements, e.g. endless loop arrangements.

Illustrative example of the subject matter classified in this place:

Flexible pulling element (84) forming a loop.

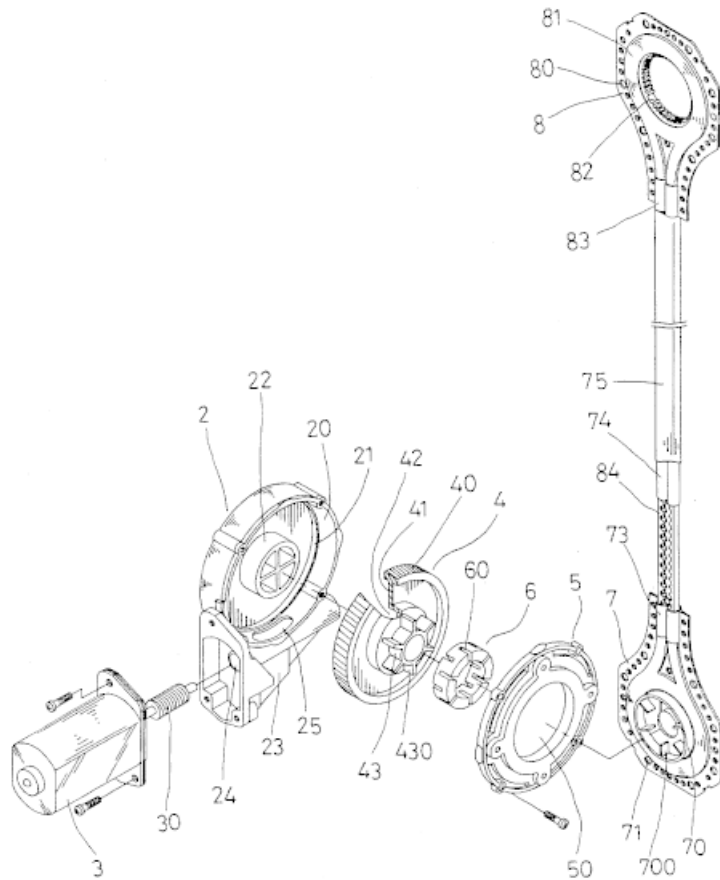

E05F 15/70

with automatic actuation

Definition statement

This place covers:

Operating mechanisms actuated, i.e. started or controlled after starting, by automatic means.

References

Informative references

Attention is drawn to the following places, which may be of interest for search:

Safety devices	E05F 15/40
----------------	----------------------------

Glossary of terms

In this place, the following terms or expressions are used with the meaning indicated:

Automatic	Independent of external or manual control, i.e. control by detection, sensing or measuring
-----------	--

E05F 15/71

responsive to temperature changes, rain, wind or noise

References**Informative references**

Attention is drawn to the following places, which may be of interest for search:

Responsive to emergency conditions, e.g. fire	E05F 15/72
Indexing code for physical protection against high or low temperatures	E05Y 2800/414

E05F 15/72

responsive to emergency conditions, e.g. fire

References**Informative references**

Attention is drawn to the following places, which may be of interest for search:

Operating or controlling mechanisms for physical fire-barriers	A62C 2/24
Locks actuating in response to heat	E05B 65/104
Indexing code for physical protection against fire	E05Y 2800/416
Indexing code for physical protection against smoke or gas	E05Y 2800/42

E05F 15/76

responsive to devices carried by persons or objects, e.g. magnets or reflectors
([E05F 15/77](#) takes precedence)

References**Limiting references**

This place does not cover:

Wireless control devices carried by persons or objects	E05F 15/77
--	----------------------------

E05F 15/77

using wireless control

Definition statement

This place covers:

Automatic wireless control of wings, e.g. programmable control transmitted wirelessly.

E05F 15/78

using light beams

Definition statement

This place covers:

Wireless control using light beams, e.g. infrared control.

E05F 17/00

Special devices for shifting a plurality of wings operated simultaneously (for simultaneously moving a plurality of interconnected ventilating lamellae [E06B 7/086](#))

Definition statement

This place covers:

Operating mechanisms for wings constructed to convert the force input from a user, motor, opener or closer into simultaneous movement of several wings.

References

Informative references

Attention is drawn to the following places, which may be of interest for search:

Simultaneously moving a plurality of interconnected ventilating lamellae	E06B 7/086
--	----------------------------